



MOVING COIL ACTUATORS FOR AUTOMATION

QUALITY CONTROL Sample Applications



"The ability to do work and verify its accuracy at the same time"

SMAC Actuator

The voice coil linear actuator is a robust high-precision manufacturing and measurement tool which is designed for long-life and durability. Users benefit from a high speed, repeatable tool with no backlash.

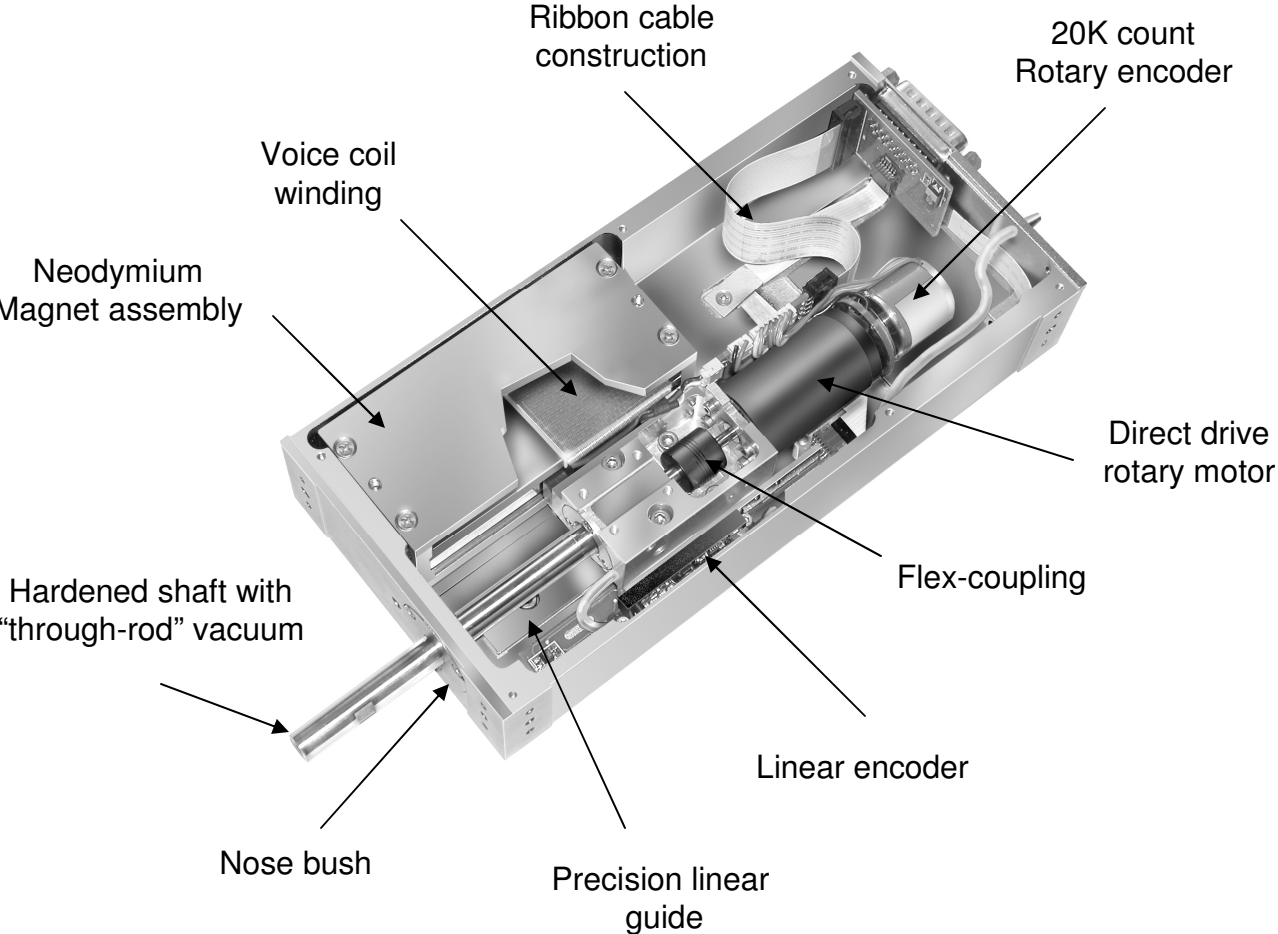

SMAC Technology

MOVING COIL

At the heart of all SMAC actuators is the moving coil.

The principle is broadly the same as you will find in any permanent magnet loudspeaker.

The voice coil sits in a strong magnetic field, and by passing a current through the coil a force is generated in either direction. The coil is wound on an aluminium bobbin for strength and dimensional control.

The Current is relatively low compared to other linear motor manufactures. SMAC uses approximately 2 amp max as opposed to 6-10 amps used by others. The Coil runs cool and therefore at a high duty cycle.

MOVING COIL TECHNOLOGY

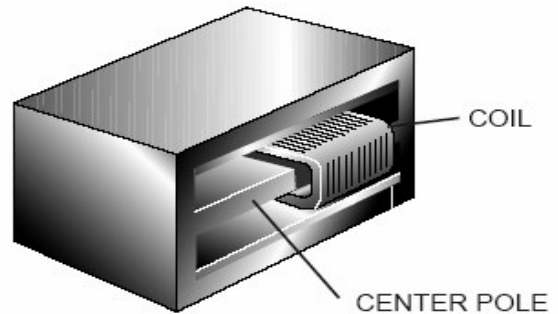
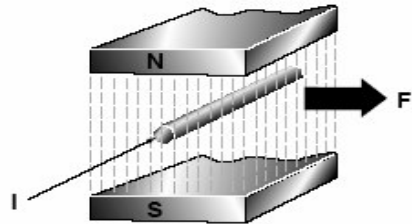

The force generated is proportional to $N I B$ where:
 N is the number of turns in the winding,
 I is the current flowing through the winding and
 B is the magnetic flux.

Force \propto Current

Therefore, by controlling current we can accurately control the force output.

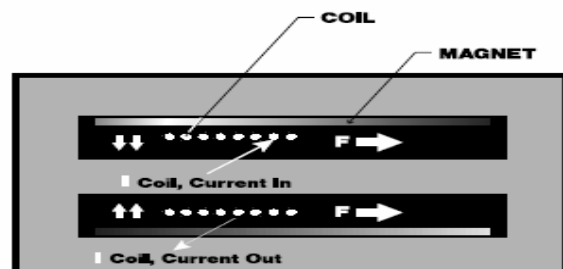

Current (I) circulates in coil
Crosses flux lines (B)
Develops Force (F)

$$F = n I B$$

SMAC Advantages

SOFT LANDING (patented)

- Ability to “soft land” onto delicate parts to avoid damage
- Programmable motion profile
- MULTI-AXIS
- XYZ Theta

REPEATABILITY

- Accurate repeatable positioning to +/- 3 encoder counts
- High speed, long life design for continuous operation
- Force feedback

PROGRAMMABILITY

- Easily programmed position and force “windows” to warn of missing or broken components.
- Programmable force/torque, position, velocity in all axes

DATA COLLECTION

- Data collection of all measurements possible
- Part to part datum recognition on the fly

MULTI-FUNCTION

- Assembly and test functions in one unit.
- Life testing of components as well as measurement functions in one unit.

HIGH PRECISION

- Up to 5 nanometer resolution possible in some models

ISO17025

- ISO17025 certification available on certain models

COMPACT SIZE

ECONOMICAL

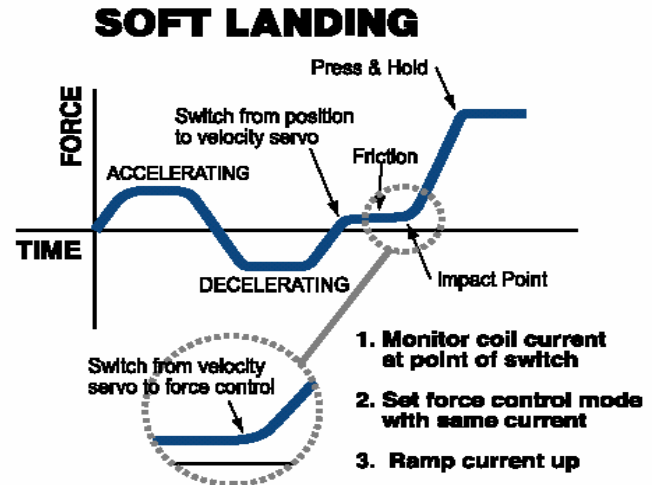

DATA COLLECTION

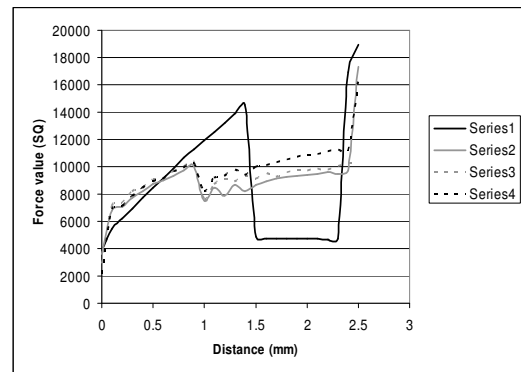

INDEX

• SMAC Actuator	2
• SMAC Technology	3
• SMAC Advantages	4
• Sample applications	
– Thread Check	6
• Thread Check Methodology	7
• Sample Applications	8
– U-joint Impeller Casting	
– Oil pan	
– Fuel valve	
– Wheel bearing casting	
– Bore Gaging and Groove Inspection	9
• Methodology - Straight Bore	10
• Methodology - Tapered Bore	11
– Air bag base	12
– Fuel Injector Plug	13
– Automobile engine	13
– Gaging	
• Internal and External Diameter Gaging	14
• Height Gaging - Fuel Discs	15
• Thickness Gaging	16
• Multiple Gaging - Wheel bearing	17
– Human Interface Testing	18
• Switches, Buttons, Keyboards	19
• Latches	20
– Contact Inspection	
• Tube bend inspection test	21
• Soft Contact Lens Mold	22
• Rod eccentricity inspection	23
• TV tube inspection	24
– Push/Pull Testing	
• Pull Test for Hypodermic Syringe Needles	25
– Materials Testing	
• With linear actuator	26
• With grippers	27
• Material Testing Impact Simulation	28

Thread Check

- Check for **double tapped thread**
- Check for **NO THREADS**
- Check for **BROKEN TAP**
- Check for **SHALLOW TAPPED THREAD**
- Check for **CROSS THREADING**
- Check **PITCH / OVERSIZED THREAD**



Actuators: LAR-55

Stroke (mm): 50, 100
Resolution: 1 or 5 micron
Force: 10 newtons
Moving Mass: 210 gms
Rotary Axis: 0.072 degree resolution
Torque: 0.1 newton-meter
Supply Voltage: 24 Volts

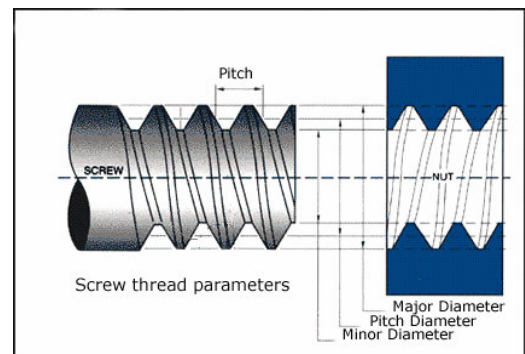

SMAC Advantages

- Torque used to rotate thread gage can be monitored
- Checks both the presence and condition of thread
- 100% test
- Z-Theta actuator in a single ready to mount package
- Integrated Linear/Rotary packages
- Totally programmable (Force, Position & Velocity)
- Soft land capability to find surface without damaging the thread gauge tip
- Micron and sub-micron accuracy & repeatability
- Ability to work in environments where vision and lasers do not function

Thread Check Methodology



Screw Thread Checking

A combined Linear/Rotary (Z-Theta) SMAC Actuator is used to carry a Go-Thread plug gage which engages and tests a tapped thread.

Key Operational Details

1. SMAC Actuator / gage finds the Z plane and thread lead (start of first thread) by counter clockwise rotation. A double threaded hole will also be determined.
2. Evaluates thread condition. High torque = one of the following: Undersize minor diameter, undersize pitch diameter, broken tap, incomplete thread depth
3. For through thread, gage shank is prepared with “step diameter”, to evaluate if thread minor diameter is oversized.
4. Unique to SMAC Actuator / gage is the “push – pull” measurement. While the gage is still engaged, the actuator pauses rotary motion, then push and pull linear. (See Figure A). The amount of linear movement is translated into thread clearance, eliminating the “no-go plug gage”. Once complete, rotary continues counter clockwise, then returns Z home.

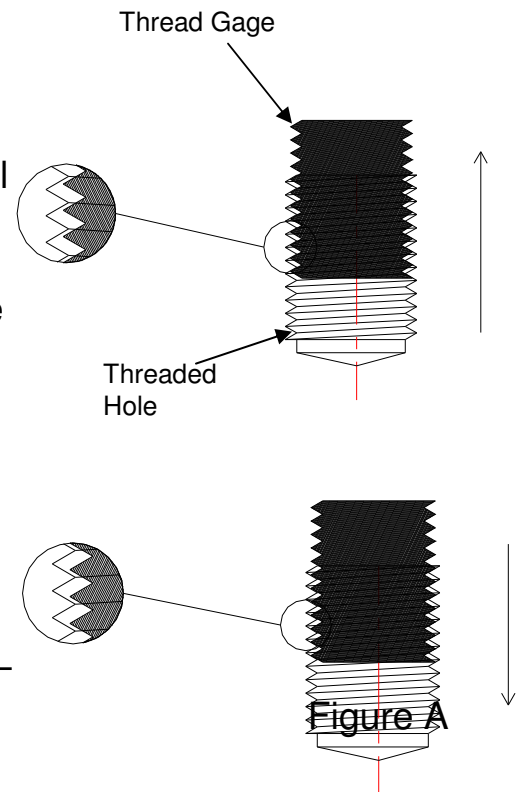

Thread Check Sample Applications

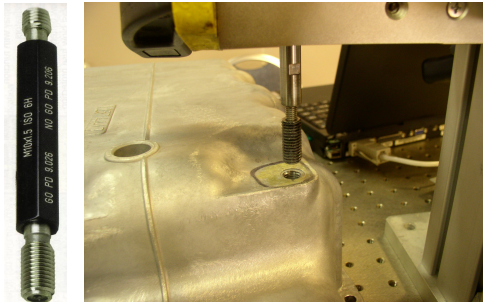

Oil pan

Thread was checked using a plug thread gage coupled directly to the end of the shaft of the SMAC actuator.

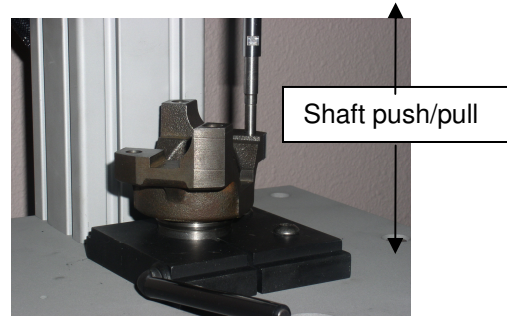

U-joint Impeller Casting



Wheel Bearing Casting

Checking For...

- Shallow Tap
- Undersize / oversize Thread
- Chamfer depth



Fuel Valve

Five SMAC LAR55's are used to check threads and adjust valve flow rate at the same time.

Other thread check applications

- Water pump casting
- Cam shaft
- Steering Housing Casting
- Axles and axle covers
- Fuel Injector Nozzle

Bore Gage & Groove Inspection

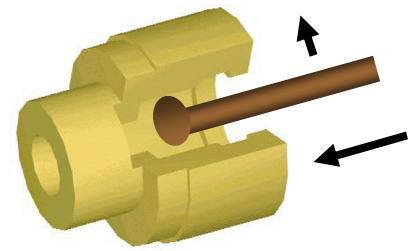

Key Operational Details

- 100% in-process inspection
- Seven internal features inspected
- XY configuration with LXY25-25 allows inspection of internal dimensions
- Each axis is driven by an independent linear motor
- Each axis is independently programmable in position and force
- The contoured probe performs a soft-land to engage the inside wall without damaging or deforming the surface

SMAC Advantages

- Delicate touch means that contact surfaces can still be measured even if they have different shapes, texture or compressibility
- 9 measurement points taken in ≈ 2 seconds
- Data Acquisition capability
- Softland prevents damage
- Controlled force ensures measurement
- Repeatability

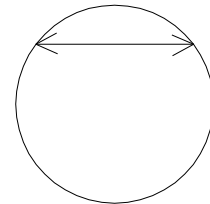

Figure A

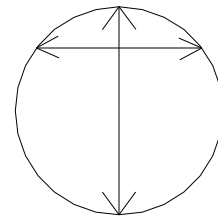

Figure B

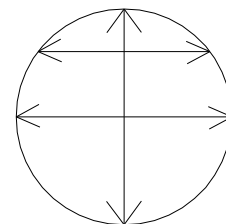
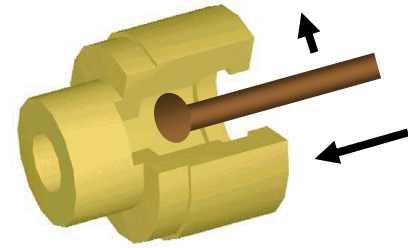

Figure C

Bore Gage & Groove Inspection



Methodology - Straight Bore

1. Soft land inside bore anywhere using X axes, record linear counts.
2. Move X axes to side opposite, soft land, record counts.
3. Divide total counts by 2 to find the center of bore.
4. Move X axes to center of bore. (See Figure A)
5. Soft land Y axes, record linear counts.
6. Soft land Y axes side opposite, record linear counts.
7. Divide total counts by 2 to find center of bore. (See Figure B)
8. Soft land X axes again (Y on center) both sides of bore for accurate measurement. (See Figure C)

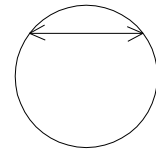

Figure A

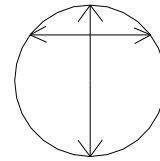

Figure B

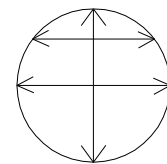
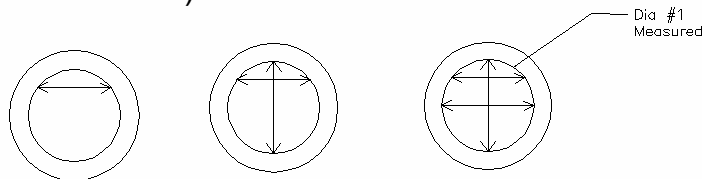

Figure C

Bore Gage & Groove Inspection Methodology - Tapered bore

Two bore measurements are needed to calculate tapered bores.

Utilizing XY bore measurement methodology, measure diameter #1 (or small end of bore).



Then use 90° right triangle trigonometry to calculate taper angle.

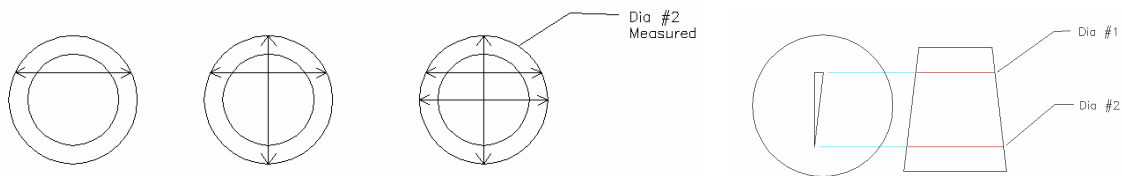

Diameter #2 - Diameter #1 = x.

$$x/2 = b$$

Z depth distance from Diameter #1 to Diameter #2 = c

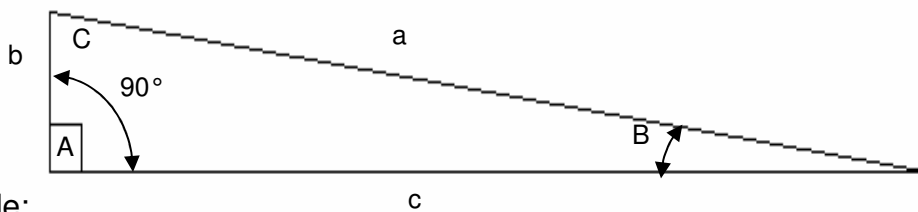

Example:

To determine Angle B,

D1 = 10mm, D2 = 15mm, Z depth = 12 mm (c)

$$(D2 - D1)/2 = 5/2 = 2.5 (b)$$

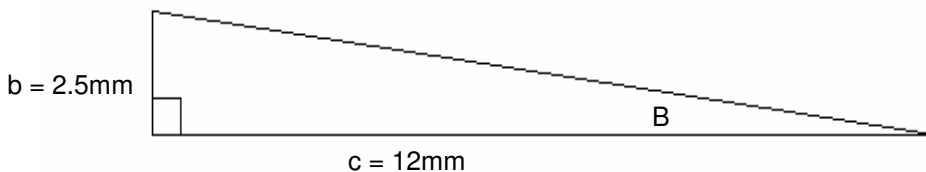

Tan B = b/c, Tan B = 0.20833, Therefore B = 11.46 degrees (using trigonometric logarithm chart)

Included angle or total angle of taper is:

Angle (B) x 2, or (11° 46') x 2 = 23°32',

Therefore, the Total Taper in this example = 23°32'.

Bore Gage & Groove Inspection Airbag Base



- 100% in-process inspection of air bag bases, which are a safety-critical component
- 2 external features and 7 internal features inspected
- Using LAS95-15 & LAL35-50 to create an X-Y and Plug Gage
- 1.2 second cycle time
- 24/7 operation
- Data Acquisition capability
- Soft-land prevents damage
- Controlled force ensures measurement repeatability
- Checking automatically:
 - Bore diameter
 - Bore depth
 - Undercut

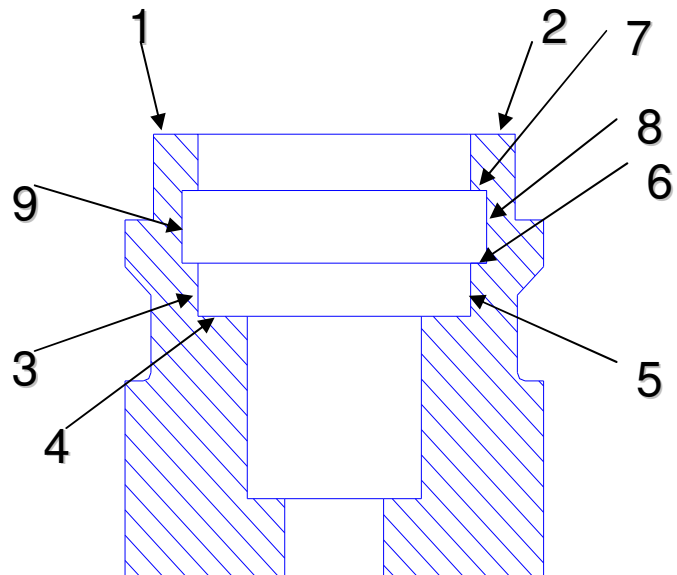

CHARACTERISTIC MEASUREMENT POINTS

FLATNESS	1 TO 2
BORE DEPTH	1 TO 4
BORE DIAMETER	3 TO 5
SWEEP & LOCATE GROOVE	5 TO 6
GROOVE LOCATION	5 TO 6
GROOVE WIDTH	6 TO 7
GROOVE DIAMETER	8 TO 9

Bore Gage & Groove Inspection

Other Sample Applications

Fuel Injector Plug

- The bore inside a fuel injector assembled part is gauged with a plug gage on the end of the LAL20-25 (*With a max of 100 grams force*) to detect if the hole is undersized (crushed or dented in) with out marking the part during the plug gage process. The bore is in a deep drawn metal part inside of a plastic injection molded body, and sometimes the bore is crushed when the injection molding is done.
- Some of the current systems of LVDT's/ Load cells and air cylinders were leaving marks on the part, which caused them to be rejected by the end customer (a major automobile manufacturer).

Automobile Engine

- Since the inside of an automotive engine is finely uneven, it is difficult to measure. Fingers of GRP17 are infused with resin, and pear fingers off after resin dry. Then pick out GRP17 from gauge and position it again, and measure with laser measure equipment.

Internal & External Diameter Gaging (using grippers)

Gripper with Independent Fingers

- Maximum Opening: 30 mm
- Resolution: 1, 5 micron
- Force (newton): 25
- Payload (gm): 100
- Weight (kg): 0.75
- Operating Voltage: 24 Volts

Key Operational Details:

- Each finger is driven by an independent linear actuator
- Each finger is programmable in position and force
- Each finger performs a soft landing profile to engage the inside wall surface

SMAC Advantages:

- Independently operated fingers means that parts need not be precisely centered
- Delicate touch and feel means that contact surfaces can be different shapes, texture or compressibility
- Part can be measured for type of material, size, orientation

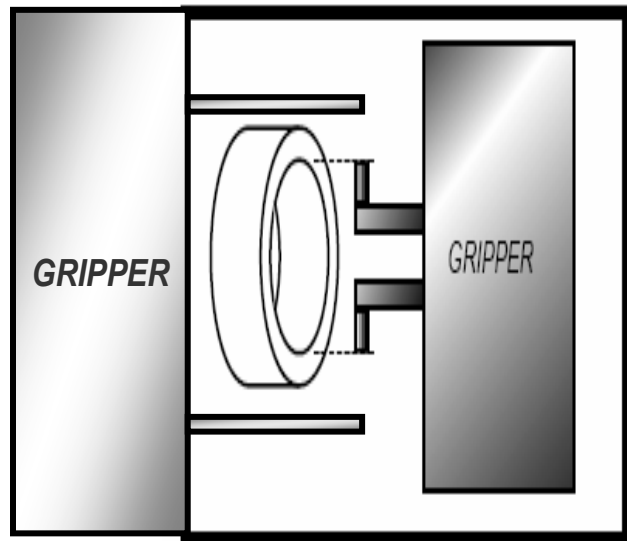

SMAC Gripper featuring 2 independent axis of "finger" control

Height Gaging

Measure each part against go-no-go window. Measure each part and store part height data (transmit to PC). Measure each part, sort into good/bad parts

Actuator: LAL-35

- Stroke (mm): 50/100
- Resolution: 1 or 5 micron
- Force: 10/7 newtons
- Moving Mass: 0.095 Kg
- Supply Voltage: 24 Volts

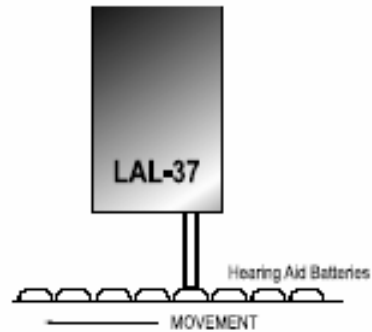

Key Operational Details:

High speed approach, slow down, softland on part, part is measured
 Measurement is compared against GO/NO GO window Good/Bad part
 signal is turned on

SMAC Advantages:

- 100% parts inspection
- Linear actuator in a single ready to mount package
- High speed, long life design for continuous operation
- Programmable profile to handle delicate parts
- Rod run out -- less than 20 micron to achieve good alignment

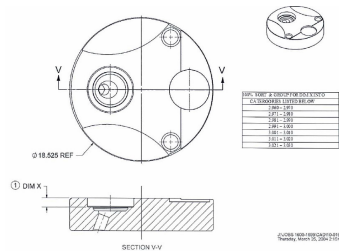

**Sample Height Gaging Application
 Fuel Disc**

Height gauge of a counter bore step inside the part. Sorting parts to under 1uM tolerance, using the 0.1uM encoder

Thickness Gaging

Replaces Micrometers and Calipers

Gripper with independent Fingers

Maximum Opening: 30 mm

Resolution: 1, 5 micron

Force (newton): 25

Payload (gm): 100

Weight (kg): 0.75

Operating Voltage: 24 Volts

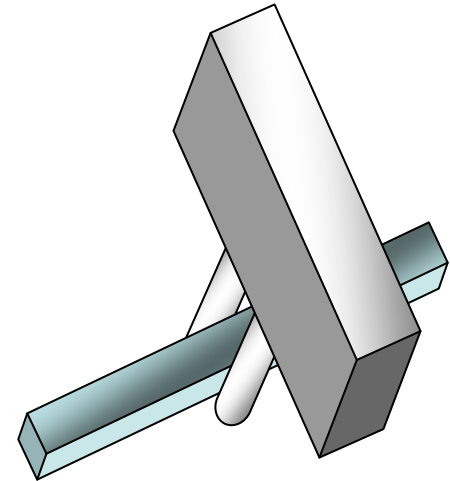

Key Operational Details:

- Each finger is driven by an independent linear actuator
- Each finger is programmable in position and force
- Each finger performs a soft landing profile to engage the inside wall surface

SMAC Advantages:

- Independently operated fingers means that parts need not be precisely centered
- Delicate touch and feel means that contact surfaces can be different shapes, texture or compressibility
- Part can be measured for type of material, size, orientation



Human Interface Testing

SMAC actuators are used for checking:

- Stroke, to make/ to break contact
- Force, to actuate switch
- Spring constant
- Life time cycling

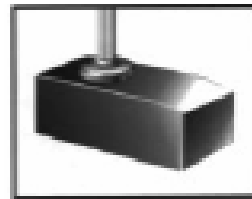
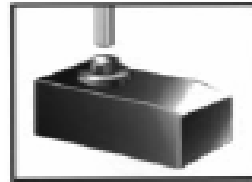

SMAC Advantages:

- High speed, long life design for continuous operation
- Z-theta actuator in a single ready to mount package
- Ability to “soft land” onto delicate and low-force micro-switches with a force of only a few grams
- Force feedback allows the user to measure break/toggle point on out and return stroke, thus displaying switch differential hysteresis effect.
- Easily programmed position and force “windows” to warn of missing or broken components.
- Life testing of components as well as measurement and QA reporting functions in one unit.
- Assembly and test functions in one unit.
- Data capture to plot force vs position

- Switch Testing: Hysteresis Effect

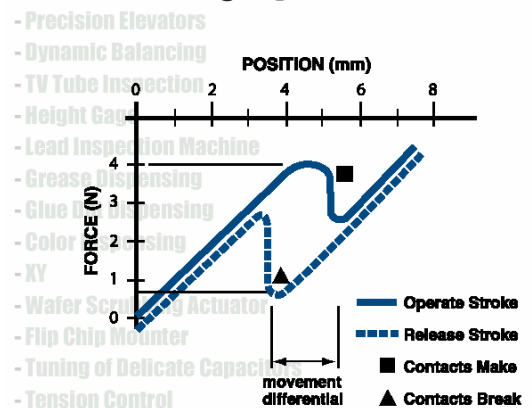

Data Capture

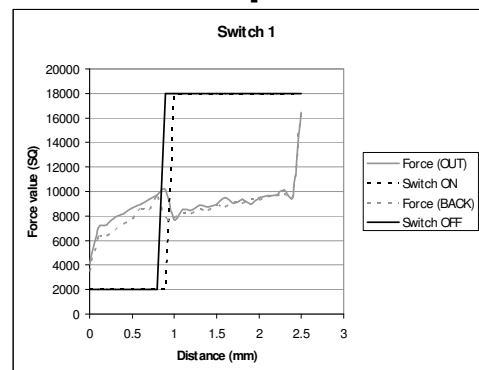

Human Interface Test Sample Applications

Buttons

- Cell phone keypads
- PC keyboards
- Membrane keypads
- Valves, sensors and relays
- ATM keypads
- Seat belt buttons
- Piano keyboard



Switches

- Light switches
- Automobile switches
- Audio switches
- Cruise control switches
- Car Navigation systems
- Trunk release switches
- Kitchen appliances
- Car horn switches

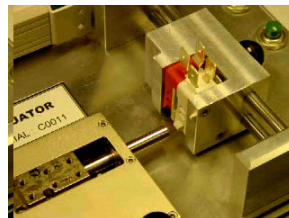

Touch Screens

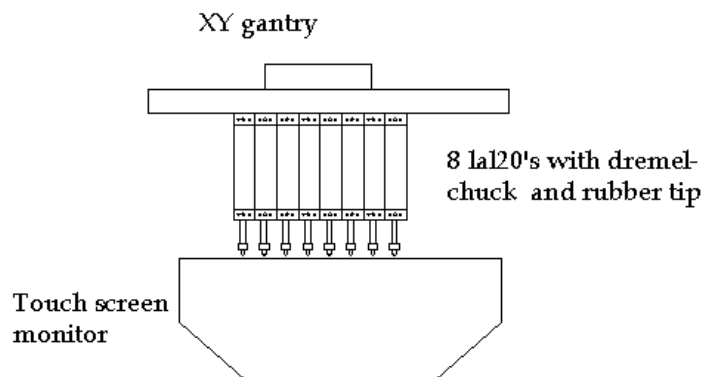

Human Interface Testing

Latch Inspection

Force used to compress the spring to close the latch is checked using an SMAC **LAL-90** actuator

Actuator: LAL-95

Stroke (mm): 15, 50

Resolution: 1 or 5 micron

Force: 100 newtons

Moving Mass: 250 gms

Supply Voltage: 48 Volts

Key Operational Details:

- High speed approach, slow down, softland
- on part, part is measured to check for correct
- location
- Force is increased in steps, position and
- force measured to determine proper latch
- Operation



SMAC Advantages:

- Force can be selected in position servo mode
- Position can be measured to 1 micron resolution.
- In force mode, parts can be precisely
- measured with a reproducible contact force
- Force can be measured with a resolution of 20 grams
- Measurements can be transferred to a host computer to make the calculations

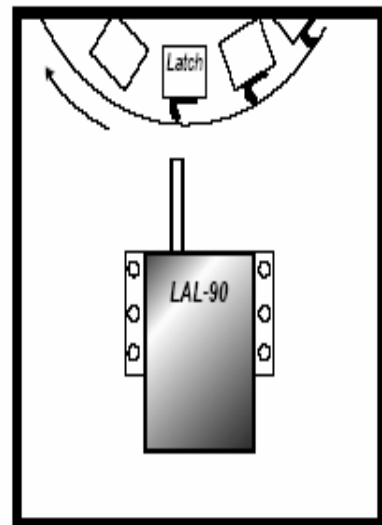

Contact Inspection Tube Bend Test

- Verifying that angles are within tolerance
- Soft-land protects damage to the end of the tube and the installed o-ring.

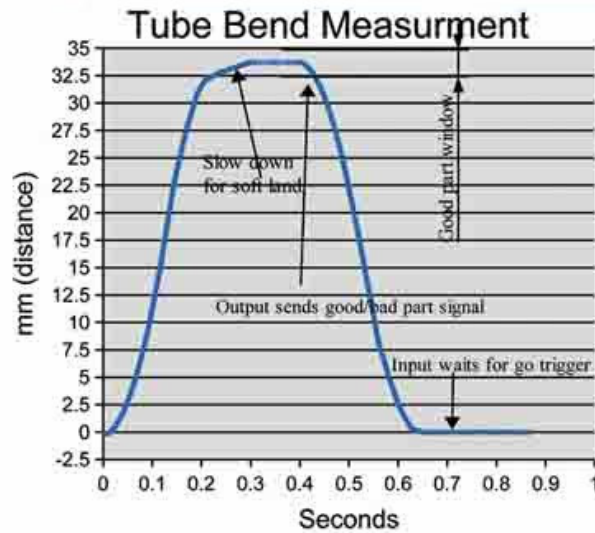
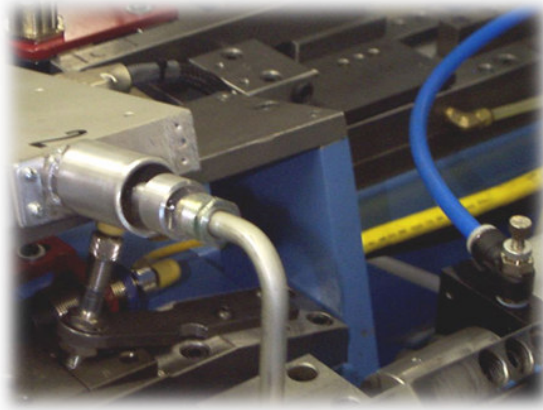

Contact Inspection

Soft Contact Lens Mold

Actuator: LAL-35

Stroke (mm): 50/100

Resolution: 1 or 5 micron

Force: 10/7 newtons

Moving Mass: 0.095 Kg

Supply Voltage: 24 Volts

Key Operational Details:

- Bottom actuator lifts up, softlands
- (30grams) on measuring tip
- Top actuator extends, softlands on
- contact lens mold
- Measurement is taken
- Good/Bad part signal is turned on

SMAC Advantages:

- 100% parts inspection
- Linear actuator in a single ready to
- mount package
- Reproducible force setting to get
- consistent measurement

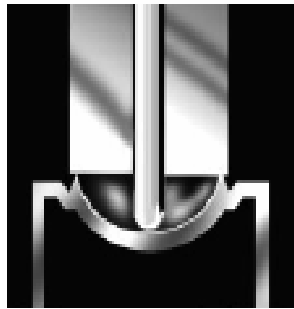
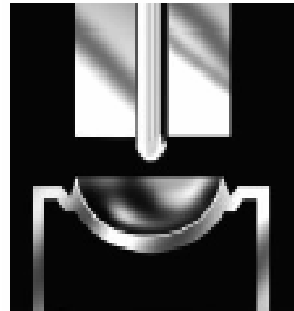

Each prescription for a soft contact lens is embodied in a single plastic mold. The mold costs less than one dollar but by the time a lens is made, several dollars may have been expended. It is prudent to check the mold for the correct measurement before it is used to make a lens.

The critical dimension is the distance from plane of the parting line to the spherical surface of the lens. Since the parting line is very sharp and the mold material is quite soft, it is necessary to make that measurement with a controlled light touch.

Solution

SMAC linear actuators can measure with a resolution of 1 micron and the force used can be set.

Work Profile

1. The SMAC actuator is equipped with a tip which is the same diameter as the parting line plane. The actuator rod can be driven through a hole in the center of the tip.
2. A second actuator with a spherical seat on its tip is used to contain and raise the mold up against the tip of the first actuator. The force used to seat the mold against the tip can be set at 30 gms.
3. With the mold in place, the rod from the first actuator is driven towards the spherical surface of the mold and soft lands on the mold. A measurement is made.

Contact Inspection Rod Eccentricity

Automotive rod is machined, heat-treated and inspected for eccentricity of four diameters. Four SMAC actuators are used. The rod is rotated. Each actuator measures the maximum / minimum travel and compares with the go-no-go values stored. An accept / reject indicator is turned on for the operator.

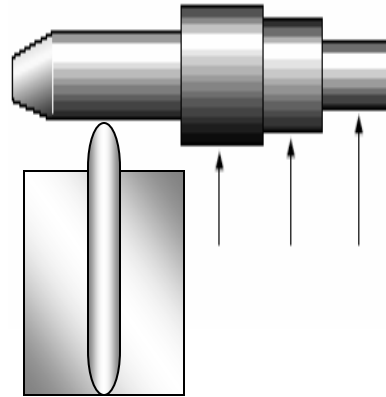

Key Operational Details

- High speed approach, slow down, soft land on rod surface
- Set force to 100g, monitor position as rod is rotated
- Register minimum & maximum positions and calculate eccentricity
- Measurement is compared against GO / NO-GO window
- Pass / Fail part signal is triggered

SMAC Advantages

- 100% inspection
- Programmable force profile
- High speed, long life design for continuous operation
- QA reporting function

Actuator: LAL-30 (low friction version)

Stroke (mm): 15, 25
Resolution: 1 or 5 micron
Force: 15 newtons
Moving Mass: 150 gms
Supply Voltage: 24 Volts

Key Operational Details:

High speed approach, slow down, engage rod

Set force to 100 grams, check position as rod is rotated

Register maximum & minimum readings and calculate eccentricity

Measurement is compared against GO/NOGO window

Good/Bad part signal is turned on

SMAC Advantages:

100% parts inspection

Linear actuator in a single ready to mount package

High speed, long life design for continuous operation

Programmable profile to set force

Contact Inspection

TV Tube Inspection

TV tubes are measured in gauging fixture using SMAC actuators which make the measurements and report the results to a central manufacturing computer.

SMAC Advantages:

- Force can be selected in position servo mode
- Position can be measured to 1 micron resolution.
- In force mode, parts can be precisely measured with a reproducible contact force
- Measurements can be transferred to a host computer to make the calculations

Other contact Inspection

Applications:

- Turbine blade
- Fuel injector tips

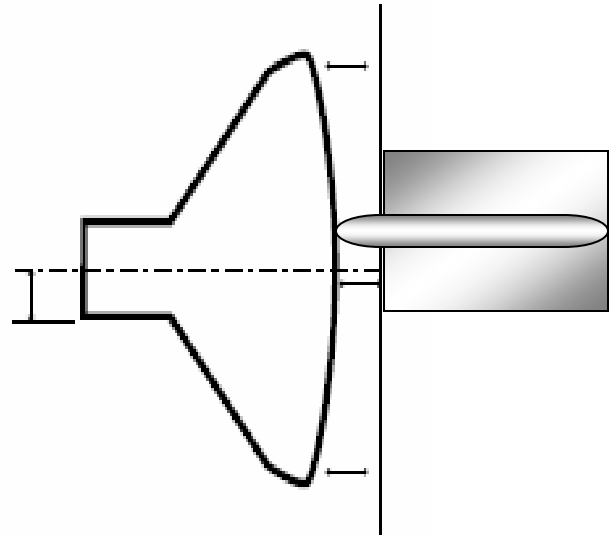

Push/Pull Testing

Hypodermic Syringe Needles

Hypodermic needles are 100% tested to make sure that the needles are secured to the hub.

The force is 4 lbs.

The rate is one per second.

The needles are assembled on a rotary index table.

When the needle comes into the station, a gripper grips the needle. A 4 lb force is applied to the needle and a position measurement is made. If the needle separates, a bad part is indicated.

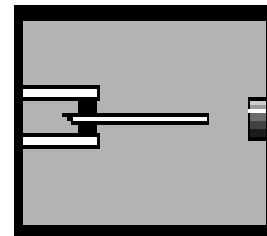
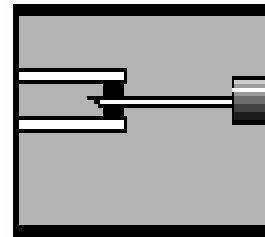

Actuator: LAL-95

Stroke (mm): 15, 50

Resolution: 1 or 5 micron

Force: 100 newtons

Moving Mass: 250 gms

Supply Voltage: 48 Volts

Key Operational Details:

- Position is registered with the gripper
- affixed to the needle
- Force is ramped up and position is monitored
- to check for any movement
- If needle separates, indicate good/bad part
- Force can be controlled to +/- 25 grams
- Position can be maintained to +/- 5 encoder
- counts

SMAC Advantages:

- Instantaneous transition from position mode
- to force mode
- Ability to monitor position in force mode
- and make decision to change programs

Material Testing with Linear Actuator

SMAC actuators can apply a known force while registering a position. This feature can be used to test:

Tensile and compression test

- Materials Testing
- Shear
- Accelerated Life testing

Biomaterials Mechanical Test

- LAL90-015 with 0.5m linear encoder and LAC-1 single-axis controller are used to apply tensile pressure



Filament Test

- LAR300-050-71 and LAC-25 & Cable are used to apply repetitive tensile force and rotary torque on a metallic filament for lifetime testing

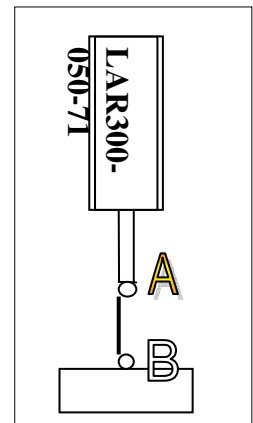
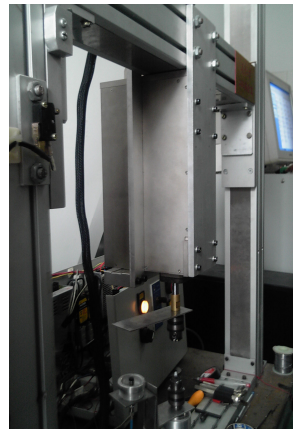

Suture Strength Test

- LAL-95-015-75-F equipped with a low friction linear slide and LAC-25 dual axis controller, LAH-RTD-03 cable are used to apply Pressure is applied to medical suturing material for pull inspection.

Material Testing with Grippers

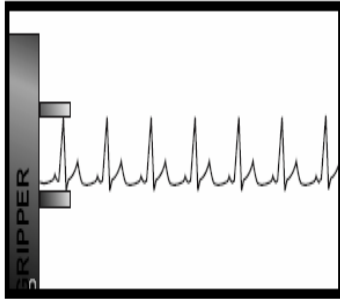

Material Lifetime Testing

A medical device manufacturer needs to test a heart valve material for long term fatigue. They wish to duplicate the heart beat profile to simulate actual conditions. SMAC actuators can be programmed to develop the heart beat motion profile. By measuring the force used to stretch the material to the prescribed length, the gradual degradation of the material can be continuously monitored.

Other Applications:

- Creep test for material under temperature & time
- Human motion simulation for Carpal tunnel check

Actuator: GRP-35 Gripper

Gripper with Independent Fingers
Maximum Opening: 30 mm
Resolution: 1, 5 micron
Force (newton): 25
Payload (gm): 500
Weight (kg): 0.75
Operating Voltage: 24 Volts

Key Operational Details:

- Each finger is driven by an independent linear actuator
- Each finger is programmable in position and force

SMAC Advantages:

- Independently operated fingers means that parts need not be precisely centered
- Complicated motion profile can be generated to accurately simulated heart beat
- Force can be monitored, so as material degrades, the resulting change in force as the material is exercised can be used to indicate a failure mode without stopping the test

Material Testing Impact Simulation

Impact damage on different skin materials is investigated using different forces and end tip diameters

Other Applications:

Force to drive surgical needle into a fixed distance is measured

Force to secure cork in test tubes



Actuator: LAL-95

Stroke (mm): 15, 50

Resolution: 1 or 5 micron

Force: 100 newtons

Moving Mass: 250 gms

Supply Voltage: 48 Volts

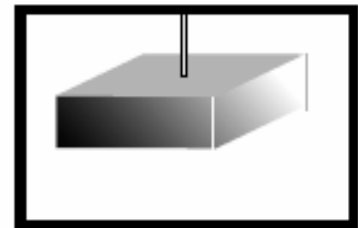

Key Operational Details:

- Force can be controlled to +/- 25 grams
- Position can be maintained to +/- 5 encoder
- Counts

SMAC Advantages:

- Instantaneous transition from position mode
- to force mode
- Ability to monitor position in force mode
- and make decision to change programs

