

Instrument Class®

Industrial Electronics

For Signal Conditioning
Data Acquisition
and Data Communications



 **DATAFORTH®**



The Company

“Our passion at Dataforth Corporation is designing, manufacturing, and marketing the best possible signal conditioning, data acquisition, and data communication products. Our mission is to set new standards of product quality, performance, and customer service.” **Dataforth Corporation**, with over 24 years’ experience, is the worldwide leader in Instrument Class® Industrial Electronics – rugged, high-performance signal conditioning, data acquisition, and data communication products that play a vital role in maintaining the integrity of industrial automation, data acquisition, and quality assurance systems. Our products directly connect to most industrial sensors and protect valuable measurement and control signals and equipment from the dangerous and degrading effects of noise, transient power surges, internal ground loops, and other hazards present in industrial environments.

Global Service and Support

Dataforth spans the globe with more than 50 International Distributors and US Representative Companies. Our customers benefit from a team of over 130 sales people highly trained in the application of precision products for industrial markets. In addition, we have a team of application engineers in our Tucson factory ready to solve any in-depth application questions. Upon receipt of a quote or order, our Customer Service Department provides fast one-day delivery information turnaround. We maintain an ample inventory that allows small quantity orders to be shipped from stock.

Research and Development Team

A professional staff of engineering and marketing personnel identify and develop products to satisfy our customers’ most stringent requirements. Dataforth’s design department is composed of advanced degree engineers specializing in innovative analog and isolation circuit development, ensuring our customers of the highest performance products at the lowest price.

Automated Manufacturing and Test

Automated manufacturing techniques and machines are employed to produce our state-of-the-art SMT designs in optimum time and at minimum cost. All products are tested multiple times in automated test fixtures, and many undergo a 48-hour burn-in at elevated temperatures.

Quality Control

Dataforth operates under an ISO9001:2000 quality management system. Since our products are used in critical industrial data acquisition, control, and test and measurement applications, we strive to produce the highest quality, premier performance products available on the market. Zero defects and complete customer satisfaction are our goals. To further strengthen our commitment to quality, Dataforth secures certifications such as UL, CSA, Factory Mutual, ATEX, and CE.

www.dataforth.com

Utilizing the latest Web development technology, our Website presents visitors with an intuitive, informative layout that quickly leads them to their areas of interest. A parametric search engine efficiently locates products by model number or functional description, while an e-commerce section provides pricing information and order entry. Fully detailed product data sheets and application notes are available for download in PDF format. Visitors also can request literature, view new product release data, read our bi-monthly newsletters, get answers to technical questions, and quickly locate Distributors and Sales Representatives. For our International community, our home page is available in 15 languages.

The Future

We fully understand that our ongoing success depends on satisfying our customers’ requirements. Building upon our current position as marketplace leader, Dataforth continues to seek out the most cost-effective emerging technologies in design and manufacturing in order to provide the highest performance quality products at the lowest price. By intelligently observing and responding to constantly changing market forces, we ensure the continuation of our critical customer partnerships.



**Zero defects
and complete
customer
satisfaction are
our goals**



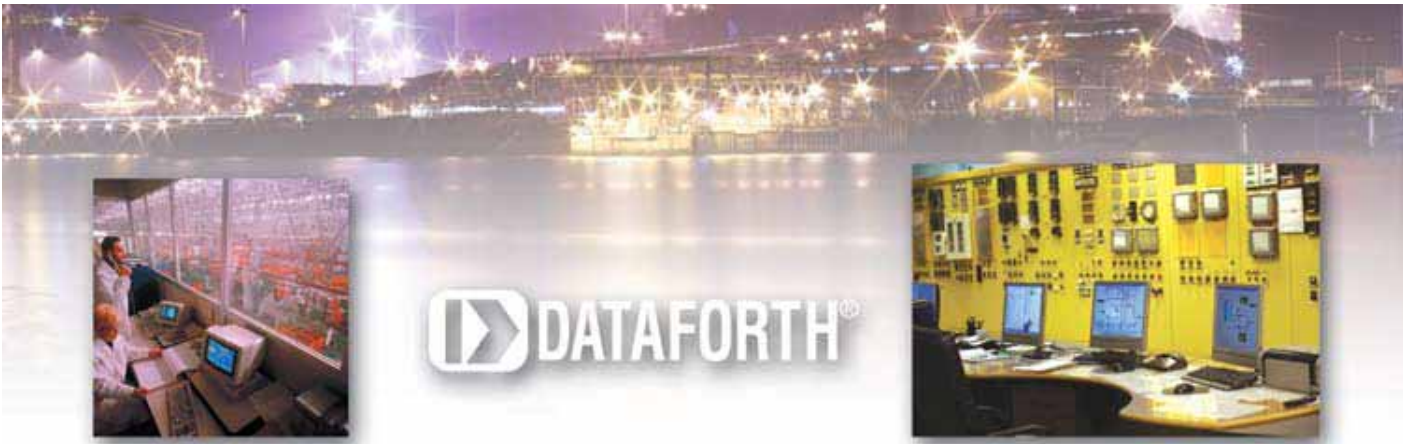

DATAFORTH®

Instrument Class® Field and Control Room Products for Data Acquisition, Analog and Digital Signal Conditioning, and Data Communications

Analog Signals—Thermocouple • RTD • Strain Gage • Volts • Milliamps **Digital Signals**—Contact Closures • Relays • Limit Switches • Indicator Lamps • Motor Starters

°C PSI mV mA GPM Freq °F AC BTU On Off

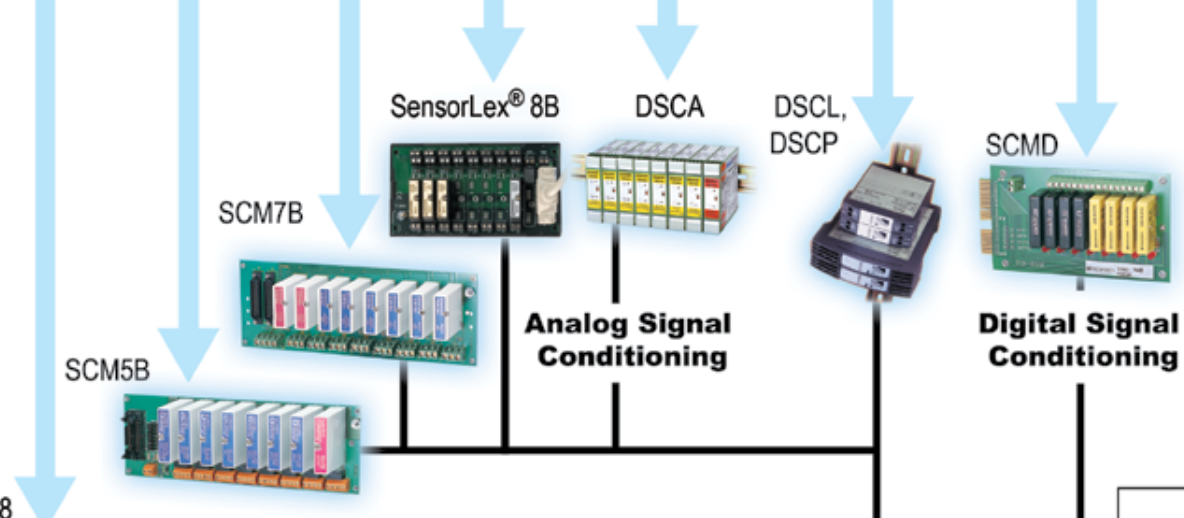

isoLynx®
SLX200/718



**isoLynx®
Data Acquisition System**



Control Room

A/D
TTL I/O
Serial I/O

RS-232

DCP485
RS-232/485
Converter

RS-485 Data up to 4000 Ft.

Digital Signal Conditioning

LDM30

LDM485

Twisted Pair,
4-20mA Loop

Protecting Valuable Industrial Signals and Data

Dataforth's dedication to ensuring the highest reliability and performance of customers' industrial automation systems is evidenced by the extensive range and unmatched versatility of our Instrument Class® signal conditioning, data acquisition, and data communication products. From broad-based families of isolated analog and digital signal conditioning modules to two-wire transmitters, a wide variety of data communication products, and the flexible, leading edge isoLynx® data acquisition systems, Dataforth products provide efficient, cost-effective protection for industrial signals and data in the control room, field, factory, and office.

Our customers invest significant amounts in their industrial automation operations; our commitment is to anticipate customer needs and respond with products that will enhance their operations' reliability, security, and productivity.

Dataforth Industrial Electronics

- **Analog-to-Analog Products**—Isolated DSCA, DSCL, SCM5B, SCM7B, and SensorLex® 8B I/O modules providing complete solutions for interfacing, conditioning, and distributing critical industrial signals.
- **Two-Wire Transmitters**—Rugged, low cost DSCT, DSCP, and SCTP transmitters linking remote "field" sensors to computers and control rooms.

- **Distributed Data Acquisition & Control Products**—Versatile isoLynx® SLX200 and SLX718 data acquisition systems and isolated, intelligent, programmable SCM9B I/O modules for flexible plant and laboratory applications.
- **Data Communication Products**—A wide selection of LDM limited distance data modems and converters, DIN rail mount DCP485 RS-232/RS-485 converters, and DCP35 RS-232 line drivers for secure, reliable data communication systems.

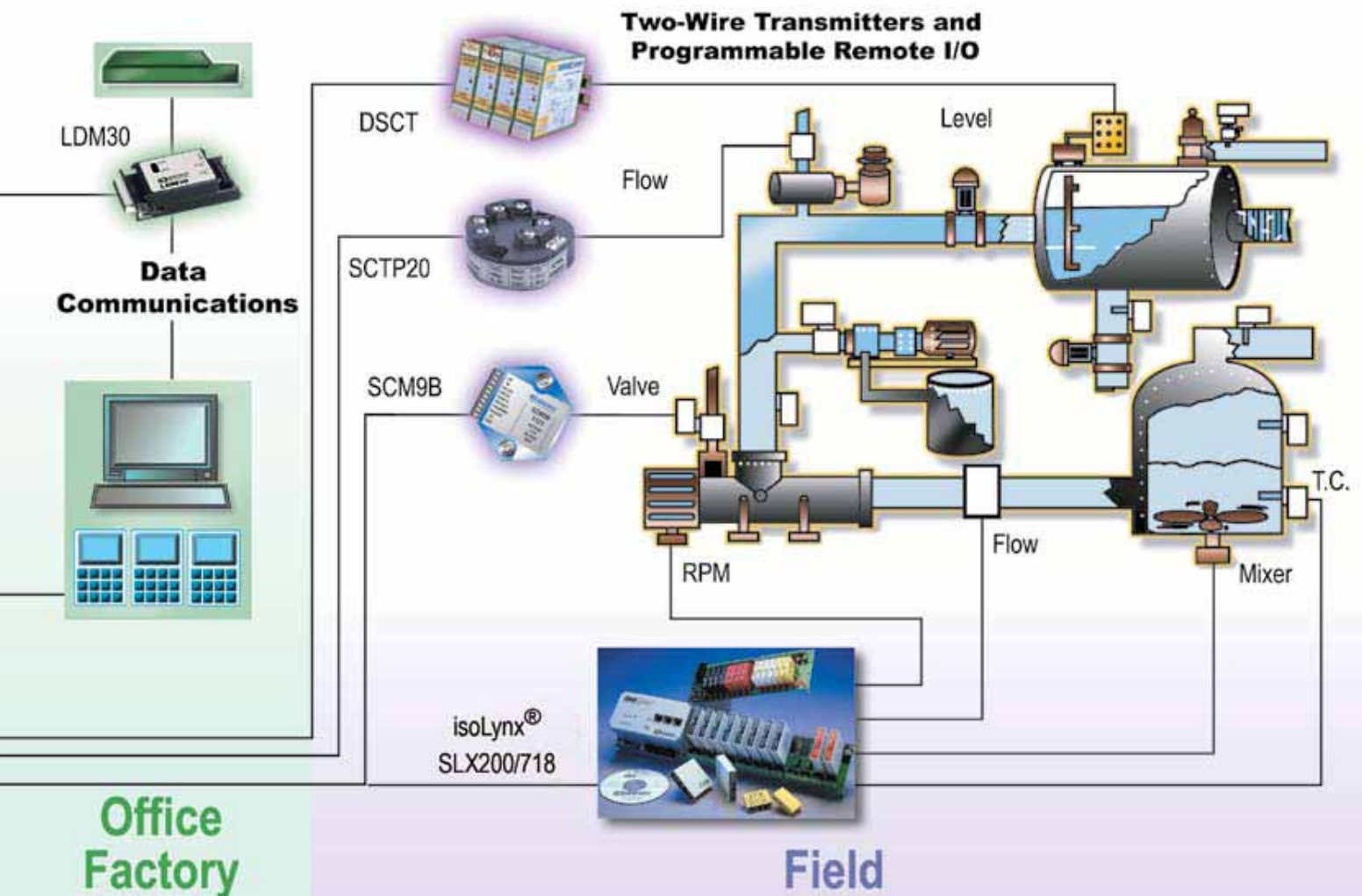

isoLynx® Data Acquisition Systems

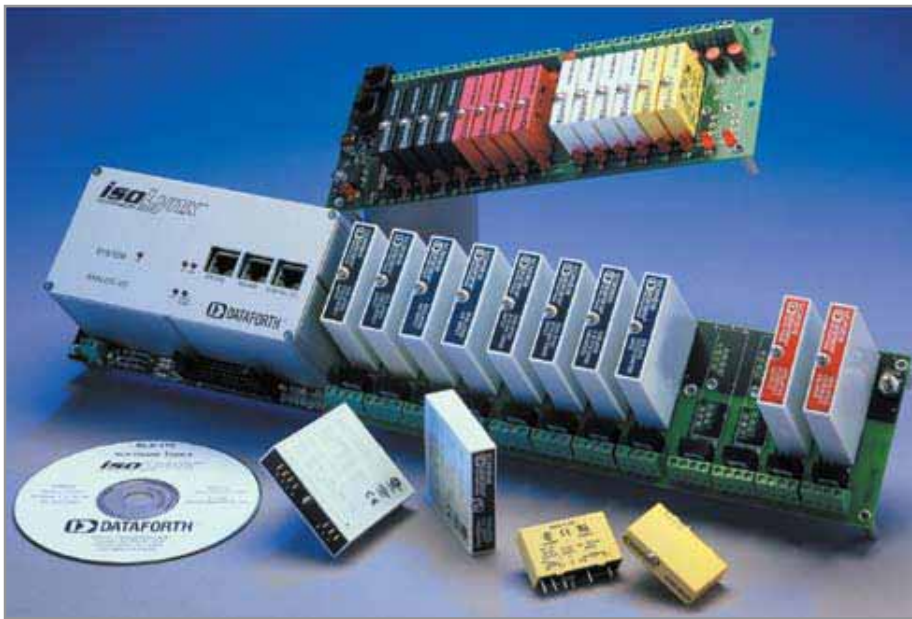

Faulty thousand-dollar data acquisition systems can shut down billion-dollar operations. Dataforth's isoLynx® SLX200 is a fast, intelligent, fully isolated data acquisition system providing superior reliability, accuracy, and isolation for a wide range of rugged industrial applications. It offers maximum flexibility of analog and digital I/O selection at competitive prices for a broad range of factory automation, process control, test and measurement, machine control, and data acquisition applications. The isoLynx® SLX200 implements the industry standard Modbus RTU and TCP protocols.

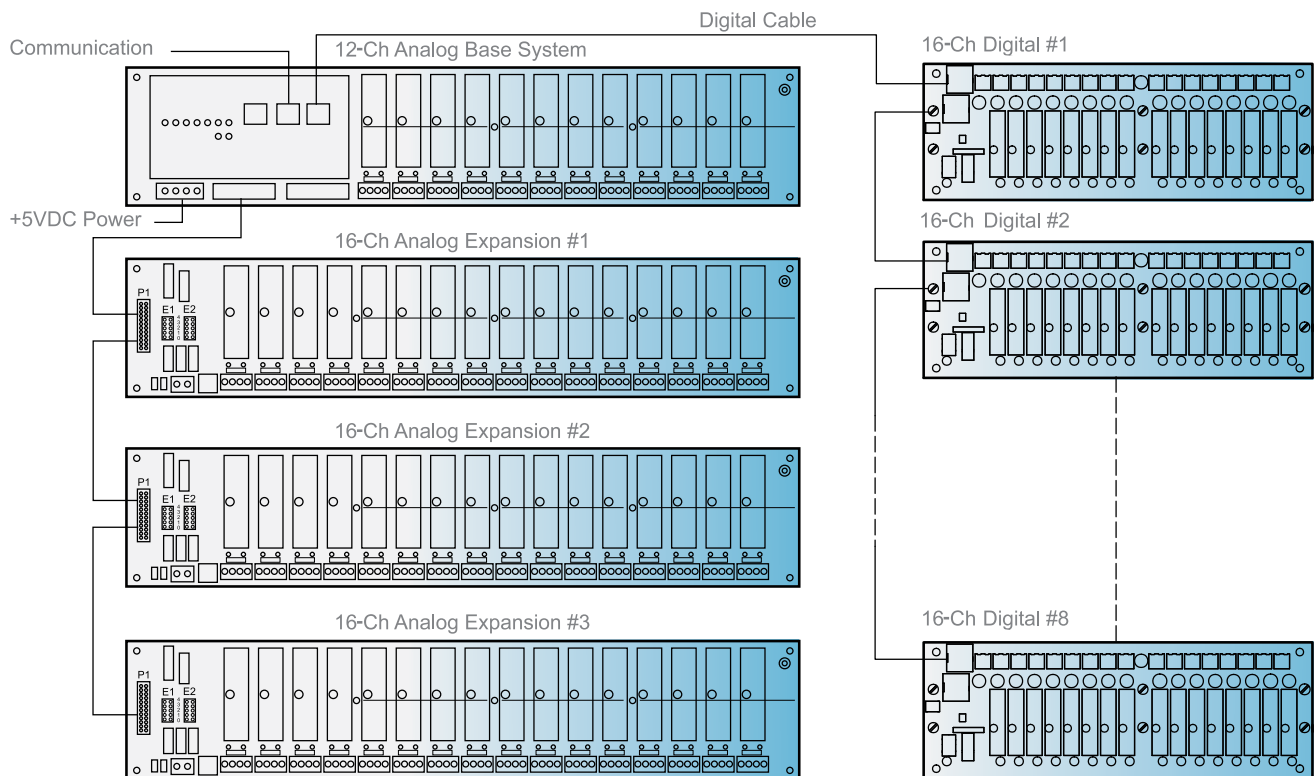

Figure 1

All I/O is channel-to-channel isolated

The flexible, modular design combines a 12-channel I/O Controller base system and optional 8- or 16-channel expansion back-planes, which can be either panel or DIN rail mounted (see Figure 1).

One I/O Controller module can operate up to 60 channels of differential analog I/O and 128 channels of digital I/O, using Dataforth's popular SCM5B analog and SCMD digital modules. The Controller contains a powerful high-speed microcontroller, A/D and D/A subsystem, communication interface, and

associated memory and status LEDs. The A/D system is built around a 16-bit, successive approximation converter and can convert a maximum 60-channel configuration in 15msec. The D/A converter is also a 16-bit device and can write a maximum 60-channel configuration in 30msec.

Model	Description
SLX200-10	12-Ch Base Unit, μ C and A/D Bds, RS-232/485
SLX200-20	12-Ch Base Unit, μ C and A/D Bds, RS-232/485 and Ethernet
SLX200-30	12-Ch Base Unit, μ C and A/D Bds, RS-232/485 and Dual Ethernet
SLX200-11	12-Ch Base Unit, μ C and A/D Bds, RS-232/485, No CJC
SLX200-21	12-Ch Base Unit, μ C and A/D Bds, RS-232/485 and Ethernet, No CJC
SLX200-31	12-Ch Base Unit, μ C and A/D Bds, RS-232/485 and Dual Ethernet, No CJC
SLX200-10D	12-Ch Base Unit, μ C and A/D Bds, RS-232/485, DIN
SLX200-20D	12-Ch Base Unit, μ C and A/D Bds, RS-232/485 and Ethernet, DIN
SLX200-30D	12-Ch Base Unit, μ C and A/D Bds, RS-232/485 and Dual Ethernet, DIN
SLX200-11D	12-Ch Base Unit, μ C and A/D Bds, RS-232/485, No CJC, DIN
SLX200-21D	12-Ch Base Unit, μ C and A/D Bds, RS-232/485 and Ethernet, No CJC, DIN
SLX20031D	12-Ch Base Unit, μ C and A/D Bds, RS-232/485 and Dual Ethernet, No CJC, DIN
SLX101	Backpanel Digital: 16 Ch
SLX101-D	Backpanel Digital: 16 Ch, DIN
SLX141-xx	Ethernet and Serial Cables
SLX270	Software Tools - VB, VC++, LabVIEW VI
SLX280	Quick Start, Software/Hardware User Manual Set

Model	Description
SCMPB02	Backpanel Analog: 16 Ch, Mux
SCMPB02-1	Backpanel Analog: 16 Ch, Mux, No CJC
SCMPB02-2	Backpanel Analog: 16 Ch, Mux, DIN Mount
SCMPB02-3	Backpanel Analog: 16 Ch, Mux, No CJC, DIN Mount
SCMPB06	Backpanel Analog: 8 Ch, Mux
SCMPB06-1	Backpanel Analog: 8 Ch, Mux, No CJC
SCMPB06-2	Backpanel Analog: 8 Ch, Mux, DIN Mount
SCMPB06-3	Backpanel Analog: 8 Ch, Mux, No CJC, DIN Mount
Analog I/O	Select from SCM5B Series Modules
Digital I/O	Select from SCMD Series Modules



Flexible, Powerful Programming and Communications

The **isoLynx**[®] communicates on RS-232/RS-485 serial links up to 115.2kbps and 10Mb/s Ethernet. Standard communication is RS-232/RS-485 and up to 32 systems can be multi-dropped on the RS-485 serial link.

The **isoLynx**[®] **SLX200** Application Programming Interface (API) defines a platform-independent, run-time function library used to program Dataforth's **isoLynx**[®] SLX200 hardware system under Windows XP/2000/NT/9X. As it implements the industry standard Modbus RTU and TCP protocols, the **isoLynx**[®] SLX200 enables communication with a wide variety of existing third-party software drivers and HMI/SCADA packages. It is fully certified by the Modbus-IDA organization and also is compatible with OPC.

The versatile **isoLynx**[®] **SLX718** data logger/data acquisition system is composed of compact SLX718 units and Dataforth's miniature **SensorLex**[®] 8B isolated analog signal conditioners. It offers stand-alone or PC-tethered data logging operation, combined with the unrivaled flexibility to change I/O on a per channel basis for each of eight signal conditioner locations.

Key Features and Specifications

- Modbus RTU Support on RS-232 and RS-485
- Modbus TCP Support (optional)
- 1500Vrms Channel-to-Channel, Channel-to-Bus Isolation & 240Vrms Field-Side Protection
- Fast 16-Bit A/D, D/A
- Best I/O Selection with 250+ Different I/O Modules
- -40°C to +85°C Operating Temperature
- Free Software Configuration Utility
- CSA Certified, FM Approved (Class I, Division 2, Groups A, B, C, D)
- CE and ATEX Compliant

ReDAQ™ Supervisory Control and Data Acquisition Software

Dataforth's **ReDAQ™ Software**, combined with one or more isoLynx® SLX200 systems, provides a total solution for factory automation, process control, test and measurement, machine control, and data acquisition applications.

Establishing a complete automation or test system with ReDAQ™ is exceptionally simple. The core software runs under Windows. This sets up the central server, which can connect to many isoLynx® SLX200 units via one or more networks. The networks can be RS-485 or dedicated Ethernets, or a combination of the two. Users then access the system via an Intranet or the Internet. No application software

is required because the HMI is delivered via Web browsers. Dynamic real-time graphical displays are generated on the Web pages by the ReDAQ™- Designer, which generates Java applets.

Being browser-based means that remote control and monitoring are readily achieved. The administrator easily creates an I/O Website using the ReDAQ™- Designer. The ReDAQ™- Designer allows dynamic real-time graphical objects such as pie charts, histograms, graphs, and mimics to be created using a graphical user interface. When viewed in the users' browsers, these graphical displays respond in

real-time to external signals. The input data to the graphics comes from the Dataforth SCM5B isolated analog signal conditioning modules that are inserted in the isoLynx® SLX200 units.

A lossless data historian is built into ReDAQ™. The historian runs automatically and continuously captures data at regular intervals. This historized data then can be used to generate history tables or graphs.

ReDAQ™ also provides for the exchange of current and historical data with other applications via XML. In addition, users can create Excel spreadsheets using current and historical data.

ReDAQ™- Server

- Generates data tables
- Generates Excel spreadsheets
- Integrated XML data exchange
- Dynamic calculations including mean, median, maximum, minimum, variance and standard deviation
- Built-in real-time, lossless historian
- No user application software required – access entirely browser-based
- Streams real-time data to ReDAQ™- Designer for graphical displays

ReDAQ™- Designer

- Generates real-time and history graphics, including:
 - Live tables
 - Graphs
 - Histograms
 - Pie charts
 - Mimics
- Evaluates math expressions using: +, -, *, /, ^, %, sqrt, sqr, sin, cos, tan, acos, asin, atan, sinh, cosh, tanh, asinh, acosh, atanh, exp, log, min, max, ceil, floor, abs, neg, and rand



Model	Description
SLX920	ReDAQ™ Software including ReDAQ™-Server and ReDAQ™- Designer

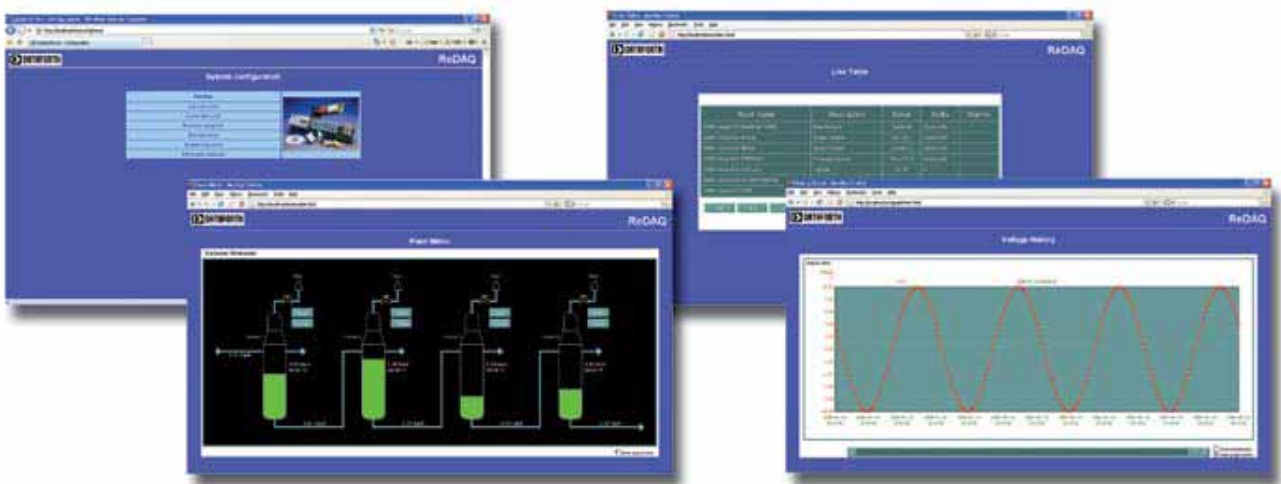

Instrument Class® Analog-to-Analog Signal Conditioning Modules, Transmitters, and Loop Isolators

Choose from the industry's largest selection of 1000+ high quality, Instrument Class® isolated analog I/O modules to condition and protect critical industrial data acquisition and control signals and valuable connected equipment. Dataforth's input modules interface to all types of external sensors and filter, isolate, amplify, and convert the input signals to high-level analog voltage or current outputs. Output modules accept high-level analog voltage signals from the host system, then buffer, isolate, and amplify before providing process current or voltage outputs to field devices.

Custom SCM5B, SCM7B, SensorLex® 8B, and DSCA signal conditioning modules as well as DSCT two-wire transmitters are available to meet your unique signal conditioning needs. We also offer a complete line of standard and DIN backpanels, cables, racks, and other accessories.

SCM5B Isolated Analog Signal Conditioning Modules

Nineteen family groups including more than 250 different **SCM5B** modules are available, encompassing a wide selection of isolated analog input and output functions.

Model	Description
SCM5B30/31	Analog Voltage Input Modules, 4Hz BW
SCM5B32	Current Input Modules, 4Hz BW
SCM5B33	True RMS Input Modules, 45Hz to 20kHz
SCM5B34	Linearized 2- or 3-Wire RTD Input Modules, 4Hz BW
SCM5B35	Linearized 4-Wire RTD Input Modules, 4Hz BW
SCM5B36	Potentiometer Input Modules, 4Hz BW
SCM5B37	Non-Linearized Thermocouple Input Modules, 4Hz BW
SCM5B38-3x	Strain Gage Input Modules, Full, 1/2, or 1/4 Bridge, 4Hz BW
SCM5B38-0x	Strain Gage Input Modules, Full, 1/2, or 1/4 Bridge, 10kHz BW
SCM5B39	Current Output Modules, 400Hz BW
SCM5B392	Matched Pair Servo/Motor Controller Drivers, 1kHz BW
SCM5B40/41	Analog Voltage Input Modules, 10kHz BW
SCM5B42	2-Wire Transmitter Interface Modules, 100Hz BW
SCM5B43	General Purpose Input Modules with Excitation, 1kHz BW
SCM5B45	Frequency Input Modules, up to 100kHz
SCM5B47	Linearized Thermocouple Input Modules, 4Hz BW
SCM5B48	Accelerometer Input Modules, Configurable, 20kHz BW
SCM5B49	Voltage Output Modules, 400Hz BW
SCM5B Accessories	1-, 2-, 8-, 16-Channel Standard and DIN Backpanels; Cables, Power Supplies, 19-inch Racks, Jumpers, Resistors, CJC

SCMVAS Isolated Voltage Attenuator System

Model	Description
SCMVAS-Mnn	Attenuator Module, 70 to 495VAC
SCM5B30-07	Voltage Input Module, 4Hz BW
SCM5B40-07	Voltage Input Module, 10kHz BW
SCM5B33-02	True RMS Input Module
SCMVAS-PB8	8-Channel Backpanel
SCMVAS-PB16	16-Channel Backpanel



The **SCM5B48** interfaces to piezo-electric sensors. Slide switches enable field-configurable settings of excitation current, signal gain, and high-pass and low-pass cutoff frequencies.

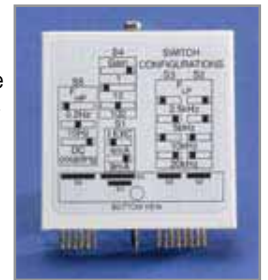

Key 5B Features and Specifications

- $\pm 0.03\%$ Accuracy (Typical)
- $\pm 0.005\%$ Linearity
- 1500Vrms Transformer Isolation & 240Vrms Field-Side Protection
- ANSI/IEEE C37.90.1 Transient Protection
- 5V Power (30mA Typical)
- 4- to 6-Pole Low-Pass Filtering
- Low Output Noise
- -40°C to $+85^{\circ}\text{C}$ Operating Temperature
- CSA Certified (Class I, Division 2, Groups A, B, C, D)
- FM Approved (Class I, Division 2, Groups A, B, C, D)
- CE and ATEX Compliant

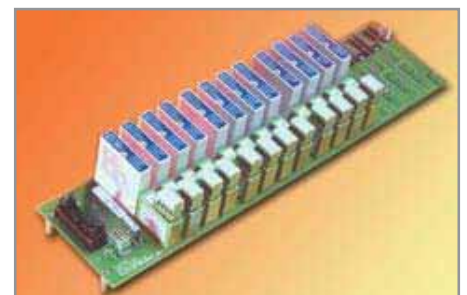

SCM7B Isolated Process Control Signal Conditioning Modules

SCM7B isolated process control signal conditioning modules provide a compact, low cost solution for industrial data acquisition and process control applications.

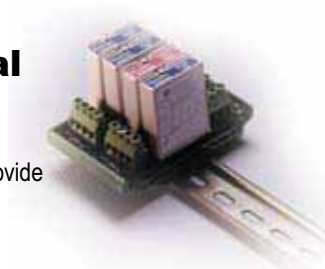

Model	Description
SCM7B21/30/31	Voltage Input Modules, 300/3/3Hz BW
SCM7B22	Voltage Output Modules, 400Hz BW
SCM7B32/33	Process Current/Voltage Input Modules, 100Hz BW
SCM7B34/34N	Linearized 2- or 3-Wire RTD Input Modules, 3Hz BW
SCM7B35	2-Wire Transmitter Interface Modules w/Loop Power, 100Hz BW
SCM7B36	Potentiometer Input Modules, 3Hz BW
SCM7B37	Non-Linearized Thermocouple Input Modules, 3Hz BW
SCM7B39	Current Output Modules, 100Hz BW
SCM7B40/41	Voltage Input Modules, 10kHz BW
SCM7B47	Linearized Thermocouple Input Modules, 3Hz BW
SCM7B Accessories	1-, 2-, 4-, 8-, 16-Channel Standard and DIN Backpanels; Cables, Power Supplies, 19-inch Racks, Resistors

Key 7B Features and Specifications

- $\pm 0.03\%$ Accuracy (Typical)
- $\pm 0.01\%$ Linearity
- 1500Vrms Transformer Isolation & 120Vrms Field-Side Protection
- ANSI/IEEE C37.90.1 Transient Protection
- Wide Supply Voltage, 14V to 35VDC
- 5-Pole Low-Pass Filtering
- Low Output Noise
- -40°C to $+85^{\circ}\text{C}$ Operating Temperature
- CSA Certified (Class I, Division 2, Groups A, B, C, D)
- FM Approved (Class I, Division 2, Groups A, B, C, D)
- CE and ATEX Compliant

SensorLex[®] 8B Isolated Analog Signal Conditioning Modules

Developed in response to customer requests worldwide for a smaller, lower cost isolated signal conditioner, Dataforth's SensorLex[®] 8B more than meets the need with 19 family groups and a total of 102 models that provide Instrument Class[®] performance and interface to a wide variety of voltage, current, temperature, position, frequency, and strain measuring devices.

Model	Description
8B30/31	Analog Voltage Input Modules, 3Hz BW
8B32	Current Input Modules, 3Hz BW
8B33	True RMS Input Modules, 45Hz to 20kHz
8B34	Linearized 2- or 3-Wire RTD Input Modules, 3Hz BW
8B35	Linearized 4-Wire RTD Input Modules, 3Hz BW
8B36	Potentiometer Input Modules, 3Hz BW
8B37	Non-Linearized Thermocouple Input Modules, 3Hz BW
8B38-0x	Strain Gage Input Modules, Full Bridge, 3kHz BW
8B38-3x	Strain Gage Input Modules, Full Bridge, 3Hz BW
8B39	Current Output Modules, 100Hz BW
8B40/41	Analog Voltage Input Modules, 1kHz BW
8B42	2-Wire Transmitter Interface Modules, 100Hz BW
8B45	Frequency Input Modules, up to 100kHz
8B47	Linearized Thermocouple Input Modules, 3Hz BW
8B49	Voltage Output Modules, 100Hz BW
8B50/51	Analog Voltage Input Modules, 20kHz BW

Key 8B Features and Specifications

- $\pm 0.05\%$ Accuracy (Typical)
- $\pm 0.02\%$ Linearity
- 1500Vrms Transformer Isolation & up to 240Vrms Field-Side Protection
- ANSI/IEEE C37.90.1 Transient Protection
- 5V Power (30mA Typical)
- 3- to 5-Pole Low-Pass Filtering
- Low Output Noise
- -40°C to $+85^{\circ}\text{C}$ Operating Temperature
- CE Compliant
- Other Agency Approvals Pending



SensorLex® 8B Isolated Analog Signal Conditioner Accessories

DIN Rail Mounting Accessory

The **8BP01-2xx** is offered as a 5VDC powered or 7VDC to 34VDC powered DIN rail mount carrier suitable for any 8B signal conditioner. The 8B carrier can be mounted on any standard DIN rail (EN 50022-35 and EN 50035-G32). The carrier measures only 3.42" x 1.48" x 0.47" (86.8mm x 37.5mm x 12mm) and has a flammability rating of UL-94 V-0.



Design-in Accessories

SensorLex® 8B backpanels provide screw-terminal inputs and outputs as well as a DB25 header connector. DB25 cables are available in 1-, 2-, and 7-meter lengths. A power supply module in the same 8B form-factor is offered for input voltages of 7VDC to 34VDC and provides 5VDC output at 2A to power any combination of 8B signal conditioners.



1-, 2-, 4-, 8-, and 16-channel standard and DIN backpanels are available for SensorLex® 8B modules

SCM9B Distributed Data Acquisition and Control Solutions

High quality **SCM9B** isolated, intelligent signal conditioning modules provide cost-effective protection and conditioning for a wide range of valuable industrial control signals and systems. Our extensive line includes fixed and programmable sensor-to-computer and computer-to-analog output interface modules, RS-232/RS-485 converters, RS-485

repeaters, and associated backplanes, accessories, and applications software. SCM9B modules are an excellent solution for distributed data acquisition applications such as process monitoring and control, remote data logging, product testing, and motion and motor speed control.

Key 9B Features and Specifications

- 500Vrms Isolation
- Programmable Scaling and Linearization
- ASCII Command/Response Protocol
- 15-Bit Measurement Resolution
- Continuous Self-Calibration
- Analog Readback
- CE Compliant

Model	Description
SCM9B-1000/2000	Sensor-to-Computer: Voltage, Current, Thermocouple, RTD, Bridge, Timer/Frequency, Digital Input Modules; User-Programmable (2000)
SCM9B-3000/4000	Computer-to-Analog Output: Voltage, Current Output Modules or User-Programmable (4000)
SCM9B-5000	Four-Channel Sensor-to-Computer: Voltage, Current, Thermocouple, Thermistor Input Modules
SCM9B-D100	DIN Rail Mount Sensor-to-Computer Modules
SCM9B-A1000/A2000	RS-232C/RS-485 Converters, RS-485 Repeaters
SCM9B Accessories	24-, 64-Point Digital I/O Boards; 8-, 14-Channel Backpanels; Utility, Data Logging, Process Control Software



DSCA High Performance, DIN Rail Mount Isolated Signal Conditioners

Each Instrument Class® DSCA module provides a single channel of isolated analog input or output for use in data acquisition, test and measurement, and control system applications.



Model	Description
DSCA30	Analog mV Input Modules, 3Hz BW
DSCA31	Analog V Input Modules, 3Hz BW
DSCA32	Current Input Modules, 100Hz BW
DSCA33	True RMS Input Modules, 45Hz to 20kHz
DSCA34	Linearized 2- or 3-Wire RTD Input Modules, 3Hz BW
DSCA36	Potentiometer Input Modules, 3Hz BW
DSCA37	Non-Linearized Thermocouple Input Modules, 3Hz BW
DSCA38	Strain Gage Input Modules, Full Bridge, 3kHz BW
DSCA39	Current Output Modules, 0 to 20mA, 4 to 20mA, -20mA to +20mA
DSCA40	Analog mV Input Modules, 3kHz BW
DSCA41	Analog V Input Modules, 3kHz BW
DSCA42	2-Wire Transmitter Interface Modules, 100Hz BW
DSCA43	General Purpose Input Modules with Excitation, 3kHz BW
DSCA45	Frequency Input Modules, up to 100kHz
DSCA47	Linearized Thermocouple Input Modules, 3Hz BW
DSCA49	V Output Modules, 1kHz BW

DSCT Versatile, Low Cost DIN Rail Mount Isolated Two-Wire Transmitters

Two-wire transmission loops are very economical methods for connecting sensors to distant control rooms. DSCT two-wire transmitters condition and send analog signals from sensors located in the "field" to monitoring and control equipment, usually computers, located thousands of feet away in central

control areas. The transmitters accept a wide range of inputs, including millivolt, volt, milliamp, thermocouple, RTD, potentiometer, and slide wire. They operate on power from a two-wire signal loop and modulate the supply current to represent the input signal within a 4 to 20mA range.

Model	Description
DSCT30	Analog Voltage Input Transmitters
DSCT32	Analog Current Input Transmitters
DSCT34	Linearized 2- or 3-Wire RTD Input Transmitters
DSCT36	Potentiometer Input Transmitters
DSCT37	Thermocouple Input Transmitters
DSCT47	Linearized Thermocouple Input Transmitters

Key DSCA Features and Specifications

- $\pm 0.03\%$ Accuracy (Typical)
- $\pm 0.01\%$ Linearity
- 1500Vrms Transformer Isolation & 240Vrms Field-Side Protection
- ANSI/IEEE C37.90.1 Transient Protection
- True 3-Way Isolation
- Wide Supply Voltage, 15V to 30VDC
- Industry Standard Output of 0 to 10V $\pm 10V$, 0 to 20mA, or 4 to 20mA
- 4- to 6-Pole Low-Pass Filtering
- Low Output Noise
- -40°C to $+80^{\circ}\text{C}$ Operating Temperature
- Plug-in Terminal Blocks Simplify Wiring
- C-UL-US Listed (Class I, Division 2, Groups A, B, C, D)
- CE and ATEX Compliant

Key DSCT Features and Specifications

- $\pm 0.03\%$ Accuracy (Typical)
- $\pm 0.01\%$ Linearity
- 1500Vrms Transformer Isolation & 240Vrms Field-Side Protection
- ANSI/IEEE C37.90.1 Transient Protection
- Wide Loop Supply Voltage, 10.8V to 60V
- 5-Pole Low-Pass Filtering
- -40°C to $+80^{\circ}\text{C}$ Operating Temperature
- Mounts on DIN Rail EN 50022, 35x7.5 or 35x15
- CE Compliant
- UL Class 1 Division 2 Pending

Wide Selection of Industrial Loop Isolators and Transmitters



DSCL, DSCP, and SCTP products form a complete family of loop and universal AC/DC-powered isolators and transmitters in DIN rail, component, and head-mount packages. The family includes basic loop-powered isolators, wide-range AC/DC-powered isolators and transmitters, and fixed-gain or hardware and software configurable models. They accept a wide range of voltage, current, thermocouple, and RTD signals, then filter, isolate, amplify, linearize, and convert the input signals to high-level analog outputs for use in data acquisition, test and measurement, and control system applications.

Key Features and Specifications

- Full Family of Loop Isolators and Transmitters
- Signal-Powered Passive Loop Isolator Models
- Jumper and Software Configurable Models
- Isolation Protection to 4000Vrms
- Wide Range 24V to 60V or 85V to 230V AC/DC-Powered Models
- Multiple Channels per Package Available
- PCB, DIN Rail, Panel, and Instrument Head Mounting Options
- CE Compliant

DSCL Loop Isolators

Model	Description
DSCL20	Loop Powered Isolator, Component Module
DSCL21	Loop Powered Isolator, DIN Rail Mount
DSCL22	Loop Powered Isolator, DIN Rail or Panel Mount
DSCL23	4 to 20mA Isolator w/DC Supply, DIN Rail or Panel Mount
DSCL24	Single- or Multi-Channel Isolator, DIN Rail or Panel Mount

DSCP and SCTP Programmable Temperature, Voltage, and Current Transmitters

Model	Description
DSCP20	2-Wire Temperature Transmitter, DIN Rail Mount
DSCP81	Isolated V/I Transmitter, DIN Rail Mount
SCTP20	2-Wire Temperature Transmitter, Head Mount
DSCP/SCTP Accessories	Module and PC Interface Cables and Configuration Software



Industrial Data Communication Products



Industrial LANs and data communication systems stretch over long distances, inside and outside, with signals exposed to electrical transients, noise, ground loops, power surges, and lightning. Commercial communication equipment often is not designed for use in these environments, which can lead to unreliable signal quality, damage to expensive peripherals, computers and other on-line equipment, and production downtime. Our heavy duty modems "harden" and protect these systems, and can extend communications for many miles without expensive cabling.

LDM Limited Distance Data Modems and Converters

Model	Description
LDM30	Low Cost, General Purpose Limited Distance Modem, RS-232
LDM35	Signal-Powered Limited Distance Modem, RS-232
LDM70	Fully Isolated Limited Distance Modem, RS-232
LDM422	Isolated Limited Distance Modem, RS-232/RS-422 Converter
LDM485	Isolated Limited Distance Modem, RS-232/RS-485 Converter
LDM80	Signal-Powered Fiber Optic Modem, RS-232
LDM85	Fiber Optic Modem, High Speed 5M Baud, RS-232/422/423, TTL

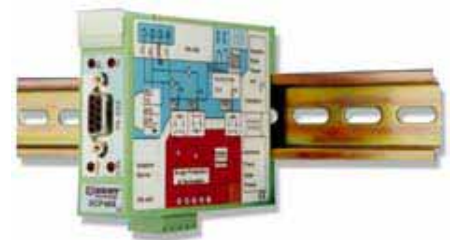

DCP DIN Rail Mount Industrial Data Products

Model	Description
DCP485	Fully Isolated RS-232/RS-485 Converter
DCP35	Signal-Powered RS-232 Line Driver, 1-Channel or 2-Channel

Key Features and Specifications

- Protects Equipment from Damage due to Power Surges, Transients, Lightning
- 1500Vrms Isolation with Optocouplers and Power DC-to-DC Converter (6000VDC, 1 min)
- Extends RS-232 Communication Distances without Expensive Low-Capacitance Cabling
- Connects RS-232 Devices to RS-422 and RS-485 Devices
- Data Rates to 115k Baud
- Distances to 12 Miles (20km)
- CE Compliant





Visit Dataforth's Full-Service Website

Dataforth's full-service Website is an easy-to-use, comprehensive source for sales, product, and applications information. The site includes:

- Fast, accurate parametric search capabilities for all Dataforth industrial signal conditioning, data acquisition, and data communication products
- On-line product quote and purchase
- On-line product data sheets, application notes, and user manuals
- Direct applications assistance, sales, and customer service help lines readily available
- Latest news on company operations and new products
- Comprehensive signal conditioning, data acquisition, and control tutorial
- Worldwide corporate and sales contact information

On-Line Help

On-Line Ordering

Data Sheets

Application Notes

Product Information





High Performance Industrial Signal Conditioning, Data Acquisition,
and Data Communication Products Since 1984

WORLD HEADQUARTERS

Dataforth Corporation

3331 E. Hemisphere Loop
Tucson, AZ 85706 USA
Toll Free: 800-444-7644
Tel: 520-741-1404
Fax: 520-741-0762
Email: sales@dataforth.com

Dataforth Europe

Werkstrasse 1
D-84513 Töging am Inn, Germany
Tel: +49.8631.308111
Fax: +49.8631.308118
Email: datafortheurope@dataforth.eu

Dataforth Asia

6F-2, 190 Chuang-Ching Road
Taipei 110, Taiwan
Tel: +886-2-2758-9697
Fax: +886-2-8788-2571
Email: dataforthasia@dataforth.com



**The Dataforth Quality
Management System is
ISO9001:2000 Registered**

www.dataforth.com