

# 190/191



## COMPACT SIZE WITH TWO JAW STYLES



JAW STYLE 1



JAW STYLE 2

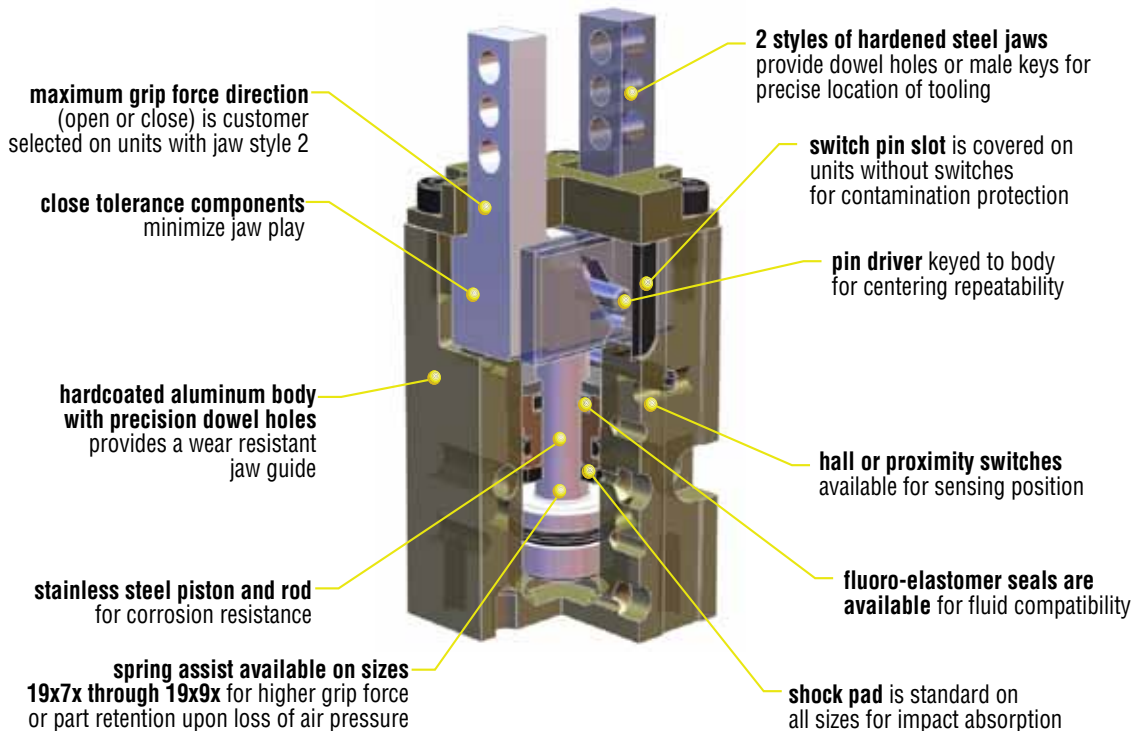

190, 191

### Major Benefits

- Compact size
- Spring assist on open or close  
Spring assist available on sizes 19x7x through 19x9x  
Spring assist available in four sizes, two jaw styles, two jaw travels
- Mounting holes on one or three surfaces
- Jaw travel adjustment kits available
- 1 day shipping
- 10 million cycles minimum rated life with standard seals (includes spring assist units)

### Industry Uses

- Assembly machine builders
- Light bulb manufacturing
- Vehicle lighting equipment
- Medical
- Batteries
- Bearing manufacturing

# ORDERING DATA: SERIES 190 & 191 PARALLEL GRIPPERS

190, 191

## TO ORDER SPECIFY:

Model, Design No., Sensor or Switch Ready Options, Maximum Force, Spring Options, and Seals.

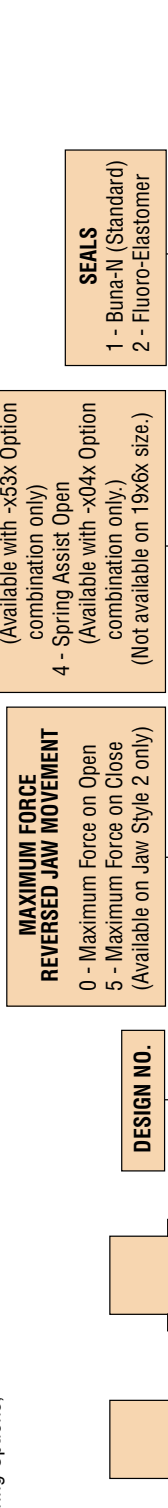

**HALL EFFECT SENSOR KITS**

GRIPPER MODEL	PART NUMBER IMPERIAL	METRIC
19x6x	18674-04	18057-04
19x7x	18675-04	18058-04
19x8x	18676-04	18059-04
19x9x	18677-04	18060-04

Sensors must be ordered separately. See Switches and Sensors section.

**SWITCH BRACKETS & TARGET KITS FOR USE WITH:**

**PHD SERIES 5580 SWITCHES**

GRIPPER MODEL	PART NUMBER IMPERIAL	METRIC
19x6x	59794-1	55770
19x7x	59795-1	55771
19x8x	55772	55772
19x9x	55773	55773

Switches must be ordered separately. See Switches and Sensors section.

**SWITCH BRACKETS & TARGETS FOR INDUCTIVE PROXIMITY SWITCHES**

GRIPPER MODEL	PART NUMBER IMPERIAL	METRIC
19x6x	59792-1	18432
19x7x	59793-1	18437
19x8x	18438	18438
19x9x	18439	18439

Switches must be ordered separately. See Switches and Sensors section.

MODEL	BORE SIZE	190 MODELS			191 MODELS		
		FULL MOUNTING		BOTTOM MOUNTING		SHORT TRAVEL	
JAW STYLE 1	mm	IMPERIAL	JAW STYLE 1	IMPERIAL	JAW STYLE 1	IMPERIAL	JAW STYLE 1
19x6x	8.7	19060	19065	19160	19165	19161	19166
19x7x	12.7	19070	19075	19170	19175	19171	19176
19x8x	19	19080	19085	19180	19185	19181	19186
19x9x	25.4	19090	19095	19190	19195	19191	19196
JAW STYLE 2	mm	IMPERIAL	JAW STYLE 2	IMPERIAL	JAW STYLE 2	IMPERIAL	JAW STYLE 2
19x6x	8.7	19061	19066	19161	19166	19162	19167
19x7x	12.7	19071	19076	19171	19176	19172	19177
19x8x	19	19081	19086	19181	19186	19182	19187
19x9x	25.4	19091	19096	19191	19196	19182	19187
SHORT TRAVEL	mm	IMPERIAL	SHORT TRAVEL	IMPERIAL	SHORT TRAVEL	IMPERIAL	SHORT TRAVEL
19x6x	8.7	19062	19067	19162	19167	19162	19167
19x7x	12.7	19072	19077	19172	19177	19172	19177
19x8x	19	19082	19087	19182	19187	19182	19187
19x9x	25.4	19092	19097	19192	19197	19182	19187
LONG TRAVEL	mm	IMPERIAL	LONG TRAVEL	IMPERIAL	LONG TRAVEL	IMPERIAL	LONG TRAVEL
19x6x	8.7	19062	19067	19162	19167	19162	19167
19x7x	12.7	19072	19077	19172	19177	19172	19177
19x8x	19	19082	19087	19182	19187	19182	19187
19x9x	25.4	19092	19097	19192	19197	19182	19187

**NOTES:**  
 1) Sensor must be used with a PHD Set Point Module.  
 2) Switches and all kits must be ordered separately.



UNIQUE GRIPPERS ARE AVAILABLE. SEE PAGES 4-179 TO 4-204.

# ENGINEERING DATA: SERIES 190 & 191 PARALLEL GRIPPERS

SPECIFICATIONS	SERIES 190 & 191
OPERATING PRESSURE	30 psi min to 150 psi max [2 bar min to 10 bar max] air
OPERATING TEMPERATURE	-20° to +180°F [-28° to +82°C]
RATED LIFE	10 million cycles minimum with standard seals (including spring assist units)
GRIP REPEATABILITY	Within ±0.002 in [±0.05 mm] of original centered position
LUBRICATION	Factory lubricated for rated life
MAINTENANCE	Field repairable

GRIPPER NO.	DISPLACEMENT		GRIPPER WEIGHT				GRIP FORCE FACTOR $G_F$				SPRING ASSIST GRIP FORCE $S_F$	
			STANDARD		SPRING ASSIST		MAX. DIRECTION		MIN. DIRECTION		Imperial	Metric
	in <sup>3</sup>	cm <sup>3</sup>	lb	kg	oz	g	Imperial*	Metric*	Imperial	Metric		
19x60 & 19x65	.012	0.2	0.11	0.05	—	—	.061	3.93	.049	3.16	—	—
19x61 & 19x66	.012	0.2	0.11	0.05	—	—	.061	3.93	.049	3.16	—	—
19x62 & 19x67	.012	0.2	0.13	0.06	—	—	.037	2.39	.029	1.87	—	—
19x70 & 19x75	.036	0.6	0.24	0.11	0.26	0.12	.122	7.87	.092	5.93	2.230	9.99
19x71 & 19x76	.036	0.6	0.25	0.11	0.26	0.12	.122	7.87	.092	5.93	2.230	9.99
19x72 & 19x77	.036	0.6	0.27	0.12	0.28	0.12	.093	6.00	.069	4.45	1.690	7.57
19x80 & 19x85	.110	1.8	0.64	0.29	0.65	0.29	.250	16.13	.210	13.55	4.280	19.17
19x81 & 19x86	.110	1.8	0.67	0.30	0.68	0.31	.250	16.13	.210	13.55	4.280	19.17
19x82 & 19x87	.110	1.8	0.71	0.32	0.73	0.33	.150	9.68	.130	8.39	2.630	11.78
19x90 & 19x95	.250	4.1	1.44	0.65	1.47	0.67	.490	31.61	.370	23.87	8.700	38.98
19x91 & 19x96	.250	4.1	1.46	0.66	1.48	0.67	.490	31.61	.370	23.87	8.700	38.98
19x92 & 19x97	.250	4.1	1.62	0.73	1.64	0.74	.270	17.42	.200	12.90	4.760	21.32

\*Maximum grip force direction is always open (internal grip) on all Series 190 and 191 Jaw Style One units. (19x60, 19x65, 19x70, 19x75, 19x80, 19x85, 19x90, and 19x95)

190, 191

## TOOLING LENGTH FACTOR

Jaw tooling should be designed so that the grip point is as close to the body surface as possible. As the grip point is moved away from the body surface, the applied moment causes jaw friction to increase, resulting in reduced effective grip force. The grip force factor ( $G_F$ ) values given in the table above are for zero tooling length (body surface).

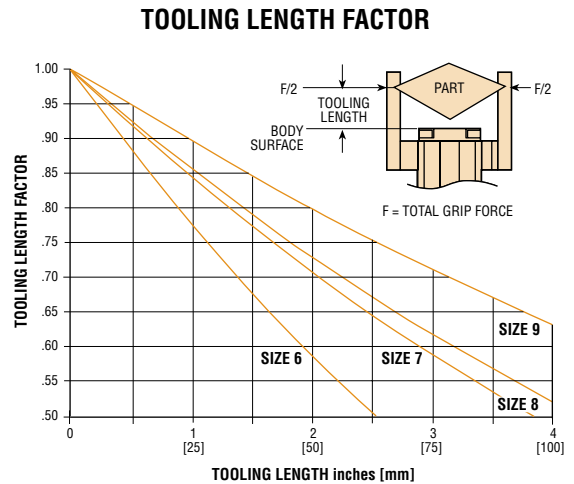

## GRIP FORCE CALCULATION EQUATIONS:

### IMPERIAL:

**TOTAL GRIP FORCE [lb] = (Pressure [psi] x  $G_F$ ) x Tooling Length Factor**

**TOTAL GRIP FORCE WITH SPRINGS [lb] = ((Pressure [psi] x  $G_F$ ) ±  $S_F$  [lb]) x Tooling Length Factor**

### METRIC:

**TOTAL GRIP FORCE [N] = (Pressure [bar] x  $G_F$ ) x Tooling Length Factor**

**TOTAL GRIP FORCE WITH SPRINGS [N] = ((Pressure [bar] x  $G_F$ ) ±  $S_F$  [N]) x Tooling Length Factor**

**SIZING AND APPLICATION ASSISTANCE**  
 See PHD Product Sizing Catalog for specific and complete sizing information.  
 Online sizing assistance is available at: [www.phdinc.com/apps/sizing](http://www.phdinc.com/apps/sizing)

# DIMENSIONS: SERIES 190 PARALLEL GRIPPERS - JAW STYLE 1

## FULL MOUNTING IN POSITIONS 3 & 4

LETTER DIM.	MODEL NUMBER							
	19060 in	19065 mm	19070 in	19075 mm	19080 in	19085 mm	19090 in	19095 mm
NOMINAL JAW TRAVEL	.157	4	.276	7	.394	10	.512	13
A CLOSED**	.315	7.75	.345	8.75	.581	14.75	.700	17.75
A OPEN**	.403	10.25	.540	13.75	.915	23.25	1.150	29.25
B	.787	20.0	1.024	26.0	1.496	38.0	1.968	50.0
C	.398	10.0	.555	14.0	.791	20.0	1.027	26.0
D	.177	4.5	.215	5.5	.256	6.5	.394	10.0
F	.312	8.0	.375	10.0	.500	12.0	.625	16.0
G	#4	M2.5	#5	M3	#8	M4	#10	M5
H	1.012	25.5	1.289	32.0	1.635	41.0	2.081	53.0
K	1.563	39.5	1.937	48.5	2.500	63.5	3.242	82.5
L	.098	2.5	.138	3.5	.196	5.0	.256	6.5
M	1.031	26.01	1.249	31.0	1.624	41.0	2.108	53.5
O*	.5310	14.0	.6875	18.0	.8430	22.0	1.0940	28.0
P*	.550	14.0	.710	18.0	1.100	28.0	1.535	39.0
Q	4-40 x .19 DP	M3 x 0.5 x 4.5 DP	6-32 x .22 DP	M3 x 0.5 x 4.5 DP	8-32 x .28 DP	M4 x 0.7 x 6.0 DP	10-24 x .38 DP	M5 x 0.8 x 7.5 DP
R	.601	15.5	.681	18.0	.785	20.5	.870	22.0
S	1.312	33.0	1.624	40.0	2.062	52.0	2.655	67.5
T	.351	8.5	.367	9.0	.380	9.5	.322	8.0
W	3/32	2.5	1/8	3.0	1/8	4.0	3/16	5.0
Y	.196	5.0	.276	7.0	.393	10.0	.511	13.0
Z	#4	M3	#6	M3	#8	M4	#10	M5
AA	.871	22.0	1.045	26.0	1.412	36.0	1.854	47.0
BB	10-32	M3 x 0.5	10-32	M3 x 0.5	10-32	M5 x 0.8	10-32	M5 x 0.8
CC	.167	3.0	.176	3.5	.193	5.5	.153	4.5
DD	.465	12.5	.505	14.5	.592	15.0	.750	19.5
EE	1/16	2.5	1/16	2.5	1/16	3.0	1/16	3.0

### NOTES:

- \* TOLERANCE BETWEEN DOWEL PIN HOLES IS  $\pm .0008$  [ $\pm 0.02$ ]
- NUMBERS IN [ ] ARE FOR METRIC UNITS AND ARE IN mm
- CIRCLED NUMBERS INDICATE POSITIONS.
- \*\* A CLOSED REFLECTS THE LARGEST POSSIBLE CLOSED DIMENSION.  
A OPEN REFLECTS THE SMALLEST POSSIBLE OPEN DIMENSION.

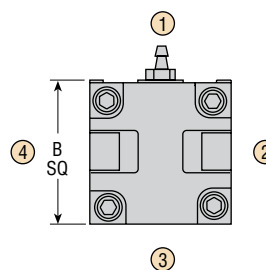
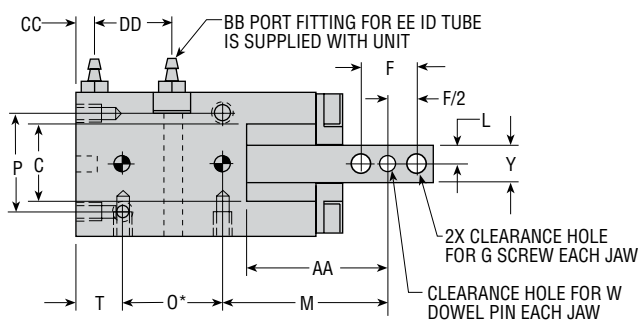
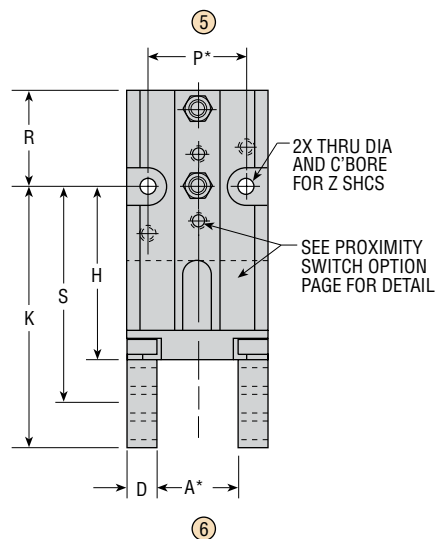
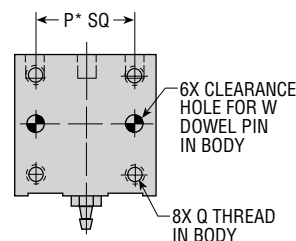

# DIMENSIONS: SERIES 190 PARALLEL GRIPPERS - JAW STYLE 2

## FULL MOUNTING IN POSITIONS 3 & 4

LETTER DIM.	MODEL NUMBER							
	19061/62	19066/67	19071/72	19076/77	19081/82	19086/87	19091/92	19096/97
	in	mm	in	mm	in	mm	in	mm
NOMINAL JAW TRAVEL								
SHORT	.157	4	.276	7	.394	10	.512	13
LONG	.315	8	.433	11	.630	16	.866	22
A CLOSED*	1.054	26.75	1.329	33.75	1.841	46.75	2.353	59.75
A OPEN*	1.151	29.25	1.545	39.25	2.175	55.25	2.805	71.25
AL CLOSED*	1.447	36.75	1.802	45.75	2.353	59.75	2.865	72.75
AL OPEN*	1.702	43.25	2.175	55.25	2.923	74.25	3.671	93.25
B	.787	20.0	1.024	26.0	1.496	38.0	1.968	50.0
C	.398	10.0	.555	14.0	.791	20.0	1.027	26.0
D	.3937	10.0	.4921	12.5	.7480	19.0	.9842	25.0
F	.188	5.0	.250	6.5	.375	10.0	.625	12.0
G	3-56 x .18 DP	M2.5 x 0.45 x 5.0 DP	6-32 x .28 DP	M3 x 0.5 x 6.0 DP	8-32 x .32 DP	M4 x 0.7 x 8.0 DP	10-24 x .38 DP	M5 x 0.8 x 10.0 DP
H	1.012	25.5	1.289	32.0	1.635	41.0	2.081	53.0
K	.159	4.0	.204	5.0	.212	5.5	.254	6.5
L	.098	2.5	.138	3.5	.197	5.0	.256	6.5
M	.553	14.0	.696	17.5	.960	24.0	1.238	31.5
O**	.5310	14.0	.6875	18.0	.8430	22.0	1.0940	28.0
P**	.550	14.0	.710	18.0	1.100	28.0	1.535	39.0
Q	4-40 x .19 DP	M3 x 0.5 x 4.5 DP	6-32 x .22 DP	M3 x 0.5 x 4.5 DP	8-32 x .28 DP	M4 x 0.7 x 6.0 DP	10-24 x .38 DP	M5 x 0.8 x 7.5 DP
R	.601	15.5	.681	18.0	.785	20.5	.870	22.0
S	.834	21.0	1.071	26.5	1.398	35.0	1.785	45.5
T	.351	8.5	.367	9.0	.380	9.5	.322	8.0
W	3/32	2.5	1/8	3.0	1/8	4.0	3/16	5.0
Y	.1970 ±.0006	5.0 ±0.015	.2756 ±.0006	7.0 ±0.015	.3940 ±.0007	10.0 ±0.018	.5118 ±.0008	13.0 ±0.020
Z	#4	M3	#6	M3	#8	M4	#10	M5
AA	.103	2.5	.121	3.0	.186	4.5	.180	6.5
BB	10-32	M3 x 0.5	10-32	M3 x 0.5	10-32	M5 x 0.8	10-32	M5 x 0.8
CC	.167	3.0	.176	3.5	.193	5.5	.153	4.5
DD	.465	12.5	.505	14.5	.592	15.0	.750	19.5
EE	1/16	2.5	1/16	2.5	1/16	3.0	1/16	3.0

### NOTES:

- 1) \*A CLOSED & OPEN ARE FOR MODELS 19061, 71, 81, 91, 66, 76, 86, & 96  
AL CLOSED & OPEN ARE FOR MODELS 19062, 72, 82, 92, 67, 77, 87, & 97
- 2) \*\*TOLERANCE BETWEEN DOWEL PIN HOLES IS ± .0008 [±0.02]
- 3) CIRCLED NUMBERS INDICATE POSITIONS.
- 4) \*A OR AL CLOSED REFLECTS THE LARGEST POSSIBLE CLOSED DIMENSION.  
A OR AL OPEN REFLECTS THE SMALLEST POSSIBLE OPEN DIMENSION.

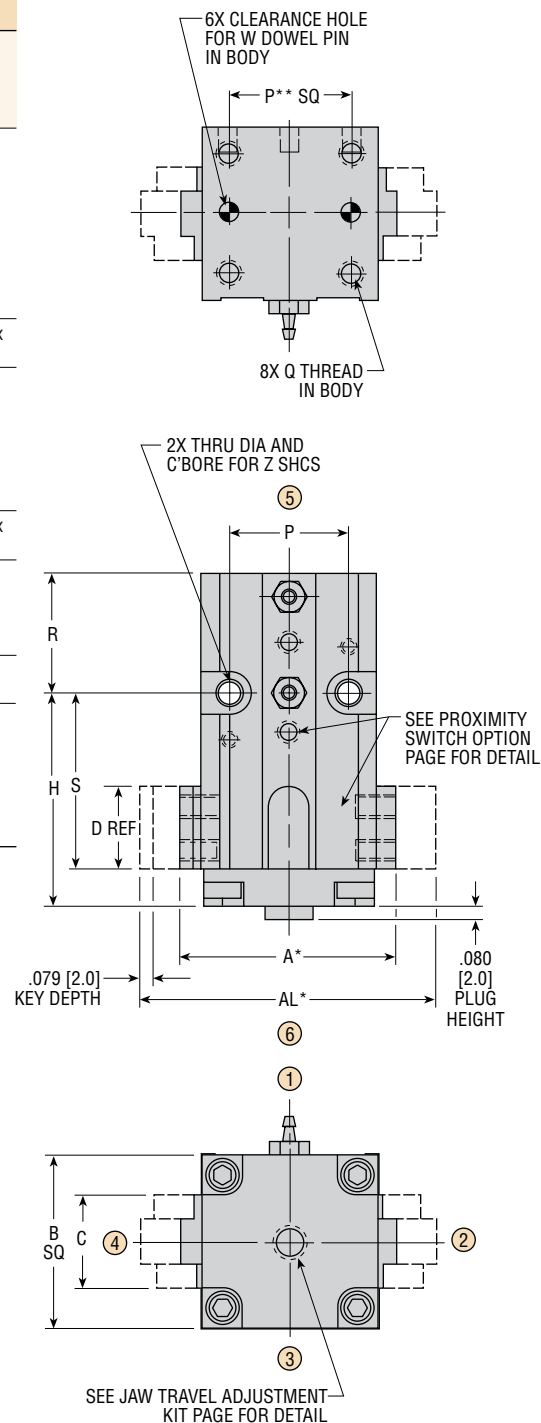
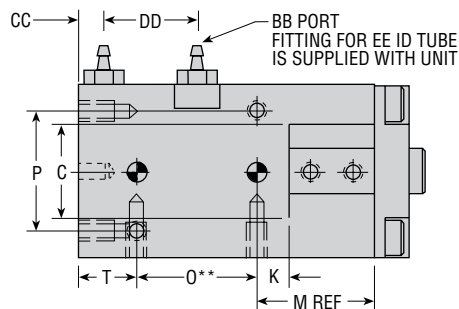
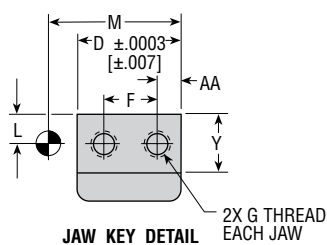

190, 191

All dimensions are reference only unless specifically tolerated.

www.phdinc.com/190191 • (800) 624-8511

4-121

PHDV1

# DIMENSIONS: SERIES 191 PARALLEL GRIPPERS - JAW STYLE 1

## BOTTOM MOUNTING ONLY

LETTER DIM.	MODEL NUMBER							
	19160	19165	19170	19175	19180	19185	19190	19195
	in	mm	in	mm	in	mm	in	mm
NOMINAL JAW TRAVEL	.157	4	.276	7	.394	10	.512	13
A CLOSED**	.315	7.75	.345	8.75	.581	14.75	.700	17.75
A OPEN**	.403	10.25	.540	13.75	.915	23.25	1.150	29.25
B	.787	20.0	1.024	26.0	1.496	38.0	1.968	50.0
C	.398	10.0	.555	14.0	.791	20.0	1.027	26.0
D	.177	4.5	.215	5.5	.256	6.5	.394	10.0
F	.312	8.0	.375	10.0	.500	12.0	.625	16.0
G	#4	M2.5	#5	M3	#8	M4	#10	M5
H	1.613	41.0	1.970	50.0	2.420	61.5	2.951	75.0
K	2.164	55.0	2.618	66.5	3.285	83.5	4.112	104.5
L	.098	2.5	.138	3.5	.196	5.0	.256	6.5
M	1.913	48.5	2.305	58.5	2.847	72.5	3.525	89.5
P*	.550	14.0	.710	18.0	1.100	28.0	1.535	39.0
Q	4-40 x .19 DP	M3 x 0.5 x 4.5 DP	6-32 x .22 DP	M3 x 0.5 x 4.5 DP	8-32 x .28 DP	M4 x 0.7 x 6.0 DP	10-24 x .38 DP	M5 x 0.8 x 7.5 DP
R	3/32	2.5	1/8	3.0	1/8	4.0	3/16	5.0
S	.871	22.0	1.045	26.0	1.412	36.0	1.854	47.0
T	.167	3.0	.176	3.5	.193	5.5	.153	4.5
W	.465	12.5	.505	14.5	.592	15.0	.750	19.5
Y	.196	5.0	.276	7.0	.393	10.0	.511	13.0
Z	10-32	M3 x 0.5	10-32	M3 x 0.5	10-32	M5 x 0.8	10-32	M5 x 0.8
EE	1/16	2.5	1/16	2.5	1/16	3.0	1/16	3.0

### NOTES:

- 1) \*TOLERANCE BETWEEN DOWEL PIN HOLES IS  $\pm .0008$  [ $\pm 0.02$ ]
- 2) NUMBERS IN [ ] ARE FOR METRIC UNITS AND ARE IN mm
- 3) CIRCLED NUMBERS INDICATE POSITIONS.
- 4) \*\*A CLOSED REFLECTS THE LARGEST POSSIBLE CLOSED DIMENSION.  
A OPEN REFLECTS THE SMALLEST POSSIBLE OPEN DIMENSION.

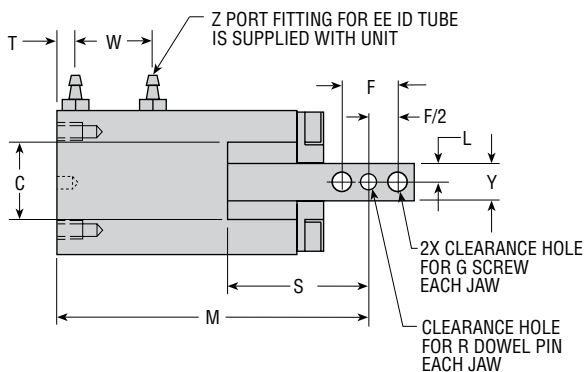
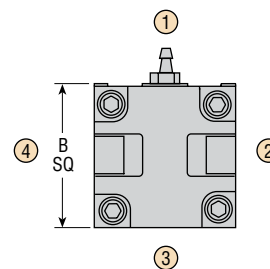
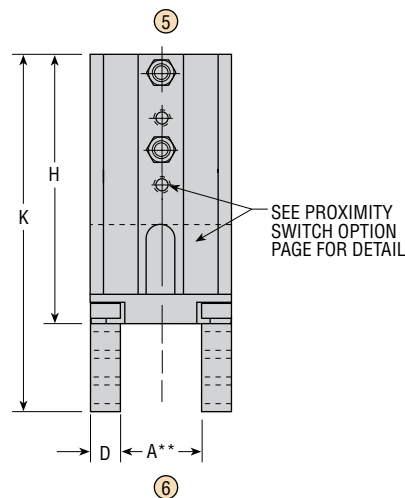
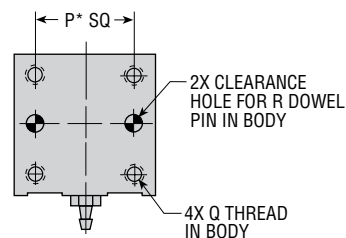

# DIMENSIONS: SERIES 191 PARALLEL GRIPPERS - JAW STYLE 2

## BOTTOM MOUNTING ONLY

LETTER DIM.	MODEL NUMBER							
	19161/62 in	19166/67 mm	19171/72 in	19176/77 mm	19181/82 in	19186/87 mm	19191/92 in	19196/97 mm
NOMINAL JAW TRAVEL								
SHORT	.157	4	.276	7	.394	10	.512	13
LONG	.315	8	.433	11	.630	16	.866	22
A CLOSED*	1.054	26.75	1.329	33.75	1.841	46.75	2.353	59.75
A OPEN*	1.151	29.25	1.545	39.25	2.175	55.25	2.805	71.25
AL CLOSED*	1.447	36.75	1.802	45.75	2.353	59.75	2.865	72.75
AL OPEN*	1.702	43.25	2.175	55.25	2.923	74.25	3.671	93.25
B	.787	20.0	1.024	26.0	1.496	38.0	1.968	50.0
C	.398	10.0	.555	14.0	.791	20.0	1.027	26.0
D	.3937	10.0	.4921	12.5	.7480	19.0	.9842	25.0
F	.188	5.0	.250	6.5	.375	10.0	.625	12.0
G	3-56 x .18 DP	M2.5 x 0.45 x 5.0 DP	6-32 x .28 DP	M3 x 0.5 x 6.0 DP	8-32 x .32 DP	M4 x 0.7 x 8.0 DP	10-24 x .38 DP	M5 x 0.8 x 10.0 DP
H	1.613	41.0	1.970	50.0	2.420	61.5	2.951	75.0
K	.103	2.5	.121	3.0	.186	4.5	.180	6.5
L	.098	2.5	.138	3.5	.197	5.0	.256	6.5
M	1.435	36.5	1.752	44.5	2.183	55.5	2.655	67.5
P**	.550	14.0	.710	18.0	1.100	28.0	1.535	39.0
Q	4-40 x .19 DP	M3 x 0.5 x 4.5 DP	6-32 x .22 DP	M3 x 0.5 x 4.5 DP	8-32 x .28 DP	M4 x 0.7 x 6.0 DP	10-24 x .38 DP	M5 x 0.8 x 7.5 DP
R	3/32	2.5	1/8	3.0	1/8	4.0	3/16	5.0
T	.167	3.0	.176	3.5	.193	5.5	.153	4.5
W	.465	12.5	.505	14.5	.592	15.0	.750	19.5
Y	.1970	5.0	.2756	7.0	.3940	10.0	.5118	13.0
	±.0006	±0.015	±.0006	±0.015	±.0007	±0.018	—	—
Z	10-32	M3 x 0.5	10-32	M3 x 0.5	10-32	M5 x 0.8	10-32	M5 x 0.8
EE	1/16	2.5	1/16	2.5	1/16	3.0	1/16	3.0

### NOTES:

- \*A CLOSED AND OPEN ARE FOR MODELS 19161, 71, 81, 91, 66, 76, 86, & 96  
AL CLOSED & OPEN ARE FOR MODELS 19162, 72, 82, 92, 67, 77, 87, & 97
- \*\*TOLERANCE BETWEEN DOWEL PIN HOLES IS ± .0008 [±0.02]
- CIRCLED NUMBERS INDICATE POSITIONS.
- \*A CLOSED REFLECTS THE LARGEST POSSIBLE CLOSED DIMENSION.  
A OPEN REFLECTS THE SMALLEST POSSIBLE OPEN DIMENSION.

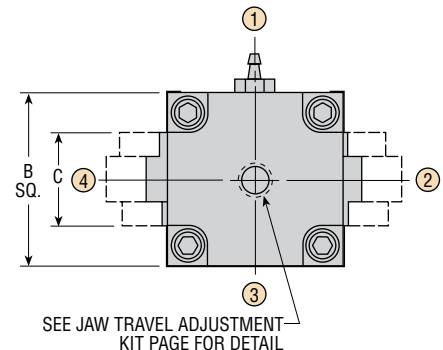
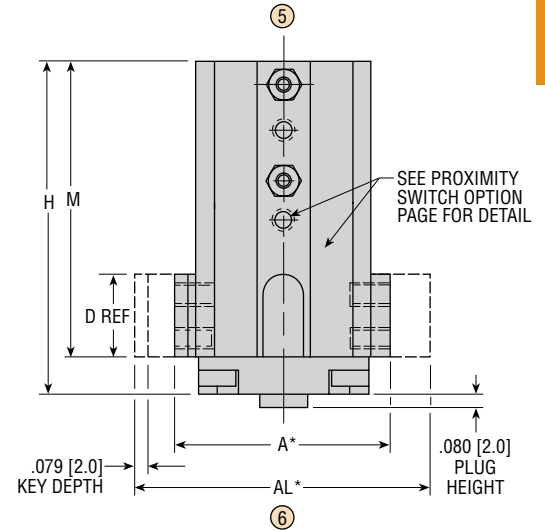
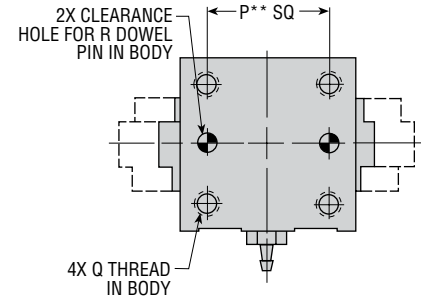
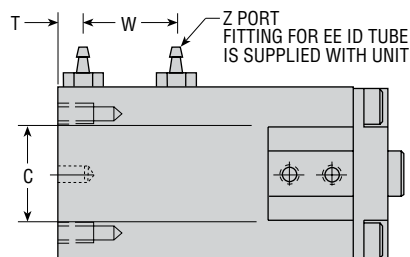
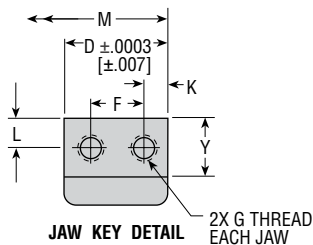

190, 191

All dimensions are reference only unless specifically tolerated.

www.phdinc.com/190191 • (800) 624-8511

# OPTIONS & ACCESSORIES: SERIES 190 & 191 PARALLEL

## 4 HALL SENSOR READY

This option provides unit installed with magnet for use with PHD Hall Sensor. Kits must be ordered separately.

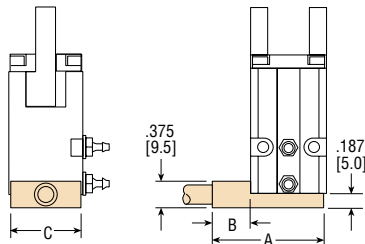

NUMBERS IN [ ] ARE FOR METRIC UNITS AND ARE IN mm

MODEL NO.	KIT NO.		LETTER DIM.		
	IMPERIAL	METRIC	A	B	C
19x6x	18674-04	18057-04	1.431 [36.5]	.650 [16.5]	.777 [20.0]
19x7x	18675-04	18058-04	1.556 [39.5]	.550 [14.0]	.974 [25.0]
19x8x	18676-04	18059-04	1.800 [46.0]	.295 [7.5]	1.486 [38.0]
19x9x	18677-04	18060-04	2.272 [58.0]	.295 [7.5]	1.958 [50.0]

EACH HALL SENSOR KIT CONTAINS THE FOLLOWING ITEMS:  
ONE SENSOR WITH A 12 FOOT [4 m] SHIELDED CABLE TWO MOUNTING SCREWS

- 1) THE SENSOR MAY BE ROTATED TO ALLOW THE CABLE TO EXTEND FROM ANY SIDE OF UNIT EXCEPT THE PORT SIDE.
- 2) SENSOR MOUNTS TO UNIT USING BOTTOM MOUNTING HOLES. GRIPPERS MAY BE MOUNTED USING THESE HOLES. BUT THE SENSOR MUST BE SANDWICHED BETWEEN PLATE AND GRIPPER USING LONGER CUSTOMER SUPPLIED SCREWS.

## 5 PROXIMITY SWITCH READY

This option provides the grippers with a pin to mount a switch target for 6 mm square inductive or Hall Effect proximity switch. See additional information below for details on switch bracket/target kits.

### SERIES 5580 HALL EFFECT SWITCHES

MODEL NO.	DESCRIPTION
55803-1-02	NPN 4.5-24 VDC with 2 meter cable
55804-1-02	PNP 4.5-24 VDC with 2 meter cable
55823-1	NPN 4.5-24 VDC with Quick Connect
55824-1	PNP 4.5-24 VDC with Quick Connect

### 6 mm SQUARE INDUCTIVE PROXIMITY SWITCHES

MODEL NO.	DESCRIPTION
18431-001-02	NPN 10-30 VDC with 2 meter cable
18431-002-02	PNP 10-30 VDC with 2 meter cable

## SWITCH BRACKET AND TARGET KITS

### FOR IMPERIAL MODELS 19x6x AND 19x7x ONLY

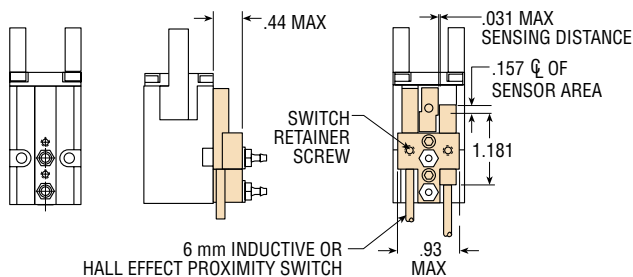

EACH SWITCH BRACKET & TARGET KIT CONTAINS THE FOLLOWING ITEMS:  
1 TARGET WITH SCREW  
BRACKET FOR 6 mm SQUARE SWITCH AND ALL MOUNTING COMPONENTS

SWITCHES ARE ORDERED SEPARATELY

#### FOR USE WITH: SERIES 5580 SWITCHES

GRIPPER MODEL	SWITCH BRACKET & TARGET KIT
19x6x	59794-1
19x7x	59795-1

#### FOR USE WITH: 6 mm SQUARE INDUCTIVE PROXIMITY SWITCHES

GRIPPER MODEL	SWITCH BRACKET & TARGET KIT
19x6x	59792-1
19x7x	59793-1

### FOR IMPERIAL MODELS 19x8x & 19x9x METRIC MODELS 19x6x, 19x7x, 19x8x, & 19x9x

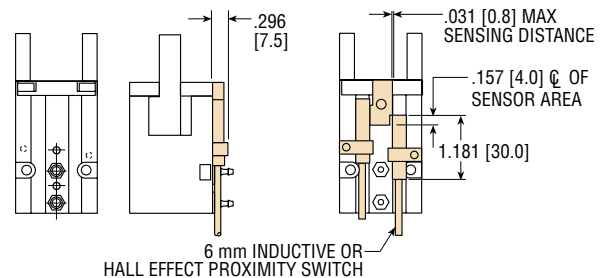

EACH SWITCH BRACKET & TARGET KIT CONTAINS THE FOLLOWING ITEMS:  
1 TARGET WITH SCREW  
2 SENSOR BRACKETS WITH MOUNTING SCREWS

SWITCHES ARE ORDERED SEPARATELY  
NUMBERS IN [ ] ARE FOR METRIC UNITS AND ARE IN mm

#### FOR USE WITH: SERIES 5580 SWITCHES

GRIPPER MODEL	SWITCH BRACKET & TARGET KIT
19x6x*	55770
19x7x*	55771
19x8x	55772
19x9x	55773

\* METRIC UNITS ONLY

#### FOR USE WITH: 6 mm SQUARE INDUCTIVE PROXIMITY SWITCHES

GRIPPER MODEL	SWITCH BRACKET & TARGET KIT
19x6x*	18432
19x7x*	18437
19x8x	18438
19x9x	18439

\* METRIC UNITS ONLY



# ACCESSORIES & JAW TOOLING: SERIES 190 & 191 PARALLEL

## JAW TRAVEL ADJUSTMENT KIT

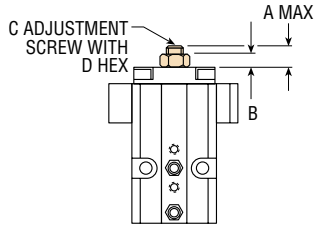

MODEL NO.	KIT NO.	LETTER DIM.			
		A	B	C	D
19x6x	18433	.197 [5.0]	.094 [2.4]	[M3 x 10.0]	.05 [1.3]
19x7x	18434	.315 [8.0]	.157 [4.0]	[M5 x 14.0]	.094 [2.4]
19x8x	18435	.394 [10.0]	.197 [5.0]	[M6 x 18.0]	.125 [3.2]
19x9x	18436	.591 [15.0]	.315 [8.0]	[M10 x 22.0]	.188 [4.8]

NUMBERS IN [ ] ARE FOR METRIC UNITS AND ARE IN mm

JAW TRAVEL ADJUSTMENT AVAILABLE ON STYLE 2 JAWS ONLY (19xx1, 19xx2, 19xx6, AND 19xx7 MODELS).

EACH JAW TRAVEL ADJUSTMENT KIT CONTAINS THE FOLLOWING ITEMS: ONE ADJUSTMENT SCREW AND NUT

TRAVEL CAN ONLY BE ADJUSTED IN THE MAX FORCE DIRECTION OF ANY MODEL.

**EXAMPLE 1:** A MAX FORCE CLOSE GRIPPER; TRAVEL IS ONLY VARIED IN THE CLOSE DIRECTION, TRAVEL IN THE OPEN DIRECTION REMAINS UNCHANGED.

**EXAMPLE 2:** A MAX FORCE OPEN GRIPPER; TRAVEL IS ONLY VARIED IN THE OPEN DIRECTION, TRAVEL IN THE CLOSE DIRECTION REMAINS UNCHANGED.

The Jaw Travel Adjustment Kit contains a screw and a lock nut used to limit the jaw opening on Jaw Style 2 parallel grippers. Jaw travel can be adjusted from zero opening to maximum opening. Below is one application example showing how the jaw travel

adjustment kit can be of benefit. If the option of maximum grip force on jaw closure is specified, (-x5xx option) the adjustment kit will limit the travel in the closing direction.

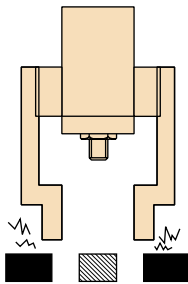

With jaws fully open, the tooling hits the obstruction and the part cannot be gripped.

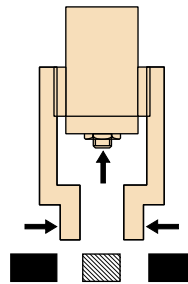

Turning jaw travel adjustment screw inward reduces the maximum open position; allowing the tooling to clear the obstruction.

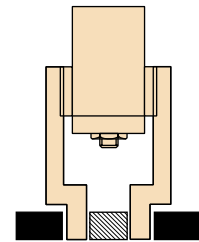

The part can now be gripped. (The jaw closed dimension is not affected by the jaw travel adjustment.)

190, 191

## JAW TOOLING

### JAW STYLE 1

Jaw Style 1 is ideally suited for small parts. Simple tooling can provide a long narrowed profile for small parts or for reaching into confined areas.

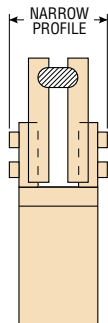

### JAW STYLE 2

Jaw Style 2 allows simple tooling of wide parts. This type of tooling keeps the part close to the unit for a low profile package.

Jaw Style 2 provides the lowest profile assembly for internal gripping by keeping the tooling close to the gripper.

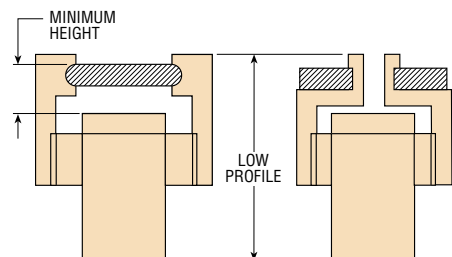

### DOWEL PINS

Style 1 jaw is provided with a dowel pin hole as a means of orienting and locating jaw tooling.

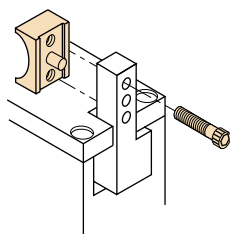

### MALE KEY

Style 2 jaws have a close tolerance\* male key for orientation and precise location of jaw tooling.

Jaw tooling can be readily machined to include a mating slot for the jaw key.

