

ITT Enidine Heavy Duty Series large-bore hydraulic shock absorbers protect equipment from large impacts in applications such as automated storage and retrieval systems, as well as overhead bridge and trolley cranes. They are available in a wide variety of stroke lengths and damping characteristics to increase equipment life and meet stringent deceleration requirements.

HDN Series

Custom-orificed design accommodates specified damping requirements. Computer generated output performance simulation is used to optimize the orifice configuration. Available in standard bore dimensions of up to 4 in. (100mm) and strokes over 60 in. (1524mm).

HDA Series

Adjustable units enable the user to modify shock absorber resistance to accommodate load velocity variations, with strokes up to 12in. (305mm). Standard adjustable configurations available.



HDN Series

Features and Benefits HDN, HDA

- Designed with Environmentally friendly materials and fluids
- Compact design smoothly and safely decelerates large energy capacity loads up to 3,000,000 in-lbs. per cycle (330 000 Nm)
- Internal charged air/oil accumulator replaces mechanical return springs, providing shorter overall length and reduced weight.
Optional Bladder Accumulator (BA) for higher cycle rates also available.
- Engineered to meet OSHA, AISE, CMAA and other safety specifications such as DIN and FEM.
- Wide variety of optional configurations including bellows, clevis mounts and safety cables.
- Painted external components provide excellent corrosion protection.
- Epoxy painting and special rod materials are available for use in highly corrosive environments.
- All sizes are fully field repairable.
- Piston rod extension sensor systems available for re-use safety requirements.
- Incorporating optional fluids and seal packages can expand standard operating temperature range from 15°F to 140°F (-10°C to 60°C) to -30°F to 210°F (-35°C to 100°C)

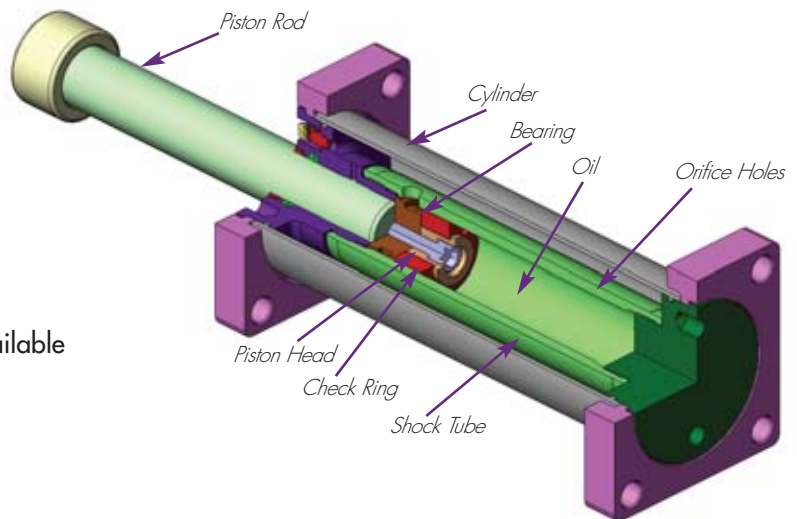

Heavy Duty Shock Absorbers

HDN 1.5 Series

Technical Data

HDN 1.5 x 2 → HDN 1.5 x 32 Series

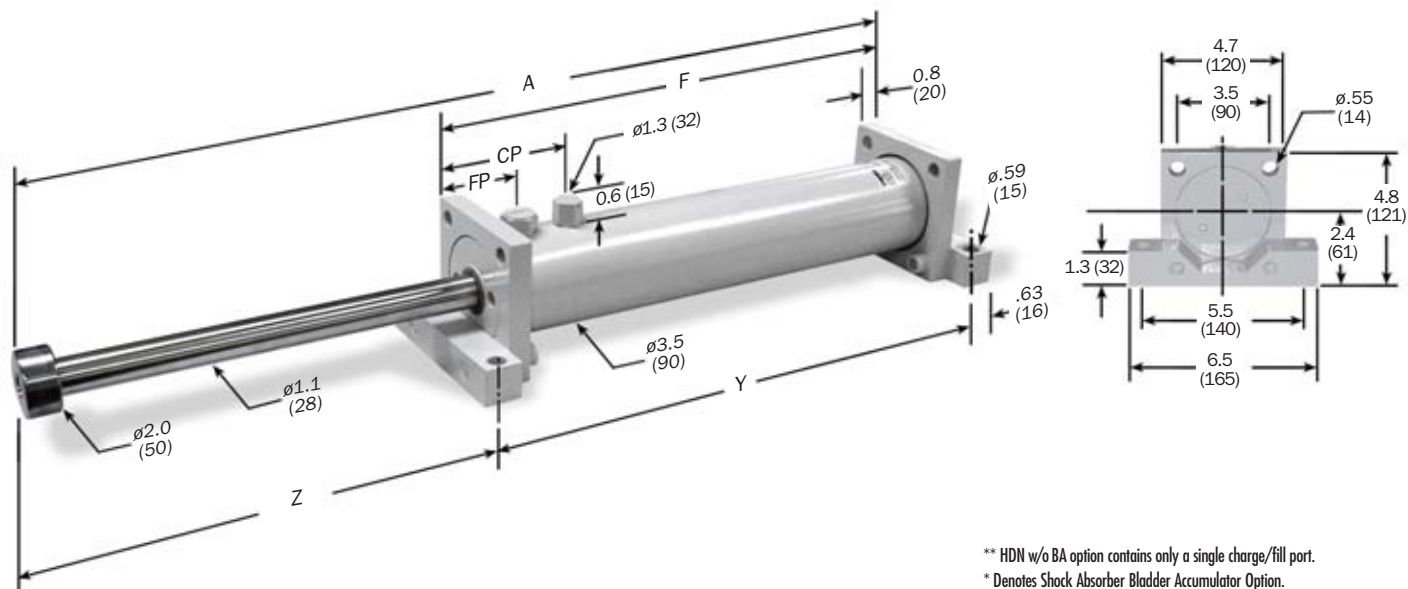

Dimensions are in inches (millimeters).

** HDN w/o BA option contains only a single charge/fill part.
* Denotes Shock Absorber Bladder Accumulator Option.
Note: For TF, FF and FR mounting, delete front foot and dimensions.

Catalog No./Model	(S) Stroke in. (mm)	(E _T) Max. in.-lbs./cycle (Nm/cycle)	(E _{T-C}) Max. in.-lbs./hour (Nm/hr)	(F _P) Max. Shock Force lbs. (N)	Nominal Return Force BA* lbs. (N)	Nominal Return Force w/o BA* lbs. (N)	A in. (mm)	F in. (mm)	Y in. (mm)	Z in. (mm)	With BA		CP** w/o BA* in. (mm)	Model Weight lbs. (Kg)
											CP BA* in. (mm)	FP BA* in. (mm)		
HDN 1.5 x 2	2 (50)	27,900 (3 200)	1,676,000 (189 000)	15,750 (70 060)	50 (220)	70 (320)	12.2 (310)	8.2 (208)	9.4 (240)	3.4 (86)	5.5 (139)	3.4 (86)	1.6 (41)	22 (10)
HDN 1.5 x 4	4 (100)	54,200 (6 100)	3,257,300 (368 000)	15,750 (70 060)	50 (220)	90 (410)	16.1 (410)	10.2 (258)	11.4 (290)	5.4 (136)	5.5 (139)	3.4 (86)	1.6 (41)	24 (12)
HDN 1.5 x 6	6 (150)	80,600 (9 100)	4,838,500 (546 700)	15,750 (70 060)	50 (220)	100 (450)	20.1 (510)	12.1 (308)	13.4 (340)	7.3 (186)	5.5 (139)	3.4 (86)	1.6 (41)	26 (12)
HDN 1.5 x 8	8 (200)	108,000 (12 200)	6,482,900 (732 500)	15,750 (70 060)	50 (220)	120 (525)	24.1 (613)	14.2 (360)	15.4 (392)	9.3 (237)	5.5 (139)	3.4 (86)	1.6 (41)	29 (13)
HDN 1.5 x 10	10 (250)	134,900 (15 200)	6,912,000 (781 000)	15,750 (70 060)	50 (220)	135 (600)	28.2 (715)	16.2 (411)	17.4 (443)	11.3 (288)	5.5 (139)	3.4 (86)	1.6 (41)	31 (14)
HDN 1.5 x 12	12 (300)	161,800 (18 300)	7,769,700 (877 900)	15,750 (70 060)	50 (220)	210 (920)	32.2 (817)	18.2 (462)	19.4 (494)	13.3 (339)	5.5 (139)	3.4 (86)	1.6 (41)	35 (16)
HDN 1.5 x 14	14 (350)	185,100 (20 900)	8,610,500 (972 900)	15,750 (70 060)	50 (220)	250 (1 120)	36.1 (918)	20.2 (512)	21.4 (544)	15.4 (390)	5.5 (139)	3.4 (86)	1.6 (41)	37 (17)
HDN 1.5 x 16	16 (400)	208,300 (23 300)	9,468,200 (1 069 800)	13,500 (60 060)	50 (220)	250 (1 120)	40.1 (1 019)	22.2 (563)	23.4 (595)	17.3 (440)	5.5 (139)	3.4 (86)	1.6 (41)	40 (18)
HDN 1.5 x 18	18 (450)	224,300 (25 300)	10,325,900 (1 166 700)	10,750 (47 820)	50 (220)	250 (1 120)	44.1 (1 121)	24.2 (614)	25.4 (646)	19.3 (491)	5.5 (139)	3.4 (86)	1.6 (41)	42 (19)
HDN 1.5 x 20	20 (500)	240,300 (27 200)	11,183,600 (1 263 600)	8,750 (38 920)	50 (220)	250 (1 120)	48.2 (1 223)	26.2 (665)	27.4 (697)	21.4 (542)	5.5 (139)	3.4 (86)	1.6 (41)	44 (20)
HDN 1.5 x 24	24 (600)	269,600 (30 500)	12,899,000 (1 457 400)	6,250 (27 800)	50 (220)	250 (1 120)	56.2 (1 427)	30.2 (767)	31.5 (799)	21.3 (544)	5.5 (139)	3.4 (86)	1.6 (41)	50 (23)
HDN 1.5 x 28	28 (713)	297,000 (33 600)	14,597,600 (1 649 300)	4,750 (21,130)	50 (220)	250 (1 120)	64.1 (1 629)	34.2 (868)	35.4 (900)	29.3 (745)	5.5 (139)	3.4 (86)	1.6 (41)	44 (20)
HDN 1.5 x 32	32 (813)	322,800 (36 500)	16,279,300 (1 839 300)	3,700 (16 460)	50 (220)	250 (1 120)	72.0 (1 830)	38.1 (968)	39.4 (1 000)	33.3 (846)	5.5 (139)	3.4 (86)	1.6 (41)	50 (23)

- Notes: 1. HDN shock absorbers will function satisfactorily at 5% of their maximum rated energy per cycle. If less than these values, a smaller model should be specified.
2. It is recommended that the customer consult ITT Enidine for safety-related overhead crane applications.
3. The energy data listed is for ideal linear impacts only. If side load conditions exist in the application, contact ITT Enidine for sizing assistance.
4. Rear flange mounting of 12 inch (300 mm) strokes and longer not recommended. Front and rear flange or foot mount configurations are recommended.
5. Maximum cycle rate is 60 cycles/hr. for HDN with BA (Bladder Accumulator) option and 30 cycles/hr. without BA option.
6. For impact velocities over 180 in./sec. (4.5 m/s), consult factory.

Heavy Duty Series Shock Absorber

HDN 2.0 Series

Technical Data

HDN 2.0 x 6 → HDN 2.0 x 56 Series

Heavy Duty Series

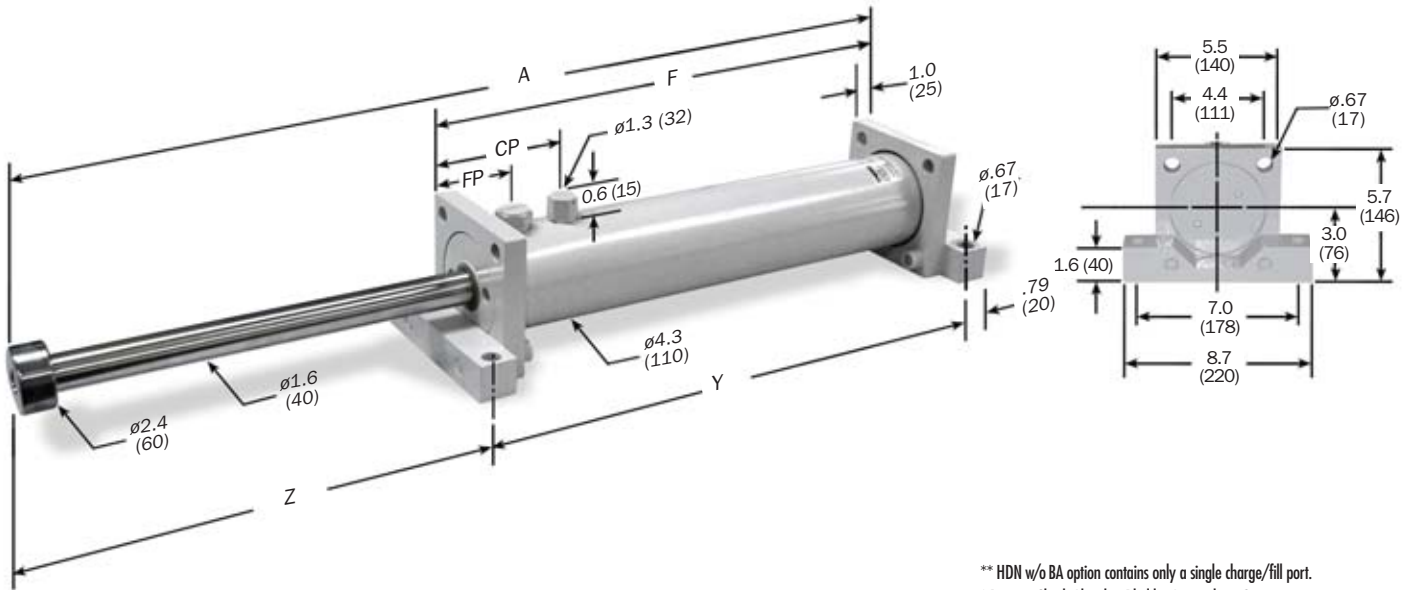

Dimensions are in inches (millimeters).

** HDN w/o BA option contains only a single charge/fill port.
* Denotes Shock Absorber Bladder Accumulator Option.
Note: For TF, FF and FR mounting, delete front foot and dimensions.

Catalog No./ Model	(S) Stroke in. (mm)	(E _T) Max. in.-lbs./cycle (Nm/cycle)	(E _T C) Max. in.-lbs./hour (Nm/hr)	(F _P) Max. Shock Force lbs. (N)	Nominal Return Force BA* lbs. (N)	Nominal Return Force w/o BA* lbs. (N)	A in. (mm)	F in. (mm)	Y in. (mm)	Z in. (mm)	With BA		CP** w/o BA* in. (mm)	Model Weight lbs. (Kg)
											CP BA* in. (mm)	FP BA* in. (mm)		
HDN 2.0 x 6	6 (152)	127,200 (14 400)	7,629,900 (862 100)	25,000 (111 200)	120 (535)	200 (870)	21.8 (553)	13.3 (339)	14.9 (379)	7.6 (194)	6.9 (176)	3.8 (96)	1.8 (46)	51 (23)
HDN 2.0 x 8	8 (203)	169,800 (19 200)	8,086,900 (913 700)	25,000 (111 200)	120 (535)	235 (1 040)	25.8 (655)	15.4 (390)	16.9 (430)	9.6 (245)	6.9 (176)	3.8 (96)	1.8 (46)	55 (25)
HDN 2.0 x 10	10 (250)	212,500 (24 000)	9,144,400 (1 033 200)	25,000 (111 200)	120 (535)	300 (1 340)	29.8 (757)	17.4 (441)	18.9 (481)	11.7 (296)	6.9 (176)	3.8 (96)	1.8 (46)	51 (23)
HDN 2.0 x 12	12 (300)	253,200 (28 600)	10,201,900 (1 152 700)	25,000 (111 200)	120 (535)	515 (2 290)	33.8 (859)	19.4 (492)	20.9 (532)	13.7 (347)	6.9 (176)	3.8 (96)	1.8 (46)	55 (25)
HDN 2.0 x 14	14 (350)	285,900 (32 300)	11,259,500 (1 272 100)	25,000 (111 200)	120 (535)	515 (2 290)	37.8 (960)	21.4 (543)	23.0 (583)	15.6 (397)	6.9 (176)	3.8 (96)	1.8 (46)	60 (27)
HDN 2.0 x 16	16 (400)	318,700 (36 000)	12,317,000 (1 391 600)	25,000 (111 200)	120 (535)	515 (2 290)	41.8 (1 062)	23.4 (594)	25.0 (634)	17.6 (448)	6.9 (176)	3.8 (96)	1.8 (46)	64 (29)
HDN 2.0 x 18	18 (450)	351,500 (39 700)	13,374,500 (1 511 100)	25,000 (111 200)	120 (535)	515 (2 290)	45.8 (1 164)	25.4 (645)	27.0 (685)	19.6 (499)	6.9 (176)	3.8 (96)	1.8 (46)	68 (31)
HDN 2.0 x 20	20 (500)	383,600 (43 300)	14,411,300 (1 628 300)	25,000 (111 200)	120 (535)	515 (2 290)	49.8 (1 265)	27.4 (695)	28.9 (735)	21.7 (550)	6.9 (176)	3.8 (96)	1.8 (46)	73 (33)
HDN 2.0 x 24	24 (600)	449,100 (50 700)	16,526,300 (1 867 200)	25,000 (111 200)	120 (535)	515 (2 290)	57.8 (1 469)	31.4 (797)	33.0 (837)	25.7 (652)	6.9 (176)	3.8 (96)	1.8 (46)	79 (36)
HDN 2.0 x 28	28 (700)	514,678 (58 200)	18,641,400 (2 106 200)	25,000 (111 200)	120 (535)	515 (2 290)	65.8 (1 672)	35.4 (899)	37.0 (939)	29.6 (753)	6.9 (176)	3.8 (96)	1.8 (46)	93 (42)
HDN 2.0 x 32	32 (800)	625,600 (70 700)	22,373,800 (2 527 900)	25,000 (111 200)	120 (535)	515 (2 290)	76.9 (1 953)	42.5 (1 079)	44.1 (1 119)	33.6 (854)	10.1 (256)	6.9 (176)	1.8 (46)	108 (49)
HDN 2.0 x 36	36 (900)	689,500 (77 900)	24,447,300 (2 762 200)	22,500 (100 000)	120 (535)	515 (2 290)	84.7 (2 151)	46.4 (1 179)	48.0 (1 219)	37.5 (952)	10.1 (256)	6.9 (176)	1.8 (46)	117 (53)
HDN 2.0 x 40	40 (1 000)	746,700 (84,400)	26,520,900 (2 996 500)	19,000 (84 500)	120 (535)	515 (2 290)	92.6 (2 351)	50.4 (1 279)	51.9 (1 319)	41.4 (1 052)	10.1 (256)	6.9 (176)	1.8 (46)	124 (56)
HDN 2.0 x 48	48 (1 200)	844,100 (95 400)	30,668,000 (3 465 000)	13,500 (60 000)	120 (535)	515 (2 290)	108.3 (2 751)	58.2 (1 479)	59.8 (1 519)	49.3 (1 252)	10.1 (256)	6.9 (176)	1.8 (46)	141 (64)
HDN 2.0 x 56	56 (1 400)	922,300 (104 200)	35,022,500 (3 957 000)	7,900 (35 100)	120 (535)	515 (2 290)	124.8 (3 171)	66.5 (1 689)	68.1 (1 729)	57.6 (1 462)	10.1/38.4** (256/975)	6.9 (176)	1.8 (46)	161 (73)

- Notes: 1. HDN shock absorbers will function satisfactorily at 5% of their maximum rated energy per cycle. If less than these values, a smaller model should be specified.
2. It is recommended that the customer consult ITT Enidine for safety-related overhead crane applications.
3. The energy data listed is for ideal linear impacts only. If side load conditions exist in the application, contact ITT Enidine for sizing assistance.
4. Rear flange mounting of 12 inch (300 mm) strokes and longer not recommended. Front and rear flange or foot mount configurations are recommended.
5. Maximum cycle rate is 60 cycles/hr. for HDN with BA (Bladder Accumulator) option and 30 cycles/hr. without BA option.
6. For impact velocities over 180 in./sec. (4.5 m/s), consult factory.
7. ** HDN 2.0 x 56 has two charge ports.

Heavy Duty Series Shock Absorber

HDN 3.0 Series

HDN 3.0 x 2 → HDN 3.0 x 60 Series

Technical Data

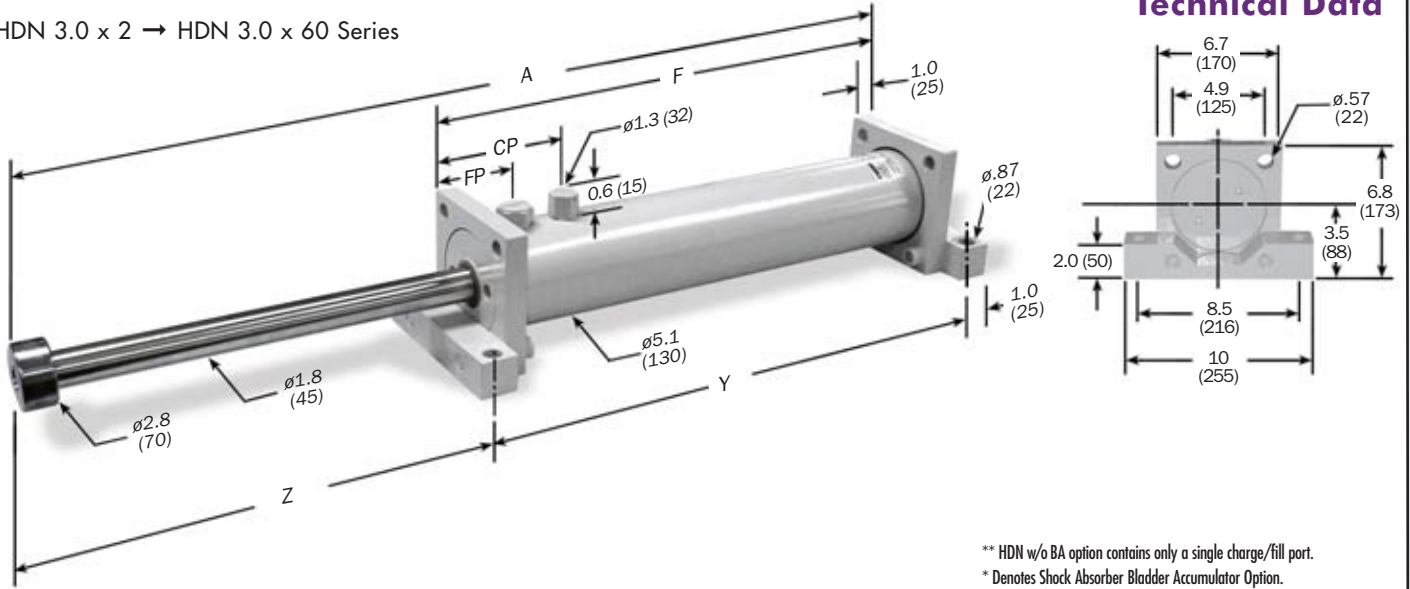

** HDN w/o BA option contains only a single charge/fill port.
 * Denotes Shock Absorber Bladder Accumulator Option.
 Note: For TF, FF and FR mounting, delete front foot and dimensions.

Catalog No./ Model	(S) Stroke in. (mm)	(F _T) Max. in.-lbs./cycle (Nm/cycle)	(F _C) Max. in.-lbs./hour (Nm/hr)	(F _P) Max. Initial Shock Force lbs. (N)	Nominal Return Force BA*	Nominal Return Force w/o BA*	A in. (mm)	F in. (mm)	Y in. (mm)	Z in. (mm)	With BA		CP** w/o BA* in. (mm)	Model Weight lbs. (Kg)
											CP BA* in. (mm)	FP BA* in. (mm)		
HDN 3.0 x 2	2 (50)	85,300 (9 600)	5,120,100 (578 500)	50,000 (222 400)	150 (670)	255 (1 130)	13.2 (336)	8.0 (203)	10.0 (253)	4.3 (108)	5.0 (128)	2.4 (61)	1.8 (46)	40 (21)
HDN 3.0 x 3	3 (75)	128,800 (14 600)	5,832,300 (659 000)	50,000 (222 400)	160 (710)	405 (1 810)	15.2 (387)	9.0 (229)	11.0 (279)	5.2 (133)	5.0 (128)	2.4 (61)	1.8 (46)	42 (22)
HDN 3.0 x 5	5 (125)	214,200 (24 200)	7,131,200 (805 700)	50,000 (222 400)	165 (735)	650 (2 895)	19.3 (489)	11.0 (280)	13.0 (330)	7.2 (184)	5.0 (128)	2.4 (61)	1.8 (46)	48 (25)
HDN 3.0 x 8	8 (200)	316,100 (35 700)	9,041,400 (1 021 500)	50,000 (222 400)	170 (755)	650 (2 895)	25.2 (640)	14.0 (355)	15.9 (405)	10.2 (260)	5.0 (128)	2.4 (61)	1.8 (46)	57 (29)
HDN 3.0 x 10	10 (250)	382,600 (43 200)	10,340,300 (1 168 300)	50,000 (222 400)	175 (780)	650 (2 895)	29.2 (742)	16.0 (406)	18.0 (456)	12.2 (311)	5.0 (128)	2.4 (61)	1.8 (46)	64 (32)
HDN 3.0 x 12	12 (300)	449,100 (50 700)	11,639,200 (1 315 000)	50,000 (222 400)	175 (780)	650 (2 895)	33.2 (844)	18.0 (457)	20.0 (507)	14.3 (362)	5.0 (128)	2.4 (61)	1.8 (46)	71 (35)
HDN 3.0 x 14	14 (350)	556,500 (62 900)	14,211,500 (1 605 700)	50,000 (222 400)	180 (800)	650 (2 895)	39.2 (995)	22.0 (558)	23.9 (608)	16.2 (412)	7.0 (178)	4.4 (111)	1.8 (46)	88 (43)
HDN 3.0 x 16	16 (400)	623,000 (70 400)	15,510,400 (1 752 400)	50,000 (222 400)	180 (800)	650 (2 895)	43.2 (1 097)	24.0 (609)	25.9 (659)	18.2 (463)	7.0 (178)	4.4 (111)	1.8 (46)	93 (45)
HDN 3.0 x 18	18 (450)	689,400 (77 900)	16,809,300 (1 899 200)	50,000 (222 400)	180 (800)	650 (2 895)	47.2 (1 199)	26.0 (660)	28.0 (710)	20.2 (514)	7.0 (178)	4.4 (111)	1.8 (46)	99 (48)
HDN 3.0 x 20	20 (500)	755,900 (85 400)	18,108,200 (2 046 000)	50,000 (222 400)	180 (800)	650 (2 895)	51.2 (1 301)	28.0 (711)	30.0 (761)	22.2 (565)	7.0 (178)	4.4 (111)	1.8 (46)	106 (51)
HDN 3.0 x 24	24 (600)	887,600 (100 300)	20,680,500 (2 336 600)	50,000 (222 400)	180 (800)	650 (2 895)	59.2 (1 504)	32.0 (812)	33.9 (862)	26.3 (667)	7.0 (178)	4.4 (111)	1.8 (46)	119 (57)
HDN 3.0 x 28	28 (700)	1,020,600 (115 300)	23,278,300 (2 630 100)	50,000 (222 400)	180 (800)	650 (2 895)	67.2 (1 707)	36.0 (914)	38.0 (964)	30.2 (768)	7.0 (178)	4.4 (111)	1.8 (46)	130 (62)
HDN 3.0 x 32	32 (800)	1,152,200 (130 200)	25,850,700 (2 920 700)	40,500 (180 200)	180 (800)	650 (2 895)	75.2 (1 910)	40.0 (1 015)	41.9 (1 065)	34.3 (870)	7.0 (178)	6.3 (161)	1.8 (46)	143 (68)
HDN 3.0 x 36	36 (900)	1,307,100 (147 700)	29,645,500 (3 349 500)	36,000 (160 100)	180 (800)	650 (2 895)	84.9 (2 156)	45.8 (1 164)	47.8 (1 214)	38.1 (967)	9.0 (228)	6.3 (161)	1.8 (46)	163 (77)
HDN 3.0 x 40	40 (1 000)	1,412,700 (159 600)	32,192,300 (3 637 200)	31,500 (140 000)	180 (800)	650 (2 895)	92.8 (2 356)	49.8 (1 264)	51.7 (1 314)	42.0 (1 067)	9.0 (228)	6.3 (161)	1.8 (46)	176 (85)
HDN 3.0 x 48	48 (1 200)	1,590,700 (179 700)	37,286,100 (4 212 800)	21,500 (95 600)	185 (825)	650 (2 895)	108.5 (2 756)	57.6 (1 464)	59.6 (1 514)	49.9 (1 267)	9.0 (228)	6.3 (161)	1.8 (46)	200 (94)
HDN 3.0 x 56	56 (1 400)	1,741,300 (196 700)	42,379,800 (4 788 300)	12,500 (55 600)	185 (825)	650 (2 895)	124.3 (3 156)	65.5 (1 664)	67.5 (1 714)	57.8 (1 467)	9.0/37.3** (228)/(947)	6.3 (161)	1.8 (46)	235 (106)
HDN 3.0 x 60	60 (1 500)	1,830,400 (206 800)	45,283,200 (5 116 300)	11,950 (53 200)	185 (825)	650 (2 895)	133.2 (3 384)	70.0 (1 778)	72.0 (1 828)	62.2 (1 581)	9.0/39.5** (228)/(1004)	6.3 (161)	1.8 (46)	235 (106)
HDN 3.0 x 64	64 (1 629)	1,921,500 (217 100)	46,116,000 (5 210 400)	11,950 (53 200)	185 (825)	650 (2 895)	145.2 (3 688)	78.0 (1 980)	79.9 (2 030)	66.3 (1 683)	12.9/60.1 (439)/(1 527)	10.2 (260)	1.8 (46)	245 (110)
HDN 3.0 x 72	72 (1 830)	2,106,500 (238 000)	55,245,000 (6 242 000)	11,950 (53 200)	185 (825)	650 (2 895)	158.0 (4 012)	82.5 (2 092)	84.5 (2 142)	74.6 (1 895)	17.3/68.0 (439)/(1 727)	10.2 (260)	1.8 (46)	260 (118)

Notes: 1. HDN shock absorbers will function satisfactorily at 5% of their maximum rated energy per cycle. If less than these values, a smaller model should be specified.
 2. It is recommended that the customer consult ITT Enidine for safety-related overhead crane applications.
 3. The energy data listed is for ideal linear impacts only. If side load conditions exist in the application, contact ITT Enidine for sizing assistance.
 4. Rear flange mounting of 12 inch (300 mm) strokes and longer not recommended. Front and rear flange or foot mount configurations are recommended.
 5. Maximum cycle rate is 60 cycles/hr. for HDN with BA option and 30 cycles/hr. without BA (Bladder Accumulator) option.
 6. For impact velocities over 180 in./sec. (4.5 m/s), consult factory.
 7. ** HDN 3.0 x 56 and HDN 3.0 x 60 have 2 charge ports.

Heavy Duty Series Shock Absorber

HDN 3.5 Series

Technical Data

HDN 3.5 x 2 → HDN 3.5 x 56 Series

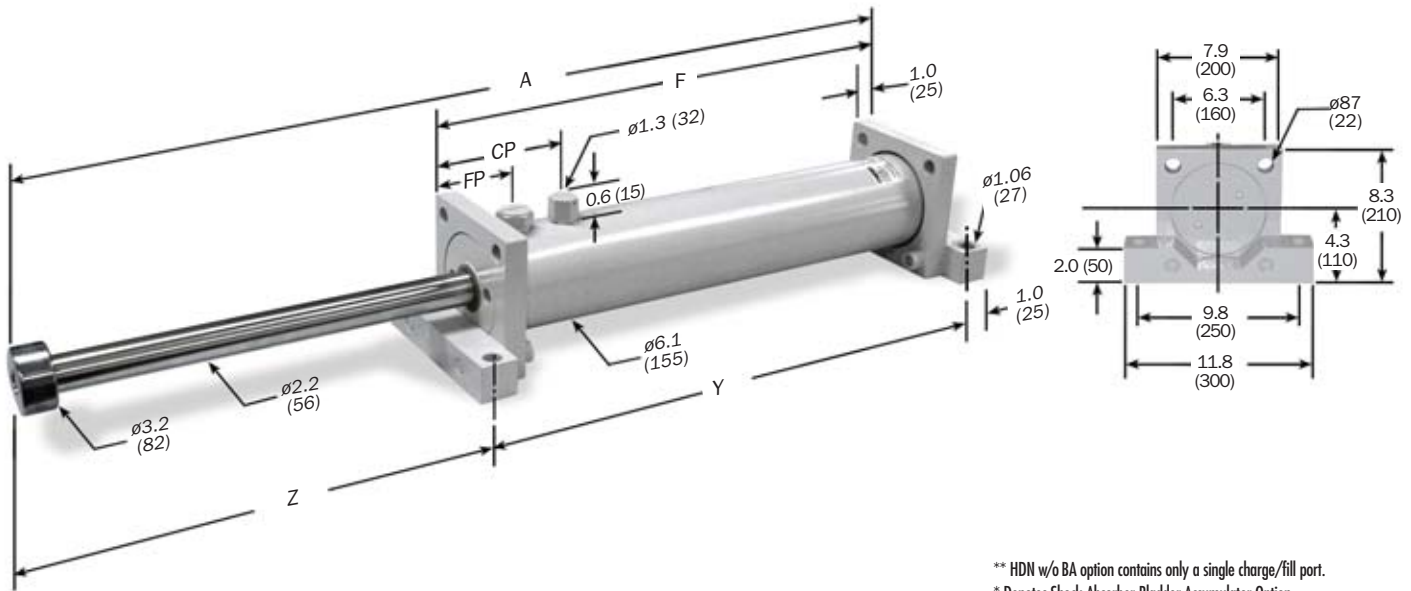

Dimensions are in inches (millimeters).

** HDN w/o BA option contains only a single charge/fill port.
 * Denotes Shock Absorber Bladder Accumulator Option.
 Note: For TF, FF and FR mounting, delete front foot and dimensions.

Catalog No./ Model	(S) Stroke in. (mm)	(E ₁) Max. in.-lbs./cycle (Nm/cycle)	(E ₂) Max. in.-lbs./hour (Nm/hr)	(F _p) Max. Shock Force lbs. (N)	Nominal Return Force BA* lbs. (N)	Nominal Return Force w/o BA* lbs. (N)	A in. (mm)	F in. (mm)	Y in. (mm)	Z in. (mm)	With BA		CP** w/o BA* in. (mm)	Model Weight lbs. (Kg)
											CP BA* in. (mm)	FP BA* in. (mm)		
HDN 3.5 x 2	2 (50)	115,200 (13 000)	6,912,100 (781 000)	67,500 (300 250)	215 (960)	455 (2 020)	13.9 (354)	9.6 (244)	11.6 (294)	3.3 (85)	5.3 (134)	3.0 (77)	2.1 (52)	73 (33)
HDN 3.5 x 4	4 (100)	230,400 (26 000)	8,793,200 (993 500)	67,500 (300 250)	230 (1 020)	610 (2 710)	18.0 (456)	11.6 (295)	13.6 (345)	5.4 (136)	5.3 (134)	3.0 (77)	2.1 (52)	82 (37)
HDN 3.5 x 6	6 (150)	343,300 (38 800)	10,283,600 (1 161 900)	67,500 (300 250)	260 (1 160)	1,010 (4 480)	21.9 (556)	13.6 (345)	15.6 (395)	7.3 (186)	5.3 (134)	3.0 (77)	2.1 (52)	90 (41)
HDN 3.5 x 8	8 (200)	450,300 (50 900)	11,803,800 (1 333 600)	67,500 (300 250)	265 (1 180)	1,010 (4 480)	25.9 (658)	15.6 (396)	17.6 (446)	9.3 (237)	5.3 (134)	3.0 (77)	2.1 (52)	99 (45)
HDN 3.5 x 10	10 (250)	538,400 (60 800)	13,324,000 (1 505 400)	67,500 (300 250)	270 (1 200)	1,010 (4 480)	29.9 (760)	17.6 (447)	19.6 (497)	11.3 (288)	5.3 (134)	3.0 (77)	2.1 (52)	108 (49)
HDN 3.5 x 12	12 (300)	626,500 (70 800)	14,844,100 (1 677 200)	67,500 (300 250)	270 (1 200)	1,010 (4 480)	33.9 (862)	19.6 (498)	21.6 (548)	13.3 (339)	5.3 (134)	3.0 (77)	2.1 (52)	117 (53)
HDN 3.5 x 16	16 (400)	801,000 (90 500)	17,854,700 (2 017 300)	67,500 (300 250)	275 (1 225)	1,010 (4 480)	41.9 (1 064)	23.6 (599)	25.6 (649)	17.3 (440)	5.3 (134)	3.0 (77)	2.1 (52)	132 (60)
HDN 3.5 x 20	20 (500)	1,051,800 (118 800)	22,534,500 (2 546 100)	67,500 (300 250)	275 (1 225)	1,010 (4 480)	52.0 (1 323)	29.8 (756)	31.8 (806)	21.2 (542)	7.4 (189)	5.2 (132)	2.1 (52)	163 (74)
HDN 3.5 x 24	24 (600)	1,228,000 (138 700)	25,574,800 (2 889 600)	67,500 (300 250)	280 (1 250)	1,010 (4 480)	60.1 (1 527)	33.8 (858)	35.8 (908)	25.3 (644)	7.4 (189)	5.2 (132)	2.1 (52)	179 (81)
HDN 3.5 x 28	28 (700)	1,402,500 (158 500)	28,585,400 (3 229 700)	67,500 (300 250)	280 (1 250)	1,010 (4 480)	68.0 (1 729)	37.8 (959)	39.8 (1 009)	29.2 (745)	7.4 (189)	5.2 (132)	2.1 (52)	196 (89)
HDN 3.5 x 32	32 (800)	1,578,700 (178 400)	31,625,800 (3 573 200)	67,500 (300 250)	280 (1 250)	1,010 (4 480)	76.1 (1 933)	41.8 (1 061)	43.8 (1 111)	33.2 (847)	7.4 (189)	5.2 (132)	2.1 (52)	214 (97)
HDN 3.5 x 36	36 (900)	1,754,900 (198 300)	34,666,100 (3 916 800)	58,500 (260 200)	280 (1 250)	1,010 (4 480)	84.1 (2 137)	45.8 (1 163)	47.8 (1 213)	37.3 (949)	7.4 (189)	5.2 (132)	2.1 (52)	231 (105)
HDN 3.5 x 40	40 (1 000)	1,918,600 (216 800)	37,676,700 (4 256 900)	48,500 (215 700)	280 (1 250)	1,010 (4 480)	92.1 (2 339)	49.8 (1 264)	51.8 (1 314)	41.3 (1 050)	7.4 (189)	5.2 (132)	2.1 (52)	247 (112)
HDN 3.5 x 48	48 (1 200)	2,188,000 (247 200)	43,638,200 (4 930 500)	35,000 (155 700)	280 (1 250)	1,010 (4 480)	107.8 (2 739)	57.6 (1 464)	59.6 (1 514)	49.2 (1 250)	7.4 (189)	5.2 (132)	2.1 (52)	282 (128)
HDN 3.5 x 56	56 (1 400)	2,418,600 (273 300)	49,599,700 (5 604 000)	25,300 (112 500)	470 (2 100)	1,010 (4 480)	107.8 (2 739)	57.6 (1 464)	59.6 (1 514)	49.2 (1 250)	7.4/35.7** (189/908)	5.2 (132)	2.1 (52)	282 (128)

- Notes: 1. HDN shock absorbers will function satisfactorily at 5% of their maximum rated energy per cycle. If less than these values, a smaller model should be specified.
- 2. It is recommended that the customer consult ITT Enidine for safety-related overhead crane applications.
- 3. The energy data listed is for ideal linear impacts only. If side load conditions exist in the application, contact ITT Enidine for sizing assistance.
- 4. Rear flange mounting of 12 inch (300 mm) strokes and longer not recommended. Front and rear flange or foot mount configurations are recommended.
- 5. Maximum cycle rate is 60 cycles/hr. for HDN with BA option and 30 cycles/hr. without BA option.
- 6. For impact velocities over 180 in./sec. (4.5 m/s), consult factory.
- 7. ** HDN 3.5 x 56 has two charge ports.

Heavy Duty Series Shock Absorber

HDN 4.0 Series

Technical Data

HDN 4.0 x 2 → HDN 4.0 x 48 Series

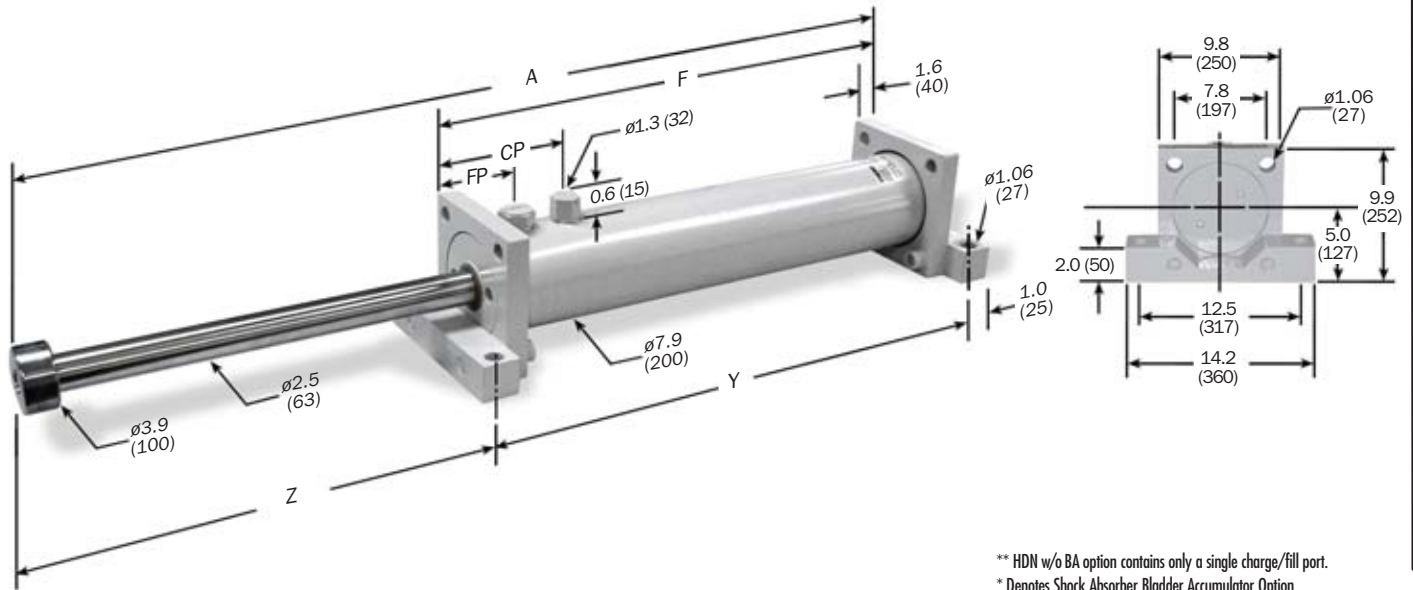

Dimensions are in inches (millimeters).

** HDN w/o BA option contains only a single charge/fill port.
* Denotes Shock Absorber Bladder Accumulator Option.
Note: For TF, FF and FR mounting, delete front foot and dimensions.

Catalog No./ Model	(S) Stroke in. (mm)	(E _T) Max. in.-lbs./cycle (Nm/cycle)	(E _T C) Max. in.-lbs./hour (Nm/hr)	(F _P) Max. Initial Shock Force lbs. (N)	Nominal Return Force BA* lbs. (N)	Nominal Return Force w/o BA* lbs. (N)	A in. (mm)	F in. (mm)	Y in. (mm)	Z in. (mm)	With BA		CP** w/o BA* in. (mm)	Model Weight lbs. (Kg)
											CP BA* in. (mm)	FP BA* in. (mm)		
HDN 4.0 x 2	2 (50)	139,200 (15 700)	8,352,800 (943 700)	80,000 (355 900)	250 (1 100)	425 (1 900)	16.9 (430)	11.6 (294)	13.5 (344)	4.4 (111)	8.1 (206)	4.3 (108)	2.5 (64)	141 (64)
HDN 4.0 x 4	4 (100)	275,700 (31 200)	13,579,600 (1 534 300)	80,000 (355 900)	270 (1 200)	485 (2 160)	20.9 (532)	13.6 (345)	15.6 (395)	6.4 (162)	8.1 (206)	4.3 (108)	2.5 (64)	154 (70)
HDN 4.0 x 6	6 (150)	409,606 (46 279)	15,547,700 (1 756 700)	80,000 (355 900)	270 (1 200)	690 (3 050)	24.9 (632)	15.6 (395)	17.5 (445)	8.3 (212)	8.1 (206)	4.3 (108)	2.5 (64)	168 (76)
HDN 4.0 x 8	8 (200)	548,800 (62 000)	17,594,400 (1 987 900)	80,000 (355 900)	270 (1 200)	980 (4 370)	28.9 (735)	17.6 (447)	19.6 (497)	10.4 (263)	8.1 (206)	4.3 (108)	2.5 (64)	181 (82)
HDN 4.0 x 10	10 (250)	682,700 (77,100)	19,562,500 (2 210 300)	80,000 (355 900)	270 (1 200)	1,230 (5 465)	32.9 (836)	19.6 (497)	21.5 (547)	12.4 (314)	8.1 (206)	4.3 (108)	2.5 (64)	192 (87)
HDN 4.0 x 12	12 (300)	819,200 (92 600)	25,269,900 (1 855 100)	80,000 (355 900)	275 (1 225)	1,000 (4 440)	40.6 (1 032)	25.3 (642)	27.2 (692)	14.4 (365)	11.8 (300)	8.0 (202)	2.5 (64)	238 (108)
HDN 4.0 x 16	16 (400)	1,089,600 (123,100)	29,245,400 (3 304 300)	80,000 (355 900)	275 (1 225)	1,270 (5 650)	48.6 (1 234)	29.3 (743)	31.2 (793)	18.3 (466)	11.8 (300)	8.0 (202)	2.5 (64)	265 (120)
HDN 4.0 x 20	20 (500)	1,362,700 (154 000)	33,260,200 (3 757 900)	80,000 (355 900)	280 (1 245)	1,155 (5 145)	56.6 (1 438)	33.3 (845)	35.2 (895)	22.4 (568)	11.8 (300)	8.0 (202)	2.5 (64)	290 (131)
HDN 4.0 x 24	24 (600)	1,635,700 (184 800)	37,275,000 (4 211 500)	80,000 (355 900)	280 (1 245)	1,275 (5 675)	64.6 (1 642)	37.3 (947)	39.3 (997)	26.4 (670)	11.8 (300)	8.0 (202)	2.5 (64)	317 (144)
HDN 4.0 x 28	28 (700)	1,904,200 (215 100)	41,250,500 (4 660 700)	80,000 (355 900)	280 (1 245)	1,275 (5 675)	72.6 (1 844)	41.3 (1 048)	43.2 (1 098)	30.4 (771)	11.8 (300)	8.0 (202)	2.5 (64)	346 (157)
HDN 4.0 x 32	32 (800)	2,128,700 (240 500)	45,265,400 (5 114 300)	80,000 (355 900)	280 (1 245)	1,275 (5 675)	80.6 (2 048)	45.3 (1 150)	47.2 (1 200)	34.4 (873)	11.8 (300)	8.0 (202)	2.5 (64)	375 (170)
HDN 4.0 x 36	36 (900)	2,353,200 (265 900)	49,280,200 (5 567 900)	80,000 (355 900)	280 (1 245)	1,275 (5 675)	88.7 (2 252)	49.3 (1 252)	51.3 (1 302)	38.4 (975)	11.8 (300)	8.0 (202)	2.5 (64)	403 (183)
HDN 4.0 x 40	40 (1 000)	2,566,000 (289 900)	53,255,700 (6 017 100)	80,000 (355 900)	280 (1 245)	1,275 (5 675)	96.6 (2 454)	53.3 (1 353)	55.2 (1 403)	42.4 (1 076)	11.8 (300)	8.0 (202)	2.5 (64)	430 (195)
HDN 4.0 x 48	48 (1 200)	2,914,200 (329 300)	61,246,000 (6 919 900)	45,000 (200 000)	280 (1 245)	1,275 (5 675)	112.4 (2 854)	61.3 (1 556)	63.2 (1 606)	50.1 (1 273)	11.8 (300)	8.0 (202)	2.5 (64)	485 (220)

- Notes: 1. HDN shock absorbers will function satisfactorily at 5% of their maximum rated energy per cycle. If less than these values, a smaller model should be specified.
2. It is recommended that the customer consult ITT Enidine for safety-related overhead crane applications.
3. The energy data listed is for ideal linear impacts only. If side load conditions exist in the application, contact ITT Enidine for sizing assistance.
4. Rear flange mounting of 12 inch (300 mm) strokes and longer not recommended. Front and rear flange or foot mount configurations are recommended.
5. Maximum cycle rate is 60 cycles/hr. for HDN with BA option and 30 cycles/hr. without BA option.
6. For impact velocities over 180 in./sec. (4.5 m/s), consult factory.

HDA 3.0 x 2 → HDA 3.0 x 12 Series

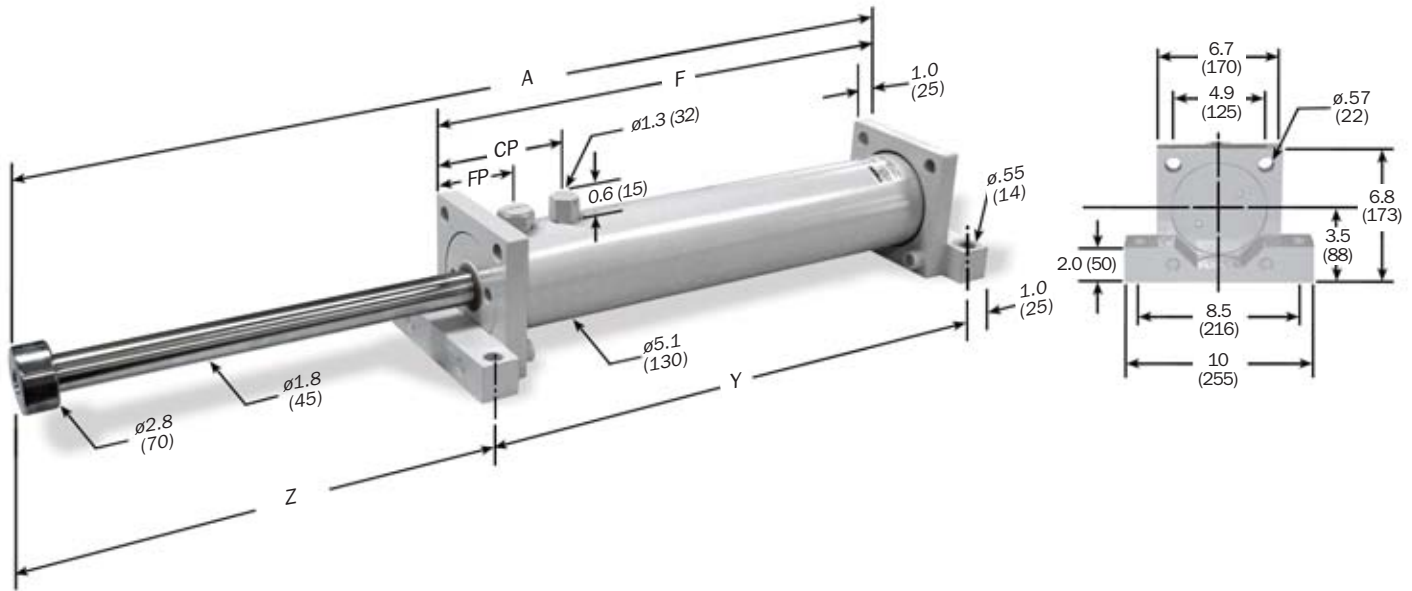

Dimensions are in inches (millimeters).

Note: For TF, FF and FR mounting, delete front foot and dimensions.

Catalog No./ Model	(S) Stroke in. (mm)	(E _T) Max. in.-lbs./cycle (Nm/cycle)	(E _C) Max. in.-lbs./hour (Nm/hr)	(F _p) Max. End Shock Force lbs. (N)	Nominal Return Force BA* lbs. (N)	A in. (mm)	F in. (mm)	Y in. (mm)	Z in. (mm)	With BA		Model Weight lbs. (Kg)
										CP* in. (mm)	FP* in. (mm)	
HDA 3.0 x 2	2 (50)	40,000 (4 500)	2,400,000 (271 200)	50,000 (222 400)	150 (660)	13.2 (336)	8.4 (213)	10.4 (263)	3.9 (98)	4.4 (112)	2.4 (61)	40 (21)
HDA 3.0 x 3	3 (75)	60,000 (6 800)	3,600,000 (406 700)	50,000 (222 400)	160 (710)	15.2 (387)	9.4 (239)	11.4 (289)	4.8 (123)	4.4 (112)	2.4 (61)	42 (22)
HDA 3.0 x 5	5 (125)	100,000 (11 300)	6,000,000 (677 900)	50,000 (222 400)	165 (730)	19.3 (489)	11.4 (290)	13.4 (340)	6.9 (174)	4.4 (112)	2.4 (61)	48 (25)
HDA 3.0 x 8	8 (200)	160,000 (18 100)	9,296,000 (1 050 300)	50,000 (222 400)	170 (765)	25.2 (640)	14.4 (365)	16.3 (415)	9.8 (250)	4.4 (112)	2.4 (61)	57 (29)
HDA 3.0 x 10	10 (250)	200,000 (22 600)	10,594,500 (1 197 100)	50,000 (222 400)	175 (775)	29.2 (742)	16.4 (416)	18.3 (466)	11.9 (301)	4.4 (112)	2.4 (61)	64 (32)
HDA 3.0 x 12	12 (300)	240,000 (27 200)	11,893,800 (1 343 800)	50,000 (222 400)	175 (775)	33.2 (844)	18.4 (467)	20.4 (517)	13.8 (352)	4.4 (112)	2.4 (61)	71 (35)

- Notes: 1. HDA shock absorbers will function satisfactorily at 5% of their maximum rated energy per cycle. If less than these values, a smaller model should be specified.
 2. It is recommended that the customer consult ITT Enidine for safety-related overhead crane applications.
 3. The energy data listed is for ideal linear impacts only. If side load conditions exist in the application, contact ITT Enidine for sizing assistance.
 4. Rear flange mounting of 12 inch (300 mm) strokes and longer not recommended. Front and rear flange or foot mount configurations are recommended.
 5. Maximum cycle rate is 60 cycles/hr.
 6. HDA models which have an impact velocity below 30 in./sec. (.8 m/sec.), please contact ITT Enidine for assistance.
 7. Maximum allowable applied propelling force: 25,000 lbs. (111 200 N)

Adjustment Techniques

Useable Adjustment Setting Range

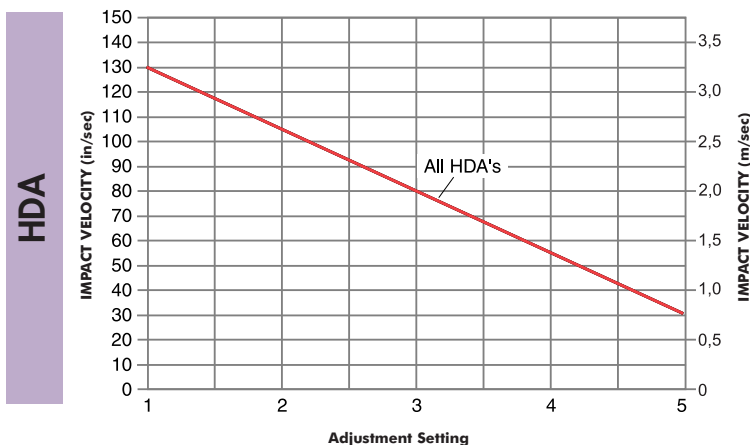

After properly sizing an HDA shock absorber, the useable range of adjustment settings can be determined:

1. Locate the intersection point of the application's impact velocity and the HDA model graph line.
2. The intersection is the maximum adjustment setting to be used. Adjustments exceeding this setting could overload the shock absorber.
3. The useable adjustment setting range is from setting 1 to the MAXIMUM adjustment setting as determined in step 2.

EXAMPLE: HDA Series

1. Impact Velocity: 80 in./sec. (2 m/s)
2. Intersection Point: Adjustment Setting 3
3. Useable Adjustment Setting Range: 1 to 3

Heavy Duty Adjustable Series Shock Absorber

HDA 4.0 Series

Technical Data

HDA 4.0 x 2 → HDA 4.0 x 10 Series

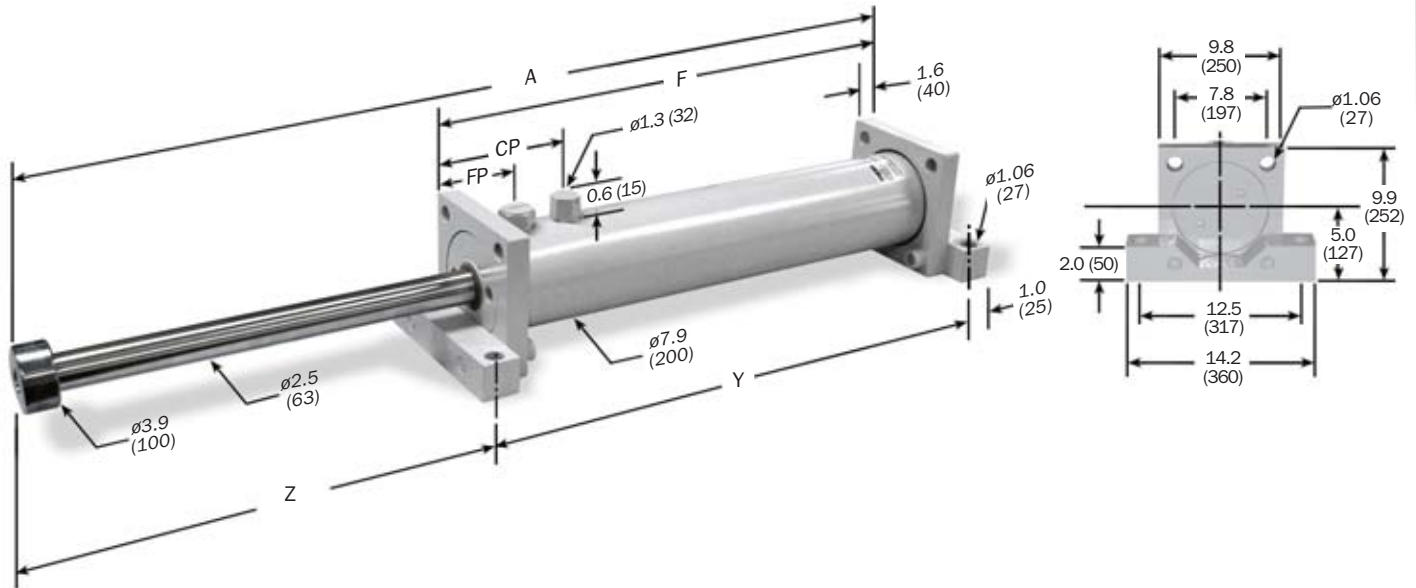

Dimensions are in inches (millimeters).

Note: For TF, FF and FR mounting, delete front foot and dimensions.

Catalog No./ Model	(S) Stroke in. (mm)	(E _T) Max. in.-lbs./cycle (Nm/cycle)	(E _T -C) Max. in.-lbs./hour (Nm/hr)	(F _P) Max. End Shock Force lbs. (N)	Nominal Return Force BA* lbs. (N)	A in. (mm)	F in. (mm)	Y in. (mm)	Z in. (mm)	With BA		Model Weight lbs. (Kg)
										CP* in. (mm)	FP* in. (mm)	
HDA 4.0 x 2	2 (50)	120,000 (13 600)	7,200,000 (813 500)	80,000 (355 900)	250 (1 125)	16.9 (430)	12.0 (304)	13.9 (354)	4.0 (101)	7.1 (180)	4.3 (108)	141 (64)
HDA 4.0 x 4	4 (100)	240,000 (27 100)	13,973,200 (1 578 800)	80,000 (355 900)	250 (1 125)	20.9 (532)	14.0 (355)	15.9 (405)	6.0 (152)	7.1 (180)	4.3 (108)	154 (70)
HDA 4.0 x 6	6 (150)	360,000 (40 700)	15,941,300 (1 801 100)	80,000 (355 900)	250 (1 125)	24.9 (632)	15.9 (405)	17.9 (455)	8.0 (202)	7.1 (180)	4.3 (108)	168 (76)
HDA 4.0 x 8	8 (200)	480,000 (54 200)	17,988,100 (2 032 400)	80,000 (355 900)	250 (1 125)	28.9 (735)	18.0 (457)	20.0 (507)	10.0 (253)	7.1 (180)	4.3 (108)	181 (82)
HDA 4.0 x 10	10 (250)	600,000 (67 800)	19,956,100 (2 254 700)	80,000 (355 900)	250 (1 125)	32.9 (836)	20.0 (507)	21.9 (557)	12.0 (304)	7.1 (180)	4.3 (108)	192 (87)

- Notes: 1. HDA shock absorbers will function satisfactorily at 5% of their maximum rated energy per cycle. If less than these values, a smaller model should be specified.
 2. It is recommended that the customer consult ITT Enidine for safety-related overhead crane applications.
 3. The energy data listed is for ideal linear impacts only. If side load conditions exist in the application, contact ITT Enidine for sizing assistance.
 4. Rear flange mounting of 12 inch (300 mm) strokes and longer not recommended. Front and rear flange or foot mount configurations are recommended.
 5. Maximum cycle rate is 60 cycles/hr.
 6. HDA models which have an impact velocity below 30 in./sec. (.8 m/sec.), please contact ITT Enidine for assistance.
 7. Maximum allowable applied propelling force: 40,000 (177 900 N)

Damping Force

Position 1 provides minimum damping force.
 Position 5 provides maximum damping force.

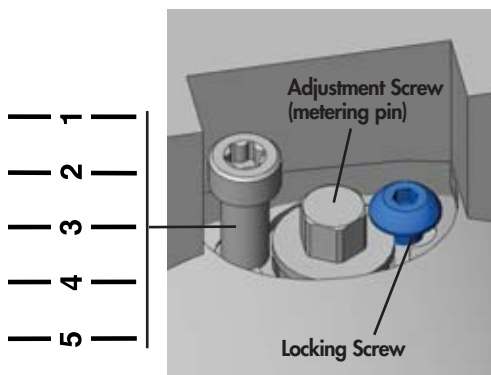

Adjustment Technique

1. Loosen button head lock screw.
2. Set adjustment screw to desired setting.
3. Tighten button head lock screw on shoulder of adjustment screw.

HD Series

Custom-orificed design accommodates specified damping requirements. Computer generated output performance simulation is used to optimize the orifice configuration. Available in standard bore dimensions of up to 5 in. (125mm) and 6 in. (156mm) with strokes over 60 in. (1525mm).



Features and Benefits HD

- Compact design smoothly and safely decelerates large energy capacity loads up to 8,000,000 in.-lbs. per cycle (900 000 Nm)
- Engineered to meet OSHA, AISE, CMAA and other safety specifications such as DIN and FEM.
- Internal air charged bladder accumulator replaces mechanical return springs, providing shorter overall length and reduced weight.
- Wide variety of optional configurations including bellows, clevis mounts and safety cables.
- Available in standard adjustable or custom-orificed non-adjustable models.
- Zinc plated external components provide enhanced corrosion protection.
- Epoxy painting and special rod materials are available for use in highly corrosive environments.
- All sizes are fully field repairable.
- Piston rod extension sensor systems available for reuse safety requirements.
- Incorporating optional fluids and seal packages can expand standard operating temperature range from 15°F to 140°F to -30°F to 210°F (-10°C to 60°C) to (-35°C to 100°C)

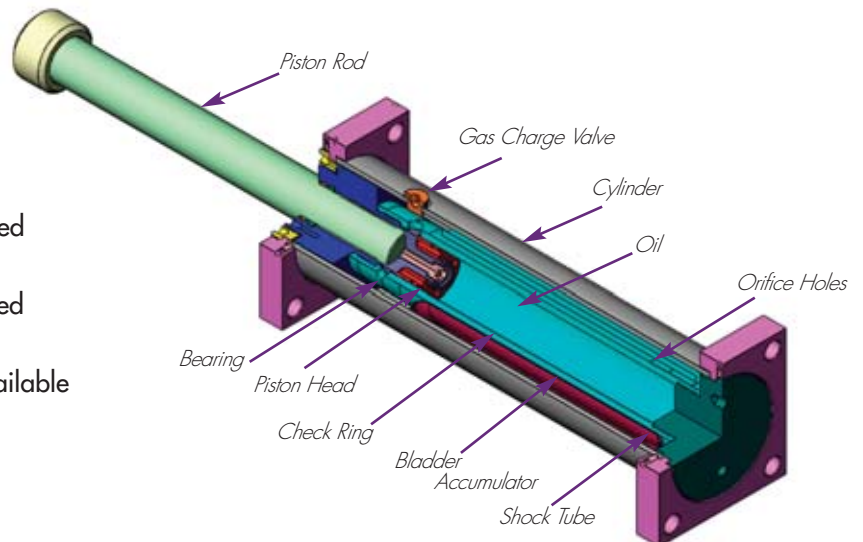

Heavy Duty Series Shock Absorber

HD 5.0 Series

Technical Data

HD 5.0 x 4 → HD 5.0 x 48 Series

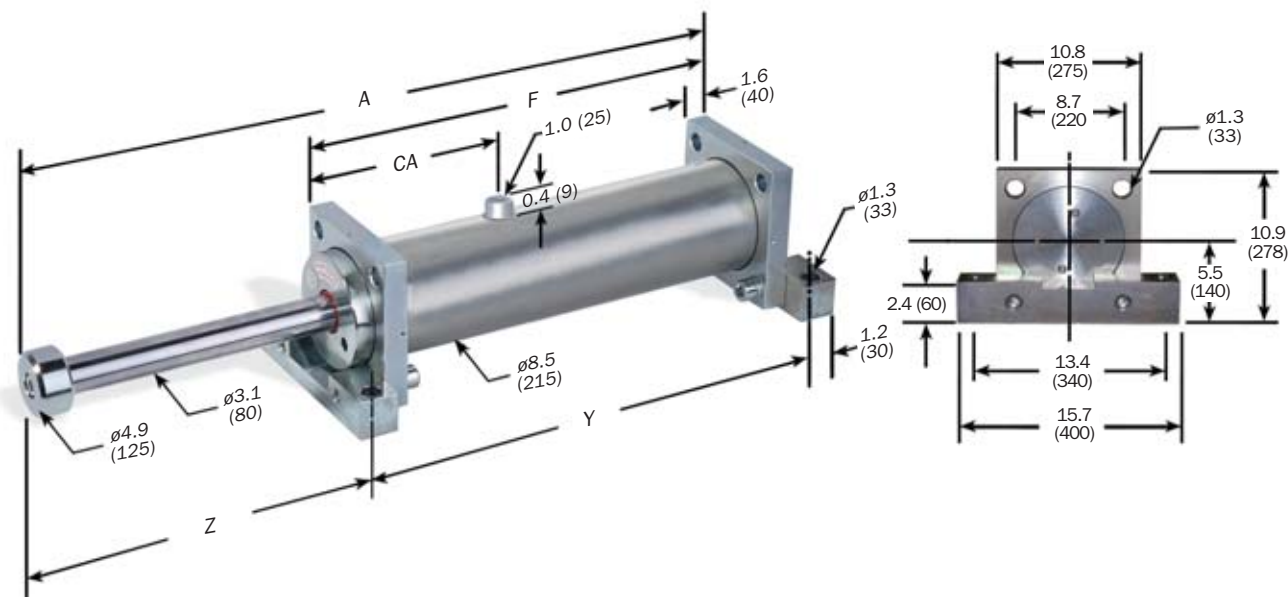

Dimensions are in inches (millimeters).

Note: For TF, FF and FR mounting, delete front foot and dimensions.

Catalog No./ Model	(S) Stroke in. (mm)	(E _T) Max. in.-lbs./cycle (Nm/cycle)	(E _T C) Max. in.-lbs./hour (Nm/hr)	(F _P) Max. Shock Force lbs. (N)	Nominal Return Force BA* lbs. (N)	A in. (mm)	F in. (mm)	Y in. (mm)	Z in. (mm)	CA in. (mm)	Model Weight lbs. (Kg)
HD 5.0 x 4	4 (100)	414,000 (46 700)	16,000,000 (1 762 621)	124,000 (550 000)	400 (1 760)	23.3 (591)	14.8 (37.5)	17.1 (435)	7.4 (186)	9.1 (230)	192 (87)
HD 5.0 x 6	6 (150)	620,000 (70 000)	17,720,000 (2 002 337)	124,000 (550 000)	400 (1 760)	27.3 (693)	16.8 (426)	19.1 (486)	9.4 (237)	9.1 (230)	207 (94)
HD 5.0 x 8	8 (200)	828,000 (93 500)	19,841,000 (2 242 053)	124,000 (550 000)	400 (1 760)	31.3 (795)	18.8 (477)	21.1 (537)	11.4 (288)	9.1 (230)	223 (101)
HD 5.0 x 10	10 (250)	1,036,000 (117 000)	21,921,000 (2 477 070)	124,000 (550 000)	400 (1 760)	35.3 (895)	20.8 (527)	23.1 (587)	13.4 (338)	9.1 (230)	238 (108)
HD 5.0 x 12	12 (300)	1,239,000 (140 000)	24,042,000 (2 716 786)	124,000 (550 000)	400 (1 760)	39.3 (997)	22.8 (578)	25.1 (638)	15.4 (389)	9.1 (230)	251 (114)
HD 5.0 x 16	16 (400)	1,655,000 (187 000)	28,285,000 (3 196 219)	124,000 (550 000)	400 (1 760)	47.3 (1 201)	26.8 (680)	29.1 (740)	19.4 (491)	9.1 (230)	282 (128)
HD 5.0 x 20	20 (500)	2,071,000 (234 000)	36,688,000 (4 145 684)	124,000 (550 000)	400 (1 760)	59.2 (1 504)	34.7 (882)	37.1 (942)	23.3 (592)	13.0 (230)	348 (158)
HD 5.0 x 24	24 (600)	2,478,000 (280 000)	40,930,000 (4 625 117)	124,000 (550 000)	400 (1 760)	67.2 (1 708)	38.7 (984)	41.1 (1 044)	27.3 (694)	13.0 (230)	377 (171)
HD 5.0 x 28	28 (700)	2,894,000 (327 000)	45,132,000 (5 099 849)	124,000 (550 000)	400 (1 760)	75.2 (1 910)	42.7 (1 085)	45.1 (1 145)	31.3 (795)	13.0 (230)	407 (185)
HD 5.0 x 32	32 (800)	3,310,000 (374 000)	49,374,000 (5 579 282)	124,000 (550 000)	400 (1 760)	83.2 (2 114)	46.7 (1 187)	49.1 (1 247)	35.3 (897)	13.0 (230)	437 (198)
HD 5.0 x 40	40 (1 000)	4,133,000 (467 000)	57,818,000 (6 533 447)	124,000 (550 000)	400 (1 760)	99.2 (2 520)	54.7 (1 390)	57.1 (1 450)	43.3 (1 100)	13.0 (231)	496 (225)
HD 5.0 x 48	48 (1 200)	4,750,000 (535 800)	66,262,000 (7 487 613)	92,000 (410 000)	400 (1 760)	115.0 (2 920)	62.6 (1 590)	65.0 (1 650)	51.6 (1 300)	13.0 (230)	534 (242)

Notes: 1. HD shock absorbers will function satisfactorily at 5% of their maximum rated energy per cycle.

HDA models will function satisfactorily at 10% of their maximum rated energy per cycle. If less than these values, a smaller model should be specified.

2. It is recommended that the customer consult ITT Endine for safety-related overhead crane applications.

3. The energy data listed is for ideal linear impacts only. If side load conditions exist in the application, contact ITT Endine for sizing assistance.

4. Rear flange mounting of 12 inch (300 mm) strokes and longer not recommended. Front and rear flange or foot mount configurations are recommended.

5. Maximum cycle rate is 60 cycles/hr.

6. For impact velocities over 180 in./sec. (4.5 m/s), consult factory.

HD 6.0 x 4 → HD 6.0 x 48 Series

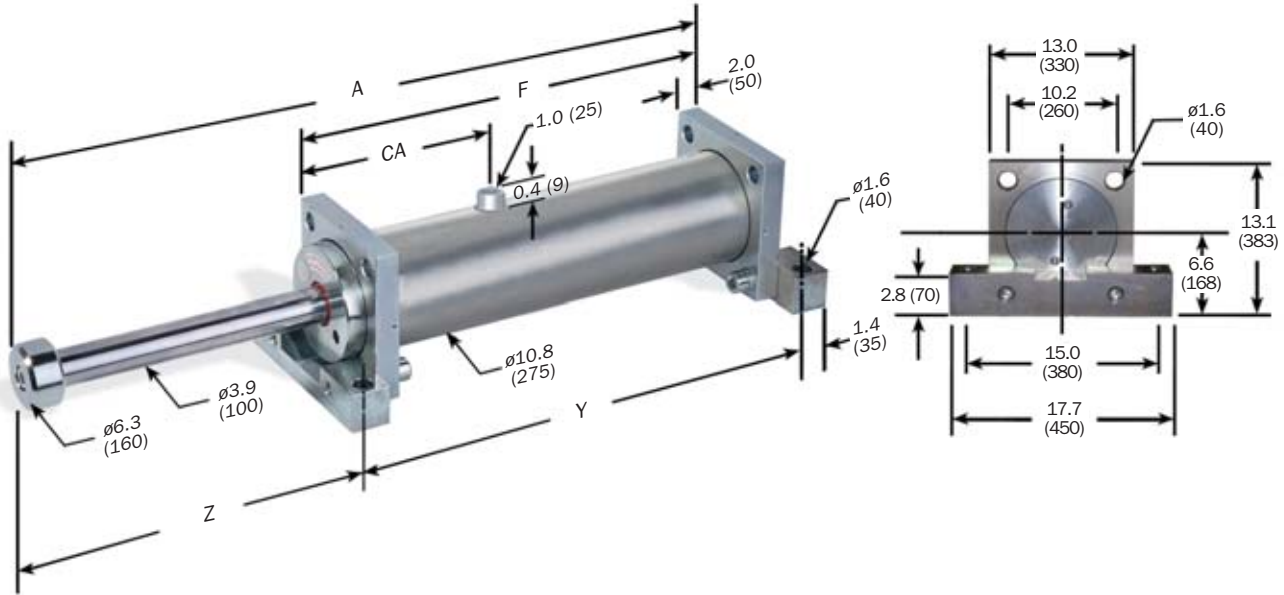

Dimensions are in inches (millimeters).

Note: For TF, FF and FR mounting, delete front foot and dimensions.

Catalog No./ Model	(S) Stroke in. (mm)	(E _T) Max. in.-lbs./cycle (Nm/cycle)	(E _{T-C}) Max. in.-lbs./hour (Nm/hr)	(F _P) Max. Shock Force lbs. (N)	Nominal Return Force BA* lbs. (N)	A in. (mm)	F in. (mm)	Y in. (mm)	Z in. (mm)	CA in. (mm)	Model Weight lbs. (Kg)
HD(A) 6.0 x 4	4 (100)	677,000 (76 500)	21,280,000 (2 404 568)	202,250 (900 000)	625 (2 750)	25.1 (637)	15.4 (391)	18.2 (461)	8.3 (211)	7.8 (197)	362 (164)
HD(A) 6.0 x 6	6 (150)	1,010,000 (114 000)	23,933,000 (2 704 389)	202,250 (900 000)	625 (2 750)	29.1 (737)	17.4 (441)	20.2 (511)	10.3 (261)	7.8 (197)	386 (175)
HD(A) 6.0 x 8	8 (200)	1,354,000 (153 000)	26,586,000 (3 004 211)	202,250 (900 000)	625 (2 750)	33.1 (839)	19.4 (492)	22.2 (562)	12.3 (312)	7.8 (197)	410 (186)
HD(A) 6.0 x 10	10 (250)	1,690,000 (191 000)	29,345,000 (3 316 025)	202,250 (900 000)	625 (2 750)	37.1 (941)	21.4 (543)	24.2 (613)	14.3 (363)	7.8 (197)	432 (196)
HD(A) 6.0 x 12	12 (300)	1,982,000 (224 000)	32,052,000 (3 621 843)	202,250 (900 000)	625 (2 750)	41.1 (1 043)	23.4 (594)	26.2 (664)	16.3 (414)	7.8 (197)	456 (207)
HD 6.0 x 16	16 (400)	2,708,000 (306 000)	37,465,000 (4 233 478)	202,250 (900 000)	625 (2 750)	49.1 (1 246)	27.4 (696)	30.2 (766)	20.3 (515)	7.8 (197)	503 (228)
HD 6.0 x 20	20 (500)	3,380,000 (382 000)	42,877,000 (4 845 114)	202,250 (900 000)	625 (2 750)	57.1 (1 450)	31.4 (798)	34.2 (868)	24.3 (617)	7.8 (197)	551 (250)
HD 6.0 x 24	24 (600)	4,062,000 (459 000)	53,862,000 (6 086 375)	202,250 (900 000)	625 (2 750)	69.7 (1 769)	40.0 (1 015)	42.7 (1 085)	28.4 (719)	12.3 (312)	681 (309)
HD 6.0 x 30	30 (750)	5,070,000 (573 000)	61,928,000 (6 997 832)	202,250 (900 000)	625 (2 750)	81.6 (2 073)	46.0 (1 167)	48.7 (1 237)	34.3 (871)	12.3 (312)	752 (341)
HD 6.0 x 36	36 (900)	6,093,000 (688 500)	70,047,000 (7 915 285)	202,250 (900 000)	625 (2 750)	93.7 (2 379)	52.0 (1 320)	54.7 (1 390)	40.4 (1 024)	12.3 (312)	822 (373)
HD 6.0 X 42	42 (1 050)	7,106,000 (803 000)	78,113,000 (8 826 743)	202,250 (900 000)	625 (2 750)	105.6 (2 683)	58.0 (1 472)	60.7 (1 542)	46.3 (1 176)	12.3 (312)	893 (405)
HD 6.0 x 48	48 (1 200)	8,000,000 (898 200)	86,232,000 (9 744 196)	178,00 (790 000)	625 (2 750)	117.7 (2 989)	64.0 (1 625)	66.7 (1 695)	52.4 (1 329)	12.3 (312)	966 (438)

Notes: 1. HD shock absorbers will function satisfactorily at 5% of their maximum rated energy per cycle.

HDA models will function satisfactorily at 10% of their maximum rated energy per cycle. If less than these values, a smaller model should be specified.

- It is recommended that the customer consult ITT Enidine for safety-related overhead crane applications.
- The energy data listed is for ideal linear impacts only. If side load conditions exist in the application, contact ITT Enidine for sizing assistance.
- Rear flange mounting of 12 inch (300 mm) strokes and longer not recommended. Front and rear flange or foot mount configurations are recommended.
- HDA models which have an impact velocity below 30 in./sec (.8 m/sec.), please contact ITT Enidine for sizing assistance.
- Maximum cycle rate is 60 cycles/hr.
- For impact velocities over 180 in./sec. (4.5 m/s), consult factory.

Heavy Duty Series Shock Absorber

Mounting and Accessories for HDN, HD, HDA Series

Mounting and Accessories

Typical mounting methods are shown below. Special mounting requirements can be accommodated upon request.



TM: Rear Flange Front Foot Mount



FM: Front and Rear Foot Mount
Also shown is optional safety cable, typically used in overhead applications.



TF: Front and Rear Flanges



FF: Front Flange



CM: Clevis Mount



FR: Rear Flange

Note: Rear flange mounting not recommended for stroke lengths above 12 inches. (300 mm)

HD(A) 3.0 x 2 → HD(A) 4.0 x 10 Series

Clevis Mounts (CM)

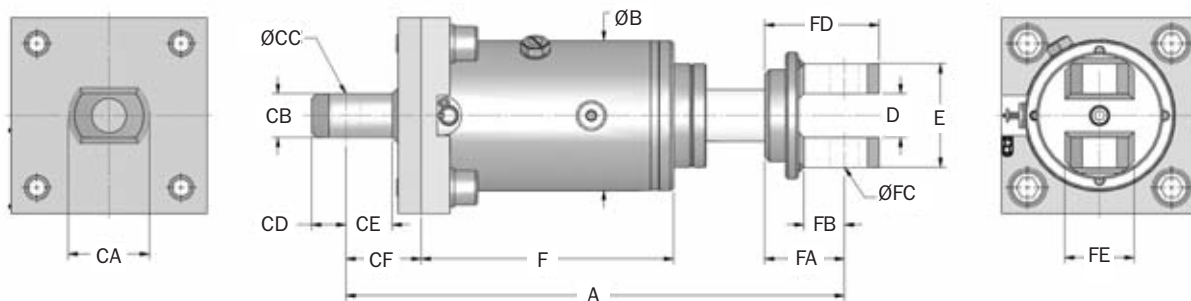

Dimensions are in inches (millimeters).

Note: Piston clevis dimensions are typical both ends on HD(A) 4.0 models.

Catalog No./ Model	Cylinder Dimensions						Cylinder Clevis Dimensions							Piston Clevis Dimensions				
	A in. (mm)	B in. (mm)	D in. (mm)	E in. (mm)	HD/HDN F in. (mm)	HDA F in. (mm)	CA in. (mm)	CB in. (mm)	CC in. (mm)	CD in. (mm)	CE in. (mm)	CF in. (mm)	FA in. (mm)	FB in. (mm)	FC in. (mm)	FD in. (mm)	FE in. (mm)	
HD(A) 3.0 x 2	17.0 (432)	5.1 (130)	1.5 (38)	3.5 (90)	8.0 (202)	9.3 (235)	2.4 (60)	1.5 (38)	1.0 (25)	1.2 (30)	1.5 (37)	2.6 (65)	2.7 (69)	1.3 (32)	1.0 (25)	3.9 (99)	2.0 (50)	
HD(A) 3.0 x 3	19.0 (483)	5.1 (130)	1.5 (38)	3.5 (90)	9.0 (229)	10.3 (261)	2.4 (60)	1.5 (38)	1.0 (25)	1.2 (30)	1.5 (37)	2.6 (65)	2.7 (69)	1.3 (32)	1.0 (25)	3.9 (99)	2.0 (50)	
HD(A) 3.0 x 5	23.0 (585)	5.1 (130)	1.5 (38)	3.5 (90)	11.0 (280)	12.3 (312)	2.4 (60)	1.5 (38)	1.0 (25)	1.2 (30)	1.5 (37)	2.6 (65)	2.7 (69)	1.3 (32)	1.0 (25)	3.9 (99)	2.0 (50)	
HD(A) 3.0 x 8	29.0 (736)	5.1 (130)	1.5 (38)	3.5 (90)	14.0 (355)	15.2 (387)	2.4 (60)	1.5 (38)	1.0 (25)	1.2 (30)	1.5 (37)	2.6 (65)	2.7 (69)	1.3 (32)	1.0 (25)	3.9 (99)	2.0 (50)	
HD(A) 3.0 x 10	33.0 (838)	5.1 (130)	1.5 (38)	3.5 (90)	16.0 (406)	17.2 (438)	2.4 (60)	1.5 (38)	1.0 (25)	1.2 (30)	1.5 (37)	2.6 (65)	2.7 (69)	1.3 (32)	1.0 (25)	3.9 (99)	2.0 (50)	
HD(A) 3.0 x 12	37.0 (940)	5.1 (130)	1.5 (38)	3.5 (90)	18.0 (457)	19.3 (489)	2.4 (60)	1.5 (38)	1.0 (25)	1.2 (30)	1.5 (37)	2.6 (65)	2.7 (69)	1.3 (32)	1.0 (25)	3.9 (99)	2.0 (50)	
HD(A) 4.0 x 2	22.4 (570)	7.9 (200)	2.6 (65)	5.5 (140)	11.6 (294)	12.0 (304)	-	-	-	-	-	3.5 (90)	3.9 (100)	2.4 (60)	2.0 (50)	5.9 (150)	3.9 (100)	
HD(A) 4.0 x 4	26.4 (672)	7.9 (200)	2.6 (65)	5.5 (140)	13.6 (345)	14.0 (355)	-	-	-	-	-	3.5 (90)	3.9 (100)	2.4 (60)	2.0 (50)	5.9 (150)	3.9 (100)	
HD(A) 4.0 x 6	30.4 (772)	7.9 (200)	2.6 (65)	5.5 (140)	15.6 (395)	15.9 (405)	-	-	-	-	-	3.5 (90)	3.9 (100)	2.4 (60)	2.0 (50)	5.9 (150)	3.9 (100)	
HD(A) 4.0 x 8	34.4 (875)	7.9 (200)	2.6 (65)	5.5 (140)	17.6 (477)	18.0 (457)	-	-	-	-	-	3.5 (90)	3.9 (100)	2.4 (60)	2.0 (50)	5.9 (150)	3.9 (100)	
HD(A) 4.0 x 10	38.4 (976)	7.9 (200)	2.6 (65)	5.5 (140)	19.6 (497)	20.0 (507)	-	-	-	-	-	3.5 (90)	3.9 (100)	2.4 (60)	2.0 (50)	5.9 (150)	3.9 (100)	

Optional Piston Rod Return Sensor

- Magnetic proximity sensor indicates complete piston rod return with 10-foot (3 m) long cable.
- If complete piston rod does not return the circuit remains open. This can be used to trigger a system shut-off.
- Contact ITT Enidine for other available sensor types.
- Sensor port in line with charge port on models HDN 1.5, 2.0 and 4.0. Location offset 90° for models HDN 3.0 and 3.5.

Sensor Specifications

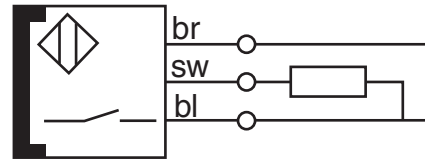

- Voltage 10 - 30V
- Load Current ≤ 200 mA
- Leakage Current ≤ 80 mA
- Load Capacitance ≤ 1.0 mF
- Ambient Temperature: -15° to 160°F (-26° to 71°C)

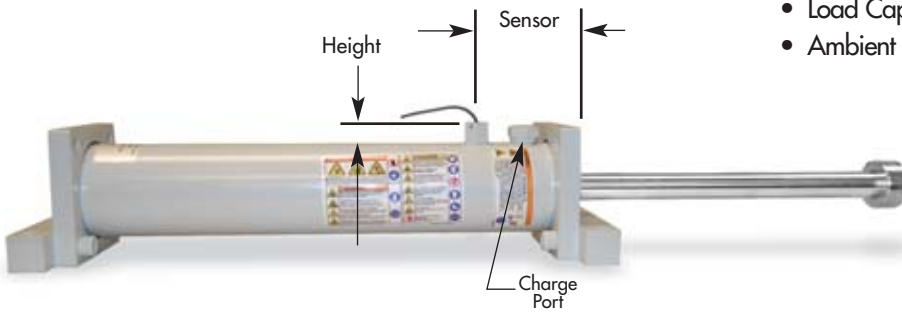

HDN 1.5, 2.0 and 4.0

Model	Sensor in. (mm)	Height in. (mm)
HDN 1.5	3.4 (86)	0.79 (20)
HDN 2.0 x 6-28	3.8 (96)	0.63 (16)
HDN 2.0 x 32-56	6.9 (176)	
HDN 4.0 x 2-10	4.3 (108)	0.35 (9)
HDN 4.0 x 12-48	8.0 (202)	

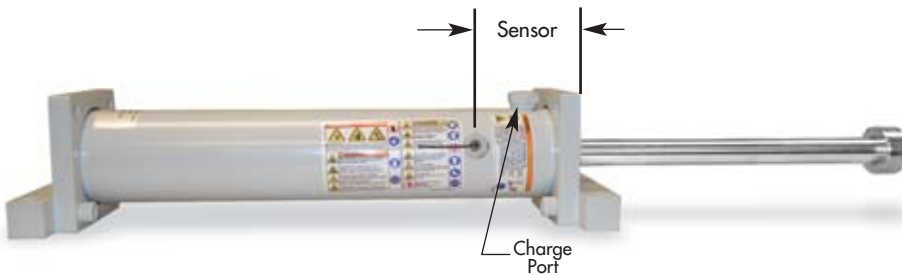

HDN 3.0 and 3.5

Model	Sensor in. (mm)	Height in. (mm)
HDN 3.0 x 2-12	2.4 (61)	0.59 (15)
HDN 3.0 x 14-32	4.4 (111)	
HDN 3.0 x 36-60	6.3 (161)	
HDN 3.5 x 2-16	3.0 (77.4)	0.35 (9)
HDN 3.5 x 20-56	5.2 (132.4)	

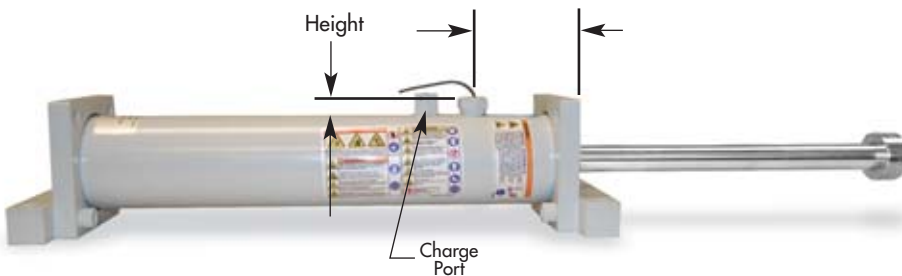

HDN 1.5, 2.0, 3.0, 3.5 and 4.0 BA

Model	Sensor in. (mm)	Height in. (mm)
HDN 1.5	3.4 (86)	0.79 (20)
HDN 2.0 x 6-28	3.8 (96)	0.63 (16)
HDN 2.0 x 32-56	6.9 (176)	
HDN 3.0 x 2-12	2.4 (61)	0.59 (15)
HDN 3.0 x 14-32	4.4 (111)	
HDN 3.0 x 36-60	6.3 (161)	
HDN 3.5 x 2-16	3.0 (77.4)	0.25 (9)
HDN 3.5 x 20-56	5.2 (132.4)	
HDN 4.0 x 2-10	4.3 (108)	0.25 (9)
HDN 4.0 x 12-48	8.0 (202)	

Urethane Cap

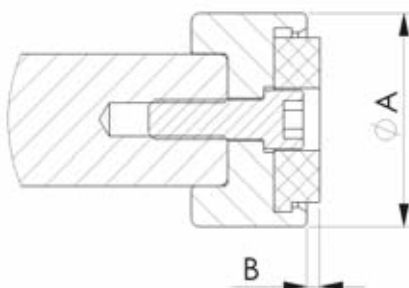

Model	Dia. A (mm)	Dia A (in.)	B (mm)	B (in.)
HDN 1.5	60	2.36	4	0.16
HDN 2.0	65	2.56	4	0.16
HDN 3.0	70	2.76	4	0.16

