



PMXT 1525/2150
Mid-Bore Series

ITT Enidine non-adjustable hydraulic shock absorbers can accommodate varying energy conditions. This family of tamperproof shock absorbers provides consistent performance, cycle after cycle. Non-adjustable models are designed to absorb maximum energy within a compact envelope size.

The **PM Series** uses a self-compensating design to provide energy absorption in low velocity and high drive force applications. The PM Series also includes the added benefit of corrosion-resistant, nickel-plated components and positive stop capabilities. Models can accommodate a wide range of operating conditions with varying masses or propelling forces.

Features and Benefits

- Extensive non-adjustable product line offers flexibility in both size and energy absorption capacity to fulfill a wide range of application requirements.
- Tamperproof design ensures repeatable performance.
- Special materials and finishes can be designed to meet specific customer requirements.
- Incorporating optional fluids and seal packages can expand the standard operating temperature range from (15°F to 180°F) to (-30°F to 210°F).
- Threaded cylinders provide mounting flexibility and increase surface area for improved heat dissipation.
- A select variety of surface finishes maintains original quality appearance and provides the longest corrosion resistance protection.
- ISO quality standards result in reliable, long-life operation.

ITT Endine Non-Adjustable Multiple Orifice Shock Absorbers

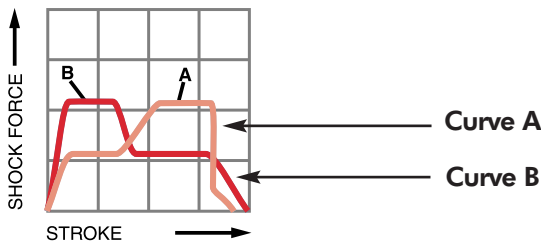
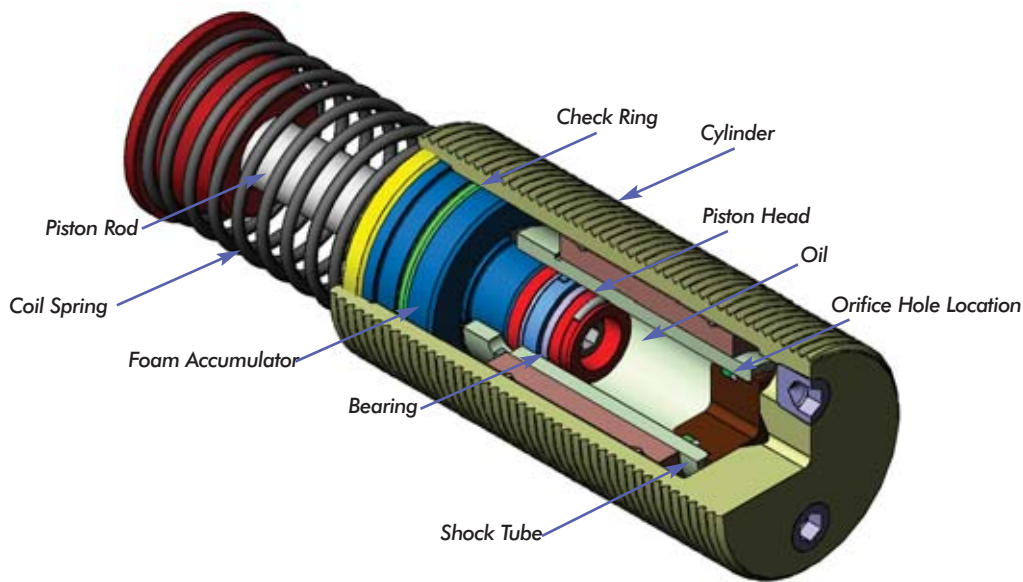

Self-compensating damping maintains acceptable deceleration with conventional type damping characteristics. Self-compensating shock absorbers operate over a wide range of weights and velocities. These shock absorbers are well suited for high drive force, low velocity applications, and where energy conditions may change. **Curve A** shows the *shock force vs. stroke* curve of a self-compensating shock absorber impacted with a low velocity and high drive force. **Curve B** shows the *shock force vs. stroke* curve of a self-compensating shock absorber impacted with a high velocity and low drive force.

The design of a multi-orifice shock absorber features a double cylinder arrangement with space between the concentric shock tube and cylinder, and a series of orifice holes drilled down the length of the shock tube wall.

During piston movement, the check ring is seated and oil is forced through the orifices in the shock tube wall, into the closed cellular foam accumulator and behind the piston head.

As the piston head moves it closes off orifice holes, thus reducing the available orifice area in proportion to the velocity. After the load is removed the coil spring pushes the piston rod outward. This unseats the check ring and permits the oil to flow from the accumulator and across the piston head, back into the shock tube. This allows quick repositioning for the next impact.

Low Pressure multiple orifice shock absorbers can provide progressive or self-compensating damping, depending on the impact conditions.

PMXT 1525 → PMXT 2150 Series

Standard

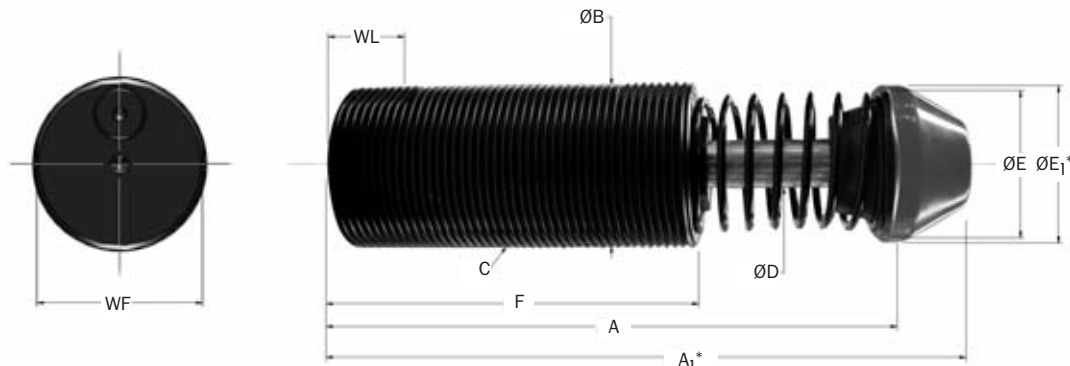

*Note: A₁ and E₁ apply to button models and urethane striker cap accessory.

Catalog No./ Model	(S) Stroke in. (mm)	(E _T) Max. in.-lbs./cycle (Nm/cycle)	(E _T C) Max. in.-lbs./hour (Nm/h)	(F _P) Max. Reaction Force lbs. (N)	Nominal Coil Spring Force		(F _D) Max. Propelling Force lbs. (N)	Weight (mass) lbs. (Kg)
					Extended lbs. (N)	Compressed lbs. (N)		
PMXT 1525	1.00 (25,0)	3,250 (367,0)	1,120,000 (126 000)	6,500 (29 000)	11.0 (48,0)	15.0 (68,0)	1,500 (6 700)	2.2 (1,0)
PMXT 1550	2.00 (50,0)	6,500 (735,0)	1,475,000 (167 000)	6,500 (29 000)	11.0 (29,0)	18.0 (78,0)	1,500 (6 700)	2.4 (1,1)
PMXT 1575	3.00 (75,0)	10,000 (1 130,0)	1,775,000 (201 000)	6,500 (29 000)	7.0 (31,0)	18.0 (78,0)	1,500 (6 700)	2.7 (1,3)
PMXT 2050	2.00 (50,0)	16,500 (1 865,0)	2,400,000 (271 000)	13,750 (60 500)	17.0 (80,0)	35.0 (155,0)	4,000 (17 800)	6.0 (2,7)
PMXT 2100	4.00 (100,0)	33,000 (3 729,0)	3,200,000 (362 000)	13,750 (60 500)	16.0 (69,0)	36.0 (160,0)	4,000 (17 800)	7.3 (3,3)
PMXT 2150	6.00 (150,0)	50,000 (5 650,0)	3,730,000 (421 000)	13,750 (60 500)	20.0 (87,0)	64.0 (285,0)	4,000 (17 800)	9.3 (4,2)

Catalog No./ Model	Damping Constant	A in. (mm)	A ₁ in. (mm)	C in. (mm)	D in. (mm)	E in. (mm)	E ₁ in. (mm)	F in. (mm)	WF in. (mm)	WL in. (mm)
PMXT 1525 IF	-1,-2,-3	5.68	6.37	(IF) 1 3/4-12 UN	.50	1.48	1.75	3.63	1.70	0.75
PMXT 1525 MF	-1,-2,-3	(144,0)	(162,0)	(MF) M45 x 1,5	(12,7)	(38,0)	(44,5)	(92,0)	(43,5)	(19,0)
PMXT 1550 IF	-1,-2,-3	7.68	8.37	(IF) 1 3/4-12 UN	.50	1.48	1.75	4.63	1.70	0.75
PMXT 1550 MF	-1,-2,-3	(195,0)	(213,0)	(MF) M45 x 1,5	(12,7)	(38,0)	(44,5)	(118,0)	(43,5)	(19,0)
PMXT 1575 IF	-1,-2,-3	9.68	10.37	(IF) 1 3/4-12 UN	.50	1.48	1.75	5.63	1.70	0.75
PMXT 1575 MF	-1,-2,-3	(246,0)	(264,0)	(MF) M45 x 1,5	(12,7)	(38,0)	(44,5)	(143,0)	(43,5)	(19,0)
PMXT 2050 IF	-1,-2,-3	8.90	9.55	(IF) 2 1/2-12 UN	.75	1.98	2.25	5.50	2.42	0.75
PMXT 2050 MF	-1,-2,-3	(226,0)	(243,0)	(MF) M64 x 2,0	(19,0)	(50,0)	(57,0)	(140,0)	(61,5)	(19,0)
PMXT 2100 IF	-1,-2,-3	12.90	13.55	(IF) 2 1/2-12 UN	.75	1.98	2.25	7.50	2.42	0.75
PMXT 2100 MF	-1,-2,-3	(328,0)	(345,0)	(MF) M64 x 2,0	(19,0)	(50,0)	(57,0)	(191,0)	(61,5)	(19,0)
PMXT 2150 IF	-1,-2,-3	17.97	18.62	(IF) 2 1/2-12 UN	.75	2.38	2.38	9.50	2.42	0.75
PMXT 2150 MF	-1,-2,-3	(956,0)	(473,0)	(MF) M64 x 2,0	(19,0)	(60,0)	(60,0)	(241,0)	(61,5)	(19,0)

Notes: 1. Dash numbers in page color are non-standard lead time items, contact ITT Enidine.
 2. See page 59 for constant damping curves.
 3. Urethane striker caps are available as accessories for models PM 1525 to PM 2150.

Non-Adjustable Series Hydraulic Shock Absorbers

PMXT Mid-Bore Series

Accessories

PMXT 1525 CM → PMXT 2150 CM Series

Clevis Mount

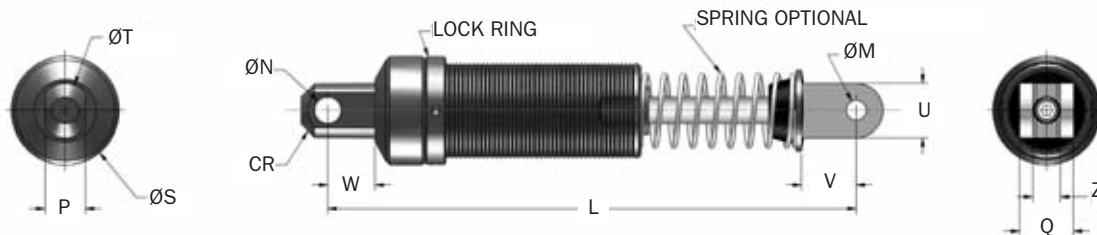

Catalog No./ Model	L in. (mm)	M +.005/-0.000 (+0,13/-0,00) in. (mm)	N +.005/-0.000 (+0,13/-0,00) in. (mm)	P +.000/-0.010 (+0,00/-0,25) in. (mm)	Q +.000/-0.010 (+0,00/-0,25) in. (mm)	S in. (mm)	T in. (mm)	U in. (mm)	V in. (mm)	W in. (mm)	Z +.020/-0.000 (+0,51/-0,00) in. (mm)	CR in. (mm)	Weight (mass) lbs. (Kg)
Δ PMXT 1525 CM (S)	7.84 (199)	.376 (9,60)	.501 (12,70)	.750 (19,00)	1.00 (25,4)	2.00 (51)	1.00 (25)	1.00 (25)	1.01 (26)	.87 (22)	.505 (12,9)	.56 (14,3)	3.0 (1,36)
Δ PMXT 1550 CM (S)	9.84 (250)	.376 (9,60)	.501 (12,70)	.750 (19,00)	1.00 (25,4)	2.00 (51)	1.00 (25)	1.00 (25)	1.01 (26)	.87 (22)	.505 (12,9)	.56 (14,3)	3.2 (1,45)
Δ PMXT 1575 CM (S)	11.84 (300)	.376 (9,60)	.501 (12,70)	.750 (19,00)	1.00 (25,4)	2.00 (51)	1.00 (25)	1.00 (25)	1.01 (26)	.87 (22)	.505 (12,9)	.56 (14,3)	3.6 (1,63)
Δ PMXT 2050 CM (S)	12.06 (306)	.751 (19,07)	.751 (19,07)	1.250 (31,70)	1.50 (38,0)	2.88 (73)	1.50 (38)	1.50 (38)	1.40 (35)	1.06 (26)	.630 (16,0)	.90 (23,0)	8.2 (3,72)
Δ PMXT 2100 CM (S)	16.06 (408)	.751 (19,07)	.751 (19,07)	1.250 (31,70)	1.50 (38,0)	2.88 (73)	1.50 (38)	1.50 (38)	1.40 (35)	1.06 (26)	.630 (16,0)	.90 (23,0)	9.3 (4,22)
Δ PMXT 2150 CM (S)	21.13 (537)	.751 (19,07)	.751 (19,07)	1.250 (31,70)	1.50 (38,0)	2.88 (73)	1.50 (38)	1.50 (38)	1.40 (35)	1.06 (26)	.630 (16,0)	.90 (23,0)	11.2 (5,08)

Notes: 1. Δ = Non-standard lead time items, contact ITT Enidine.

2. (S) indicates model comes with spring.

Flange Foot Mount

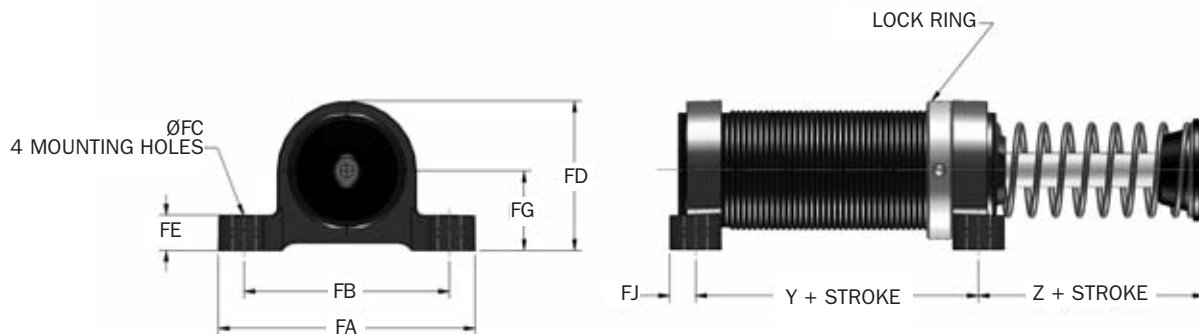

Catalog No./ Model	Part Number	Model (Ref)	Y in. (mm)	Z in. (mm)	FA in. (mm)	FB in. (mm)	FC in. (mm)	FD in. (mm)	FE in. (mm)	FG in. (mm)	FJ in. (mm)	Bolt Size in. (mm)	Kit Weight oz. (g)	Notes
FM 1 3/4 - 12	2FE2740	PMXT 1500 Series	2.38 (60,5)	1.06 (26,9)	3.75 (95,3)	3.00 (76,2)	.34 (8,60)	2.16 (55,0)	.50 (12,7)	1.16 (29,5)	.38 (9,7)	5/16	12.0 oz. (370)	3
FM M45 x 1,5	2FB637	PMXT 1500M Series										M8		3
FM 2 1/2 - 12	2FE3010	PMXXT 2000 Series	3.00 (76,2)	1.56 (39,6)	5.63 (143,0)	4.88 (124,0)	.41 (10,40)	3.38 (85,6)	.63 (16,0)	1.75 (44,5)	.44 (11,2)	3/8	2.3 lbs. (1 050)	1,3
FM M64 x 2	2F3010	PMXT 2000M Series										M10		1,3

Notes: 1. PM 2150 Z dimension is 2.69 in.

2. Shock absorber must be ordered separately from foot mount kit.

3. All foot mount kits include two foot mounts and lock ring.

PMXT 1525 → PMXT 2150 Series

Stop Collar (SC)

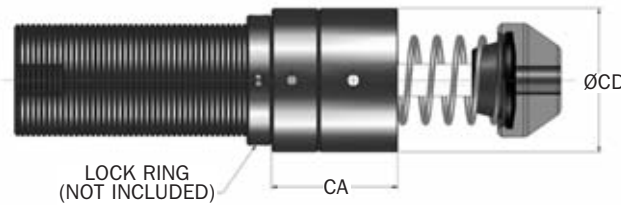

Catalog No./ Model	Part Number	Model (Ref)	CA in. (mm)	CD in. (mm)	Weight (mass) oz. (g)
SC 1 3/4 - 12	8KE2940	PMXT 1500 Series	1.94	2.22	12.0
SC M45 x 1,5	8K8637	PMXT 1500M Series	(49,0)	(56,5)	(340)
SC 2 1/2 - 12 x 2	8KE3010	PMXT 2050 / 2100 Series	2.47	3.00	23.0
SC M64 x 2 x 2	M93010057	PMXT 2050M Series	(89,0)	(76,0)	(936)
SC 2 1/2 - 12 x 6	8KE3012	PMXT 2150 Series	3.66	3.00	35.0
SC M64 x 2 x 4	M93011057	PMXT 2100M Series	(114,0)	(76,0)	(1 191)
SC M64 x 2 x 6	M93012057	PMXT 2150M Series	(143,0)	(76,0)	(1 475)

Note: 1. Part numbers in page color are non-standard lead time items, contact ITT Enidine.

Urethane Striker Cap (USC)

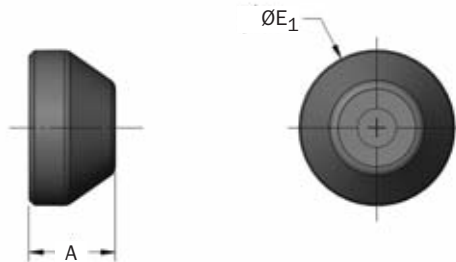

Catalog No./ Model	Part Number	Model (Ref)	A in. (mm)	E ₁ in. (mm)	Weight (mass) oz. (g)
UC 2940	C92940079	PMXT 1500	.97 (24,5)	1.75 (44,5)	0.5 (14)
UC 3010	C93010079	PMXT 2000	.95 (24,0)	2.25 (57,0)	0.8 (23)

Lock Ring (LR)

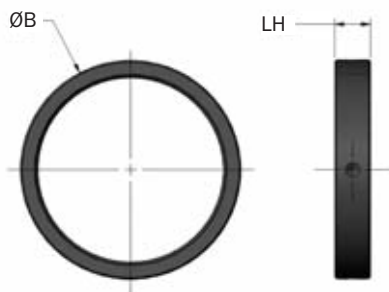

Catalog No./Model	Part Number	Model (Ref)	B in. (mm)	LH in. (mm)	Weight (mass) oz. (g)
LR 1 3/4 - 12	F8E2940049	PMXT 1500 Series	2.00	.38	2.0
LR M45 x 1,5	F88637049	PMXT 1500M Series	(57,2)	(9,5)	(75)
LR 2 1/2 - 12	F8E3010049	PMXT 2000 Series	2.88	.38	3.0
LR M64 x 2	F83010049	PMXT 2000M Series	(72,9)	(12,7)	(85)

Square Flange (SF)

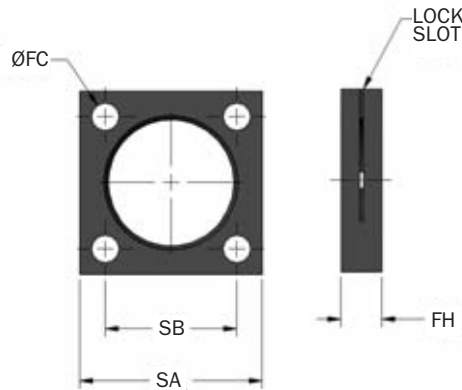

Catalog No./ Model	Part Number	Model (Ref)	FC in. (mm)	FH in. (mm)	SA in. (mm)	SB in. (mm)	Bolt Size in. (mm)	Weight (mass) oz. (g)
SF 1 3/4 - 12	M4E2940056	PMXT 1500 Series	.34	.50	2.25	1.63	3/16	5
SF M45 x 1,5	M48637056	PMXT 1500M Series	(8,6)	(12,7)	(57,2)	(41,3)	(M8)	(140)
SF 2 1/2 - 12	M4E3010056	PMXT 2000 Series	.41	.62	3.50	2.75	3/8	20
SF M64 x 2	M43010056	PMXT 2000M Series	(10,4)	(15,7)	(85,1)	(69,9)	(M10)	(570)

Rectangular Flange (RF)

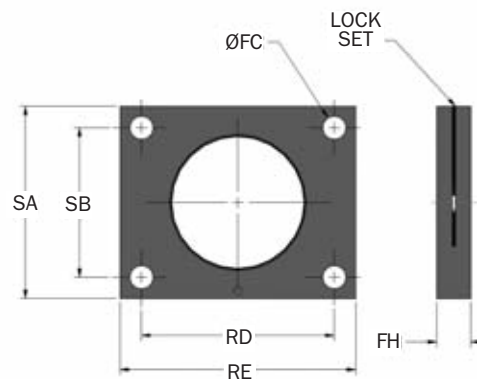

Catalog No./ Model	Part Number	FC Model (Ref)	FH in. (mm)	RD in. (mm)	RE in. (mm)	SA in. (mm)	SB in. (mm)	Size in. (mm)	Bolt (mass) in. (mm)	Wt. oz. (g)
RF 1 3/4 - 12	M5E2940053	PMXT 1500 Series	.34	.50	2.38	3.00	2.25	1.63	3/16	9
RF M45 x 1,5	M58637053	PMXT 1500M Series	(8,6)	(12,7)	(60,5)	(76,2)	(57,2)	(41,4)	(M8)	(260)

PM 120/125 → PMXT 2150 Series

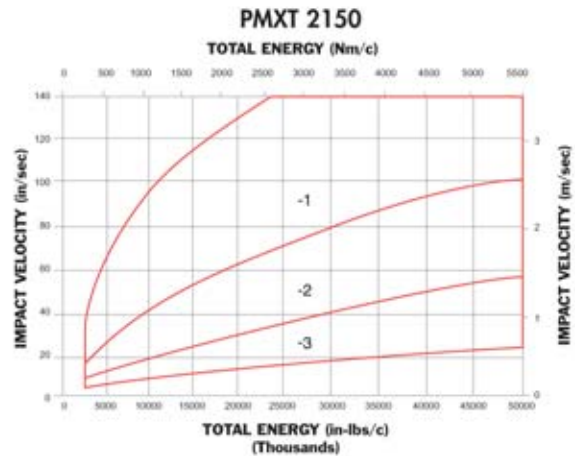
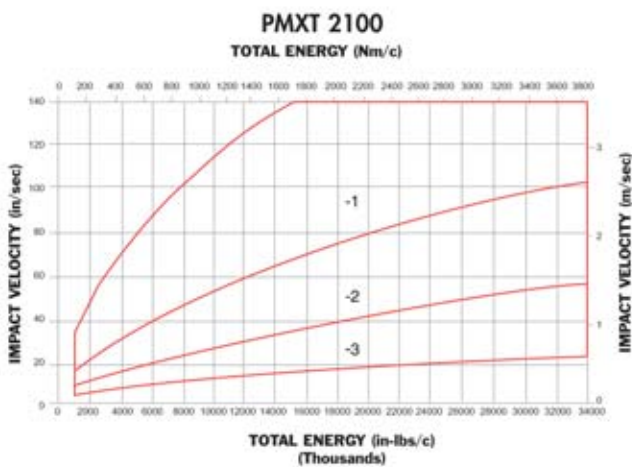
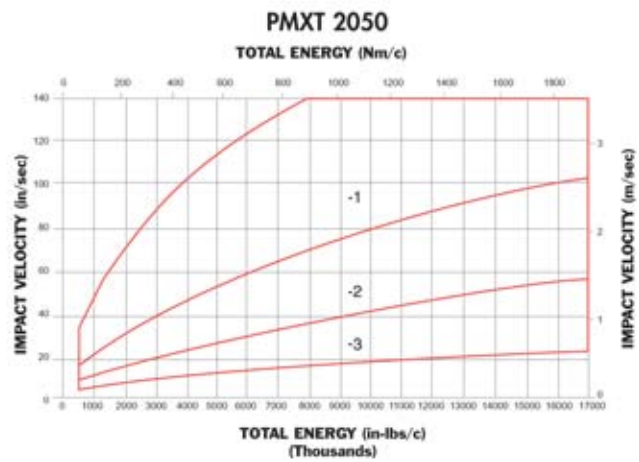
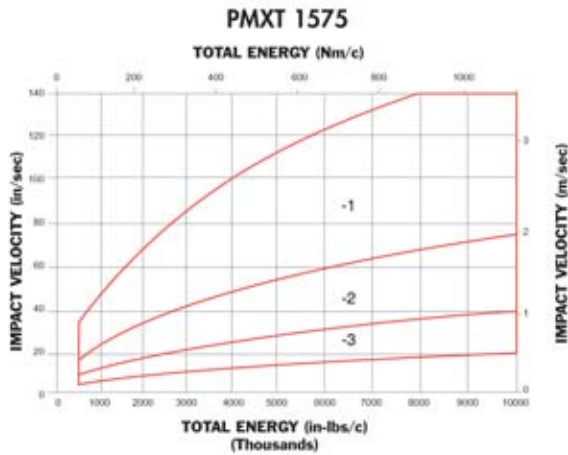
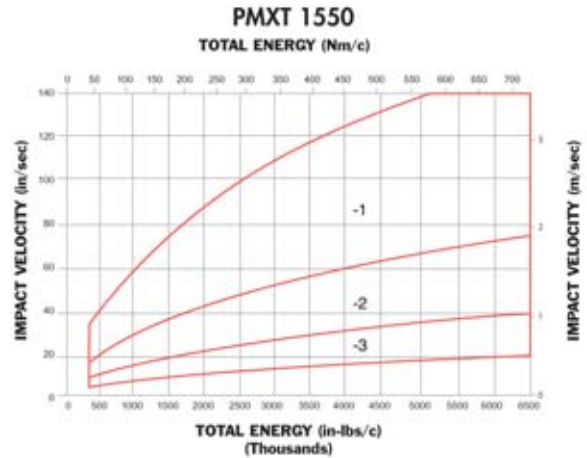
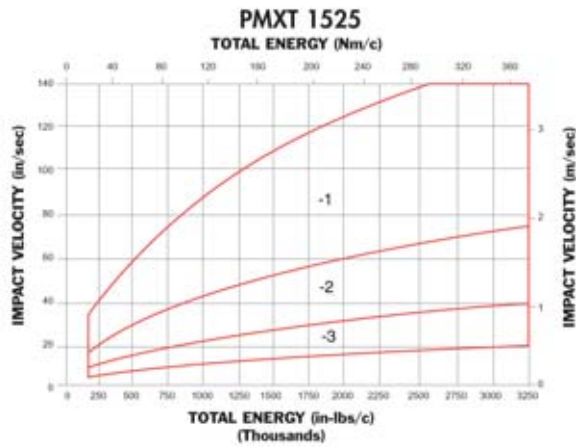

Note: Minimum impact velocity for PM models is 4 in./sec. (0,1 m/sec).



Automated Handling



Conveyor Systems



Robotics