



Enidine Rate Controls are designed to regulate the speed and time required for a mechanism to move from one position to another. Adjustable and non-adjustable models are available to accommodate a wide variety of motion control applications. Both single and double acting hydraulic damper designs allow smooth, controllable machine operation by providing rate control for both linear and rotational (hinged) loads. Each product family offers a variety of stroke lengths from which to choose.

Adjustable, Double Acting (ADA 500M and ADA 700M Series) rate controls regulate speed in both tension and/or compression modes independently. ADA products let the user adjust the rate to suit specific application requirements. Fixed orifice interchangeable cartridges are available for the ADA 500M Series, which provide tamperproof operation once the desired rate has been determined. An optional remote adjustment cable provides adjustment control in otherwise inaccessible locations for the ADA 500M Series.

The **DA Series** are non-adjustable, custom-orificed at factory, double acting rate controls which provide smooth, reliable motion control for high load capacities. Tow bar (TB) snubbers are specially designed DA's which dampen the abrupt starts and stops of power and free conveying systems.

Features and Benefits

- Extensive product line offers flexibility in both size and load capacities to fulfill a wide range of application requirements.
- Custom stroke lengths and damping characteristics can be designed to suit your application requirements.
- ISO quality standards result in reliable, long-life operation.
- Incorporating optional fluids can expand the standard operational temperature range from (-10°C to -80°C) to (-30°C to -100°C).
- A select variety of surface finishes maintains original quality appearance and provides the longest corrosion resistance protection.
- Special materials and finishes available to meet specific customer requirements.

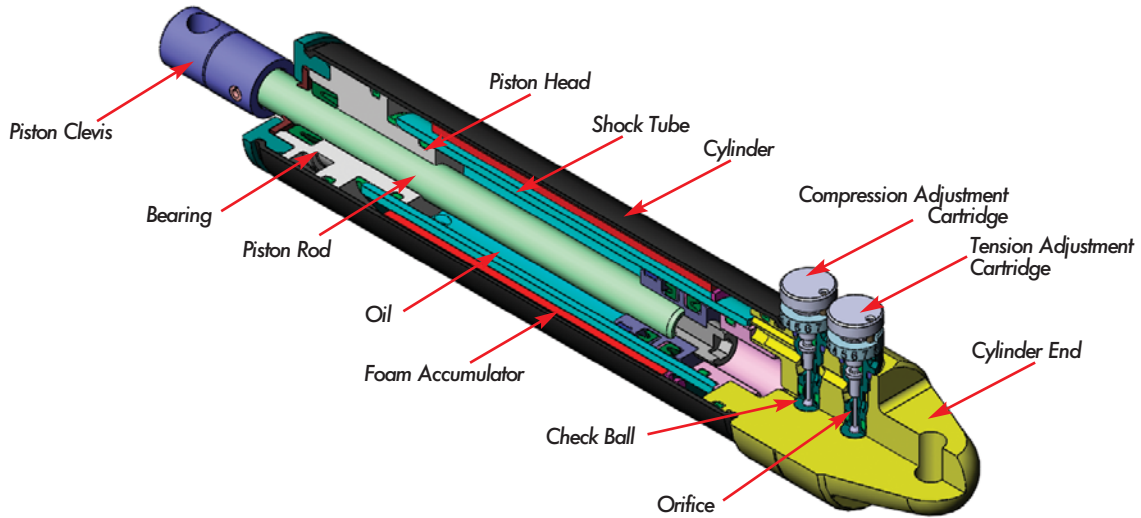

Enidine Double Acting Adjustable (ADA) rate controls control the velocity of both linear and rotational loads throughout their entire motion. Adjustment cartridges on the ADA 500M Series allow flexibility in controlling the speed for an applied force in both the tension and compression directions. Maximum damping is achieved by turning the adjustment knob to the number eight (8) setting, while turning the knob to the zero (0) setting provides minimal resistance. Interchangeable, threaded, fixed-orifice cartridges can provide consistent, tamper-resistant damping to meet particular application requirements.

The ADA 500M Series utilizes two independent adjustment cartridges for motion control in each direction, housed in the cylinder end. The ADA 700M Series has independently controlled tension and compression capabilities located at each end of the unit.

Resistance is controlled by using a wrench key at either end of the rate control and adjusting the movement by following the stiffer (+) or softer (-) indications. When the rate control is compressed, the oil is orificed through the compression adjustment cartridge and flows freely through the tension adjustment cartridge. The tension cartridge check ball unseats and allows free flow of the oil to the rod end of the shock tube. A foam accumulator is utilized to accept the volume of oil displaced by the piston rod. When the rate control is extended, oil is moved through an internal flow path in the shock tube and is orificed through the tension adjustment cartridge. The compression cartridge check ball unseats and allows free flow of the oil into the blind end of the shock tube.

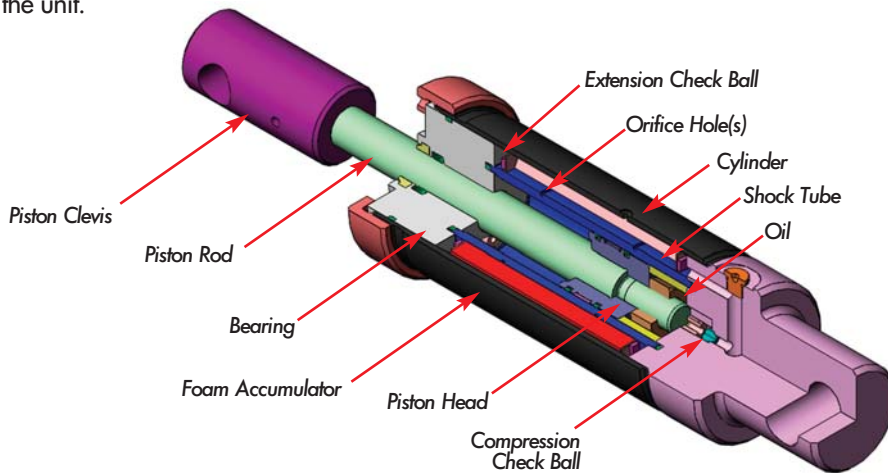

DA Series rate controls are ideally suited for high-energy, heavy load applications requiring rate control in tension, compression or both directions. These non-adjustable, custom-orificed units are designed to specific input conditions, and allow for single and multiple orifice configurations.

Upon compression of the rate control, the compression check ball seats. As the piston head moves, oil is forced through the orifice hole(s) located in the shock tube, producing the required damping force. After the oil has

passed through the orifice hole(s), a portion of the oil passes through the extension check valve and fills the rod end of the shock tube. The remainder of the oil volume displaced by the piston rod compresses the foam accumulator.

Upon extension of the rate control, the extension check ball seats. As the piston head moves, oil is forced through the orifice hole(s) located in the shock tube producing the required damping force. The compression check ball is unseated by the flow of oil which fills the blind end of the shock tube.

Enidine Rate Controls are used to regulate the speed or time required for a mechanism to move from one position to another. They use proven technology to enhance performance in a variety of product applications. Rate controls are typically used to control pneumatic cylinders, linear slides, lids, and other moving mechanisms.

The advantages of using rate controls include:

- 1. Longer Machine Life** – The use of rate controls significantly reduces shock and vibration to machinery caused by uncontrolled machine operation. This further reduces machinery damage, downtime and maintenance costs, while increasing machine life.
- 2. Improved Production Quality** – Harmful effects of uncontrolled motion, such as noise, vibration and damaging impacts, are moderated or eliminated so that production quality is improved.
- 3. Safer Machinery Operation** – Rate controls protect machinery and equipment operators by offering predictable, reliable and controlled machine operation.
- 4. Competitive Advantage** – Machines and end products become more valuable because of increased productivity, longer life, lower maintenance and safer operation.

Enidine offers a wide range of rate controls that provide motion control in tension, compression, or both directions. Adjustable and non-adjustable tamperproof models are available to fit your particular application requirements.

The resisting force provided by Enidine rate controls is typically constant over the entire stroke when the piston rod is moved at a constant velocity, since the rate controls are single orifice products. DA Series models can be custom orificed to provide increasing resisting force over the stroke through the use of multiple orifices in the shock tube. This can be beneficial when controlling the velocity of a lid as it closes, since the torque from the weight of the lid changes as it closes.

Rate Control Adjustment Techniques

A properly adjusted rate control safely controls machinery operation, and reduces noise levels from uncontrolled motion. To correctly adjust the rate control after it has been properly sized for the application, set the adjustment knob (per the useable adjustment setting graphs for the applicable model). Cycle the mechanism and observe the motion of the system.

If the motion of the mechanism is too fast, move the adjustment dial to the next largest number until the desired velocity is achieved.

If the motion of the mechanism is too slow, move the adjustment dial to the next smallest number until the desired velocity is achieved.

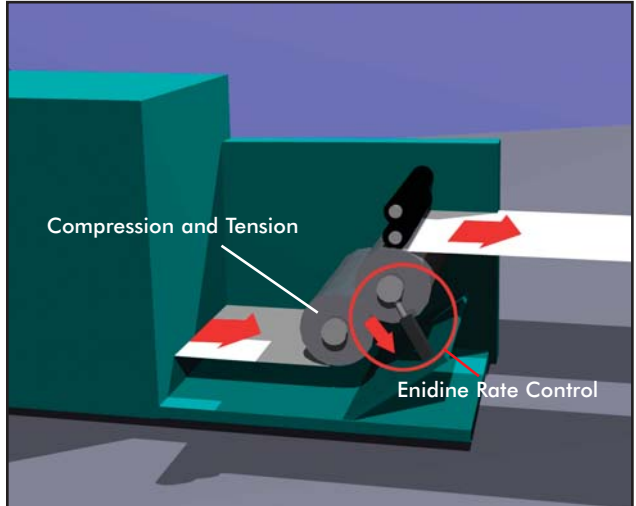
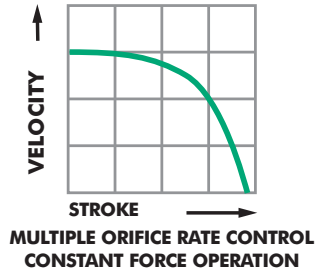
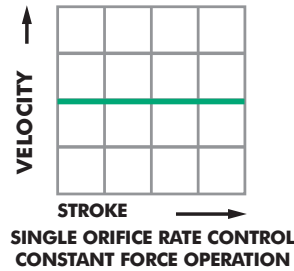

Typical Application: Print Rollers and Paper Tensioners

Useable Adjustment Setting Range

Green lines are model's maximum allowable propelling force.

ADA 500

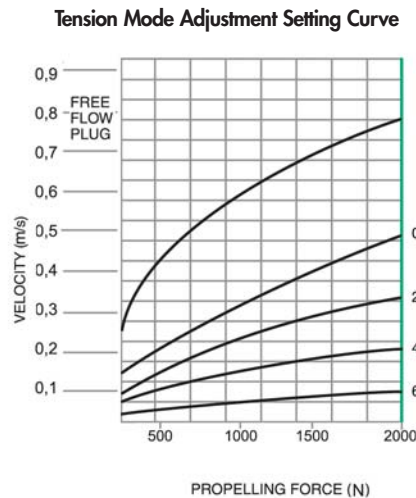
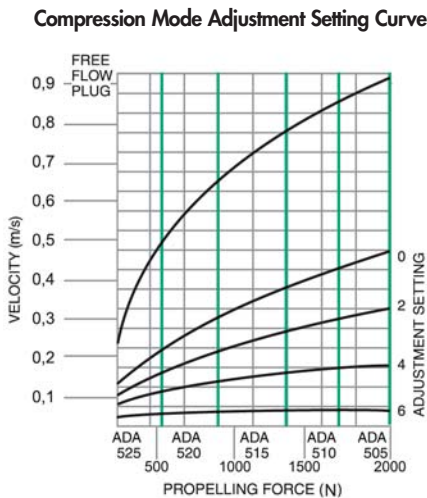

Position 0 provides minimum damping force. Position 8 provides maximum damping force. 180° adjustment with setscrew locking.

- Determine the damping direction (tension [T], compression [C] or both [T and C]), stroke (mm) required, propelling force (N), desired velocity (m/s) and cycles per hour.
 - Calculate total energy per hour (Nm/hr).
 - Compare the damping direction (T, C, or T and C), stroke (mm) required, propelling force (N) and total energy per hour (Nm/hr) to the values listed in the Rate Controls Engineering Data charts.
- NOTE:** Propelling force and velocity should be measured at the location of the rate control.
- Determine if adjustable or non-adjustable model is desired.
 - Select the appropriate rate control model.
 - For adjustable rate control models, refer to the Useable Adjustment Settings section for the selected model to determine the proper adjustment setting.
 - For non-adjustable rate control models, refer to the Damping Constant Selection Instructions for the selected model to determine the proper damping constant.

Example:

- Damping Direction (T,C or T and C): T and C
 Stroke (S): 102 mm
 Propelling Force (F_D): 890 N (T and C)
 Velocity (V): 0,2 m/s
 Cycles/Hour (C): 20
- Total Energy/Hour:

1 808 Nm/hr compression
1 808 Nm/hr tension
<hr style="width: 100%;"/>
3 616 Nm/hr Total
- Compare damping direction (T and C), stroke, propelling force and total energy per hour, to the values listed in the rate controls engineering data charts.
- An adjustable model is desired.
- Selection: ADA 510M (T and C), The proper adjustment is two (2) in tension and compression per the ADA 500M Series Useable Adjustment Setting Range Curves.

After properly sizing the ADA, the adjustment setting can be determined.

- To determine the approximate adjustment setting when the selected model, propelling force, and velocity are known: compare velocity to the propelling force in the compression and/or tension mode adjustment setting curves. The intersection point of the velocity and the propelling force is the approximate adjustment setting to be used. Adjustment higher or lower than this setting will result in slower or faster damper operation, respectively.
- To determine the velocity when the selected model, adjustment setting, and propelling force are known: compare the propelling force to the adjustment setting in the compression and/or tension mode adjustment setting curves. The intersection point of the propelling force and the adjustment setting is the approximate velocity for the selected model. Higher velocities are obtained at lower adjustment settings and lower velocities are obtained at higher adjustment settings.

EXAMPLE: Double Acting Application

Stroke required: 51 mm
 Control direction: Tension and Compression
 Propelling force: 1 557 N (tension),
 1 780 N (compression)

- Selection: ADA 505
- Velocity: 0,28 m/s (tension),
 0,15 m/s (compression)
 Intersection point: Adjustment setting 2 (tension),
 4 (compression)
 - Adjustment setting: 2 (tension), 4 (compression)
 Velocity: 0,28 m/s (tension),
 0,15 m/s (compression)

NOTE: When a free flow plug is used, the intersection point of the propelling force and free flow plug curve determines the velocity.

NOTE: Propelling force and velocity should be measured at the location of the rate control.

Useable Adjustment Setting Range
Green lines are models maximum allowable propelling force.

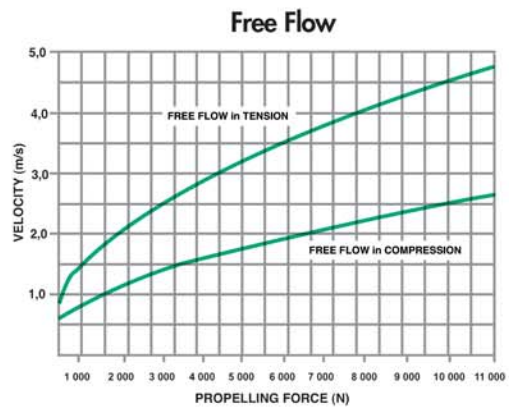
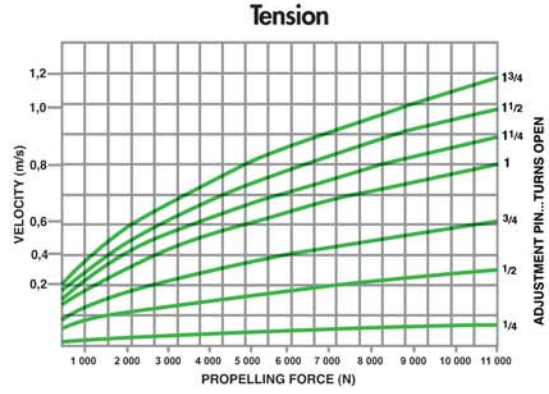
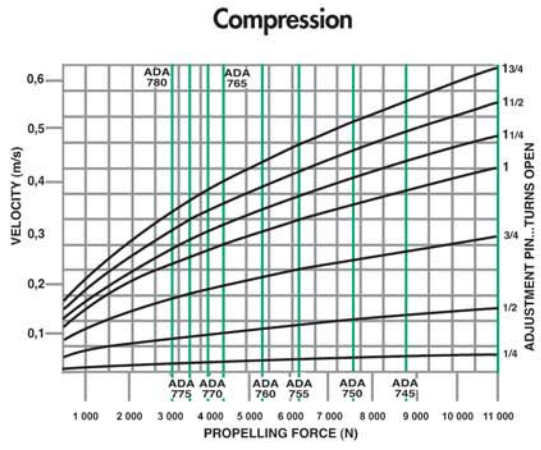

Turn adjustment pin 1 3/4 turns open to provide minimum damping force. Turn adjustment pin fully closed to provide maximum damping force.

1. To determine the approximate adjustment setting, when the selected model, propelling force, and velocity are known, compare velocity to the propelling force in the compression and/or tension mode adjustment setting curves. The intersection point of the velocity and the propelling force is the approximate adjustment setting to be used. Adjustment lower or higher than this setting will result in slower or faster damper operation respectively.
2. To determine the velocity, when the selected model, adjustment setting, and propelling force are known, compare the propelling force to the adjustment setting in the compression and/or tension mode adjustment setting curves. The intersection point of the propelling force and the adjustment setting is the approximate velocity for the selected model. Higher velocities are obtained at higher adjustment settings and lower velocities are obtained at lower adjustment settings.
3. A 1,5mm Hex Wrench (provided) is required to adjust the unit.

NOTE: When a free flow plug is used, the intersection point of the propelling force and free flow plug curve determines the velocity.

EXAMPLE: Adjustable Double Acting Rate Control Application

Stroke required: 152 mm
Control direction: Tension and Compression
Propelling force: 4 4448 N (tension), 7 228 N (compression)

- Selection: ADA 715
1. Velocity: 0,635 m/s (tension), 0,1 m/s (compression)

Intersection point: Adjustment setting 1 1/2 (tension), 1/2 (compression)
 2. Adjustment setting: 1 1/2 (tension), 1/2 (compression)

Velocity: 0,635 m/s (tension), 0,1 m/s (compression)

NOTE: Propelling force and velocity should be measured at the location of the rate control.

ADA 500 Series

Example: **10**
Select quantity

ADA 505M
Select Catalog No. from Engineering Data chart or Accessory chart

T4
Select Tension Mode
• T Adjustable
• T (0-6) Non-Adjustable*
• P Free Flow

C
Select Compression Mode
• C Adjustable
• C (0-6) Non-Adjustable*
• P Free Flow

*Note: Select adjustment setting (from Adjustment Setting Curve[s]) to be duplicated in non-adjustable cartridge.

ADA 700 Series

Example: **10**
Select quantity

ADA 770M
Select Catalog No. from Engineering Data chart or Accessory chart

C
Tension Mode:
Adjustable
• P Free Flow

T
Compression Mode:
Adjustable
• P Free Flow

B
G - Threaded Only
A - Clevis
B - Swivel Bearing
C - Fork
D - Knee Joint

C
G - Threaded Only
A - Clevis
B - Swivel Bearing
C - Fork
D - Knee Joint

DA Series

All DA Models are custom orificed. Application data must be supplied when ordering. Please provide all application data for unique part number assignment.

Example: **10**
Select quantity

DA 75M X 50
Select Catalog No. from Engineering Data chart

APPLICATION DATA

Specify for damping in tension, compression or both, as applicable:

- Vertical, Horizontal or Rotary† Motion
- Propelling Force
- Other (temperature, environmental conditions, etc.)
- Velocity
- Cycles per Hour
- Weight

NOTE: Propelling force and velocity should be measured at the location of the rate control.

Application Worksheet

FAX NO.: _____
DATE: _____
ATTN: _____
COMPANY: _____

APPLICATION DESCRIPTION

The Enidine Application Worksheet makes shock absorber sizing and selection easier.

Fax, phone, or mail worksheet data to Enidine headquarters or your nearest Enidine subsidiary/affiliate or distributor. (See catalog back cover for Enidine locations, or visit www.enidine.eu for a list of Enidine distributors.)

Upon Enidine's receipt of this worksheet, you will receive a detailed analysis of your application and product recommendations. (For custom design projects, Enidine representatives will consult with you for specification requirements.)

Motion Direction (Check One):

Horizontal Vertical Up Incline Angle _____
 Down Height _____

Rotary Horizontal Rotary Vertical Up
 Down

Weight (Min./Max.): _____ (Kg)

Cycle Rate: _____ (cycles/hour)

Additional Propelling Force (If known): _____ (N)

Air Cyl: Bore _____ (mm) Max. Pressure _____ (bar) Rod Dia. _____ (mm)

Hydraulic Cyl: Bore _____ (mm) Max. Pressure _____ (bar)

Rod Dia. _____ (mm)

Motor _____ (kW) Torque _____ (Nm)

Ambient Temp.: _____ (°C)

Environmental Considerations: _____

GENERAL INFORMATION

CONTACT: _____
DEPT/TITLE: _____
COMPANY: _____
ADDRESS: _____
TEL: _____ FAX: _____
EMAIL: _____
PRODUCTS MANUFACTURED: _____

SHOCK ABSORBER APPLICATION

(All Data Taken at Shock Absorber)

Number Shock Absorbers to Stop Load

Impact Velocity (min./max.): _____ (m/s)

Shock Absorber Stroke Requirements: _____ (mm)

(a) Load Requirements: _____ (m/s²)

RATE CONTROL APPLICATION

(All Data Taken at Rate Control)

Number of Rate Controls to Control the Load: _____

Control Direction: Tension (T) Compression (C)

Required Stroke: _____ (mm) Est. Stroke Time _____ (s)

Estimated Velocity at the Rate Control _____ (m/s)

ADA 505M → ADA 525M Series

Rate Controls

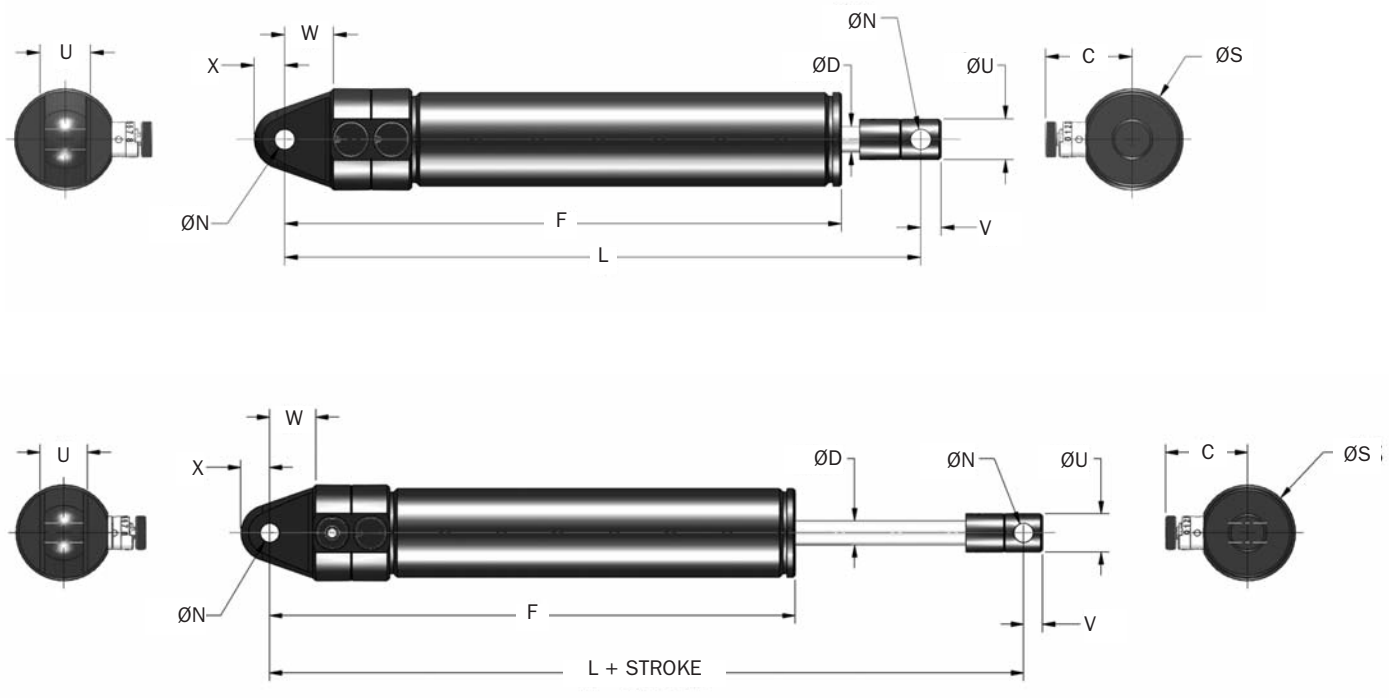

Catalog No./ Model	Damping Direction	Bore Size mm	(S) Stroke mm	F _D Max. Propelling Force		E _T C Max. Nm/hr	Model Mass Kg
				Extension N	Compression N		
ADA 505M	T, C or T and C	16,0	50,0	2 000	2 000	73 450	0,3
ADA 510M	T, C or T and C	16,0	100,0	2 000	1 670	96 050	0,372
ADA 515M	T, C or T and C	16,0	150,0	2 000	1 335	118 650	0,445
ADA 520M	T, C or T and C	16,0	200,0	2 000	900	141 250	0,520
ADA 525M	T, C or T and C	16,0	250,0	2 000	550	163 850	0,590

Catalog No./ Model	C mm	D mm	F mm	L mm	N mm +0,13/-0,00	S mm	U mm +0,00/-0,381	V mm	W mm	X mm
ADA 505M	27,0	8,0	173,0	200	6,0	31,8	12,7	6,3	14,2	9,5
ADA 510M	27,0	8,0	224,0	250	6,0	31,8	12,7	6,3	14,2	9,5
ADA 515M	27,0	8,0	275,0	300	6,0	31,8	12,7	6,3	14,2	9,5
ADA 520M	27,0	8,0	325,0	350	6,0	31,8	12,7	6,3	14,2	9,5
ADA 525M	27,0	8,0	376,0	400	6,0	31,8	12,7	6,3	14,2	9,5

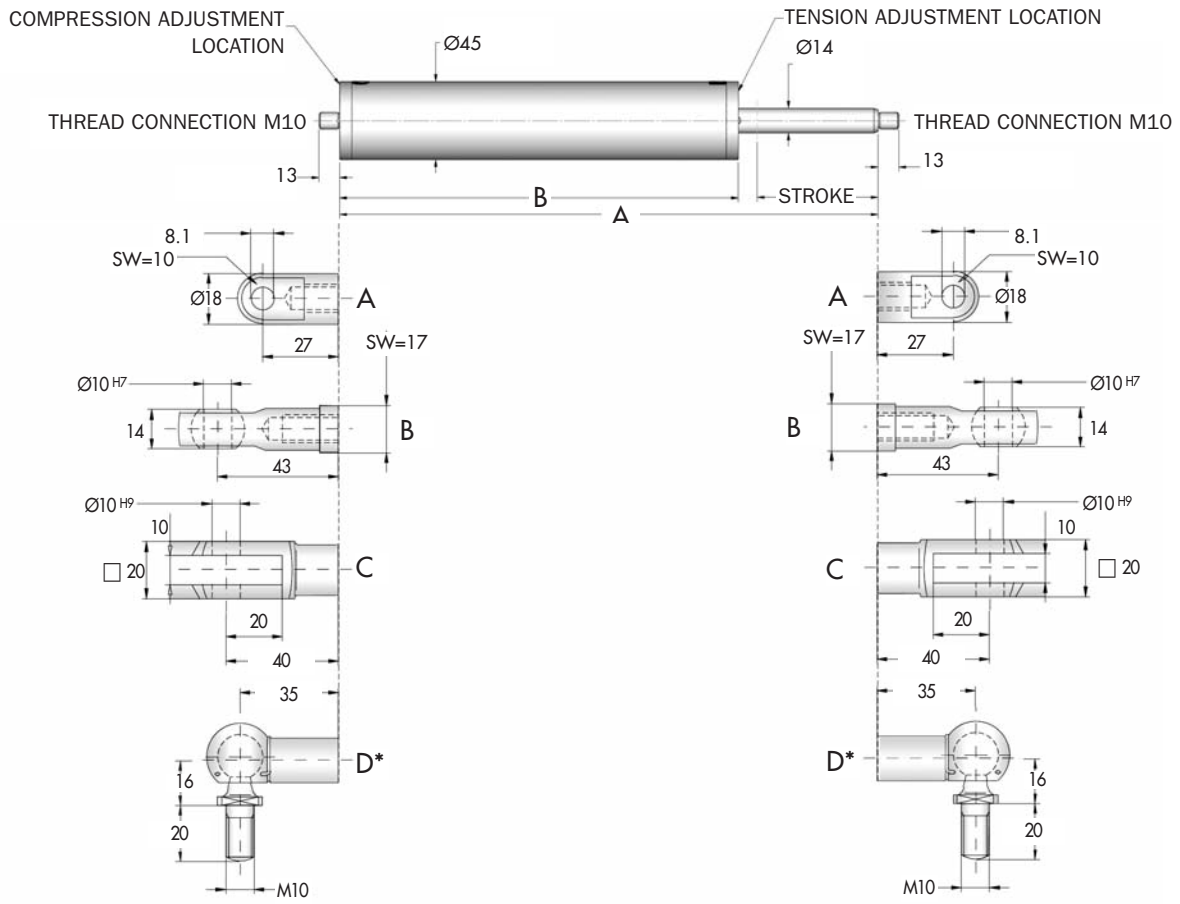

Catalog No./ Model	Damping Direction	Bore Size mm	(S) Stroke mm	FD Max. Propelling Force		E _T C Max Nm/hr	Model Mass Kg	A mm	B mm
				Tension N	Compression N				
△ ADA 705M	T, C or T and C	25	50,0	11 000	11 000	129 000	1,6	237	180
△ ADA 710M	T, C or T and C	25	100,0	11 000	11 000	168 000	2,0	339	231
△ ADA 715M	T, C or T and C	25	150,0	11 000	11 000	206 000	2,3	441	282
△ ADA 720M	T, C or T and C	25	200,0	11 000	11 000	247 000	2,6	541	332
△ ADA 725M	T, C or T and C	25	250,0	11 000	11 000	286 000	2,9	643	383
△ ADA 730M	T, C or T and C	25	300,0	11 000	11 000	326 000	3,2	745	434
△ ADA 735M	T, C or T and C	25	350,0	11 000	11 000	366 000	3,6	847	485

*Notes: 1. The maximum load capacity for mounting option D is 1 600 N.
 2. △ = Non-standard lead time items, contact Enidine.

ADA 740M → ADA 780M Series

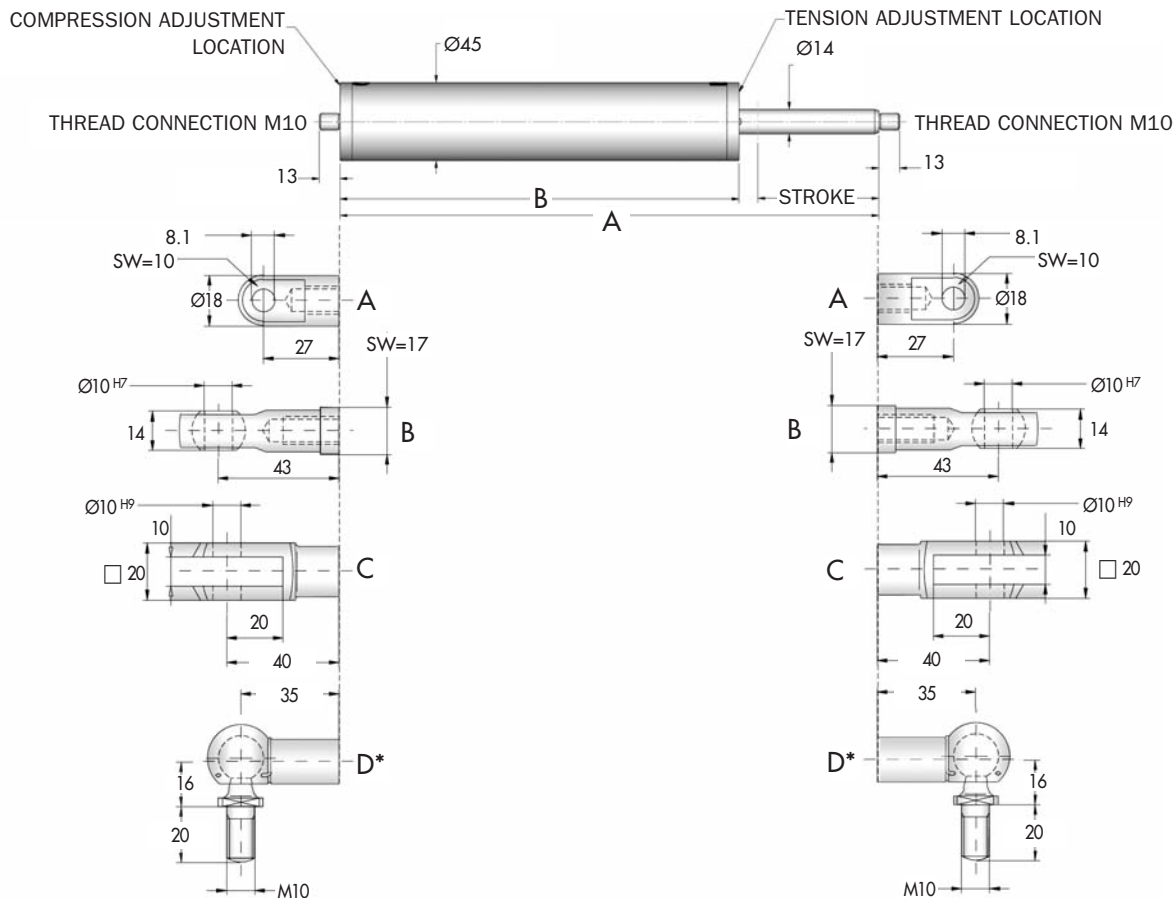

Catalog No./ Model	Damping Direction	Bore Size mm	(S) Stroke mm	FD Max. Propelling Force		E _T C Max Nm/hr	Model Mass Kg	A mm	B mm
				Tension N	Compression N				
△ADA 740M	T, C or T and C	25	400	11 000	11 000	405 000	3,9	947	535
△ADA 745M	T, C or T and C	25	450	11 000	8 800	444 000	4,2	1 049	586
△ADA 750M	T, C or T and C	25	500	11 000	7 500	484 000	4,5	1 151	637
△ADA 755M	T, C or T and C	25	550	11 000	6 200	524 000	4,8	1 253	688
△ADA 760M	T, C or T and C	25	600	11 000	5 300	563 000	5,2	1 355	739
△ADA 765M	T, C or T and C	25	650	11 000	4 500	603 000	5,5	1 457	790
△ADA 770M	T, C or T and C	25	700	11 000	4 000	642 000	5,8	1 557	840
△ADA 775M	T, C or T and C	25	750	11 000	3 500	681 000	6,1	1 659	891
△ADA 780M	T, C or T and C	25	800	11 000	3 100	721 000	6,5	1 761	942

*Notes: 1. The maximum load capacity for mounting option D is 1 600 N.
 2. △= Non-standard lead time items, contact Enidine.

Remote Adjustment Cable for ADA 500 Series

Enidine will custom fit a remote adjustment cable for applications where the ADA unit will be mounted in non-accessible locations. Contact Enidine for more information.

Note: If rotary application, please complete application worksheet on page 104 and forward to Enidine.

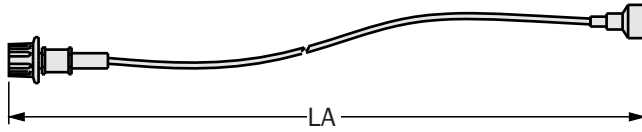

Standard remote adjustment cable length is 1220 mm. Optional lengths available upon request.
Note: Remote adjustment cable can be used in a single position only.

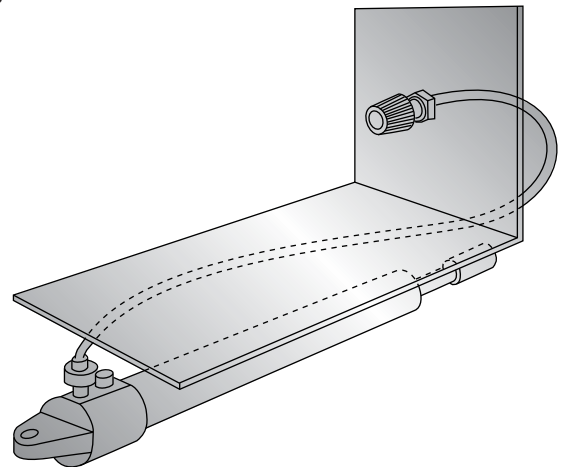

Adjustable Cartridge

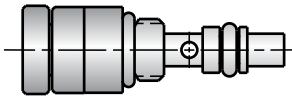

Free Flow Plug

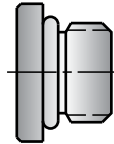

Non-Adjustable Cartridge

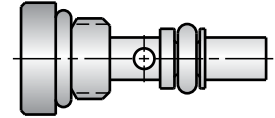

Catalog No.	Part Number	Accessory Description	LA mm	Weight g
RAC48	1K495748	Remote Adjustment Cable	1220	191
RAC4957	AJ4957325	Adjustable Cartridge	Notes "x" specify desired setting "0-6". May be used in place of adjustable cartridge. For installing adjustable and non-adjustable cartridges. Provides least amount of damping force for ADA Models.	
NAC "x"	NJ"x"4957327	Non-Adjustable Cartridge (0-6)		
CW4957	2L4957302	Cartridge Wrench		
FFP4957	PA4957326	Free Flow Plug		

DA 50M x 50 → DA 75M x 100 Series

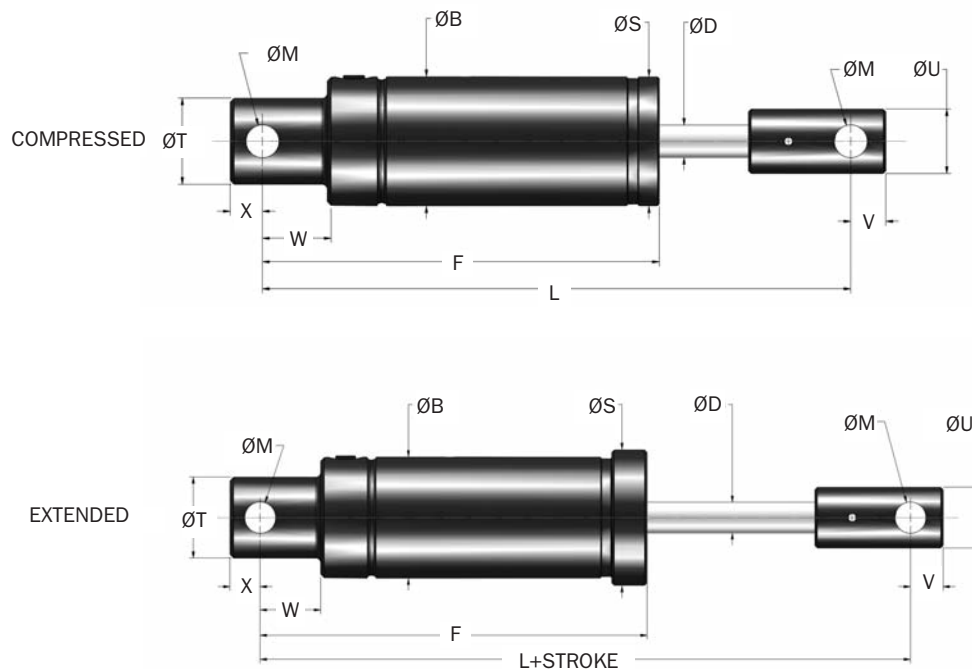

Catalog No./ Model	Damping Direction	Bore Size mm	(S) Stroke mm	F _D Max. Propelling N	E _T Max. Nm/c	E _T C Max. Nm/hr	Model Mass Kg
DA 50M x 50	T, C or T and C	28,7	50,0	11 121	565	158 179	1,59
DA 50M x 100	T, C or T and C	28,7	100,0	11 121	1 120	192 074	2,27
DA 50M x 150	T, C or T and C	28,7	152,4	11 121	1 695	225 970	2,95
DA 50M x 200	T, C or T and C	28,7	203,2	11 121	2 260	259 865	3,63
DA 75M x 50	T, C or T and C	38,0	50,0	22 250	1 120	305 000	11,4
DA 75M x 100	T, C or T and C	38,0	100,0	22 250	2 240	350 000	13,2

Catalog No./ Model	B mm	D mm	F mm	L mm	M ±0,38 mm	S mm	T ±0,38 mm	U ±0,25 mm	V mm	W mm	X mm
DA 50M x 50	50,8	14,2	193	253	14,7	57,2	38,1	28,6	14,2	28,7	14,2
DA 50M x 100	50,8	14,2	243	304	14,7	57,2	38,1	28,6	14,2	28,7	14,2
DA 50M x 150	50,8	14,2	294	355	14,7	57,2	38,1	28,6	14,2	28,7	14,2
DA 50M x 200	50,8	14,2	345	406	14,7	57,2	38,1	28,6	14,2	28,7	14,2
DA 75M x 50	76,0	19,0	245	348	19,4	86,0	51,0	38,0	21,0	38,0	19,0
DA 75M x 100	76,0	19,0	295	398	19,4	86,0	51,0	38,0	21,0	38,0	19,0

Notes: 1. DA Models will function at 10% of their maximum rated energy per cycle. If less than 10%, a smaller model should be specified.

2. Provide a positive stop 3 mm before end of stroke in tension and compression to prevent internal bottoming.

3. For optimal performance in vertical applications using compression, mount the rate control with the piston rod down.

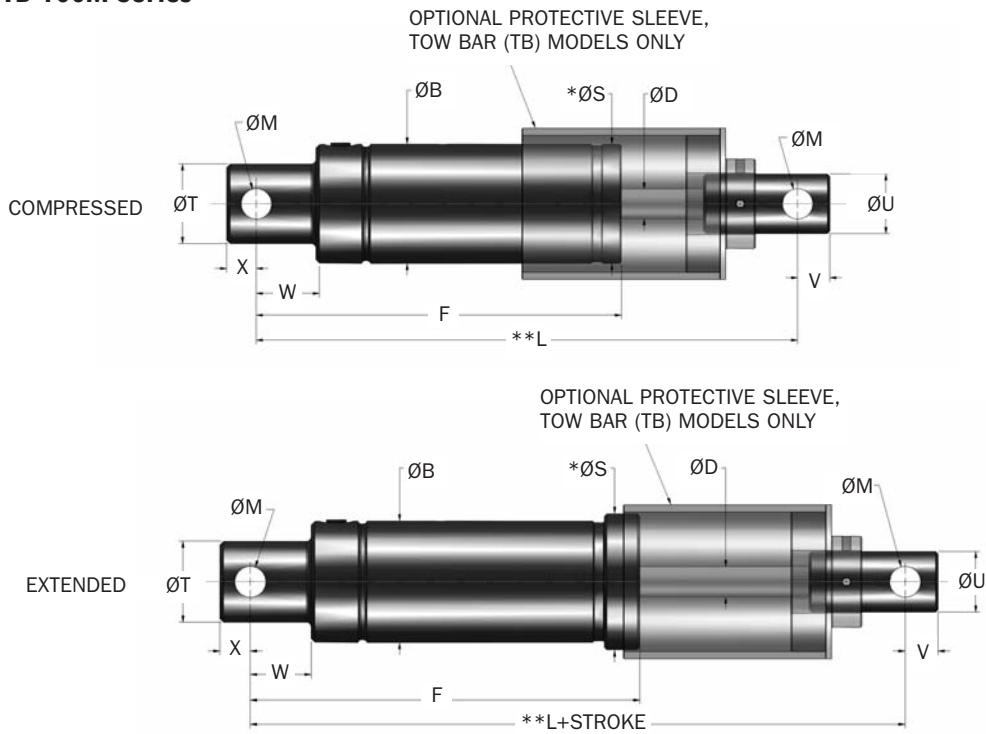

Catalog No./ Model	Damping Direction	Bore Size mm	(S) Stroke mm	F _D Max. Propelling N	E _T Max. Nm/c	E _T C Max. Nm/hr	Model Mass Kg
DA 75M x 150	T, C or T and C	38,0	150,0	22 250	3 360	406 000	15,0
DA 75M x 200	T, C or T and C	38,0	200,0	22 250	4 480	463 000	16,8
DA 75M x 250	T, C or T and C	38,0	250,0	22 250	5 600	508 000	18,6
TB 100M x 100	T and C	57,2	100,0	44 482	4 480	497 133	14,5
TB 100M x 150	T and C	57,2	150,0	44 482	6 779	497 133	14,5

Catalog No./ Model	B mm	D mm	F mm	L mm	M ±0,38 mm	S mm	T ±0,38 mm	U ±0,25 mm	V mm	W mm	X mm
DA 75M x 150	76,0	19,0	345	448	19,4	86,0	51,0	38,0	21,0	38,0	19,0
DA 75M x 200	76,0	19,0	395	498	19,4	86,0	51,0	38,0	21,0	38,0	19,0
DA 75M x 250	76,0	19,0	445	548	19,4	86,0	51,0	38,0	21,0	38,0	19,0
TB 100M x 100	70,0	25,4	480	616	19,1	82,6	63,5	38,0	19,1	38,0	19,0
TB 100M x 150	70,0	25,4	480	565	19,1	82,6	63,5	38,0	19,1	38,0	19,0

- Notes: 1. DA Models will function at 10% of their maximum rated energy per cycle. If less than 10%, a smaller model should be specified.
 2. Provide a positive stop 3 mm before end of stroke in tension and compression to prevent internal bottoming.
 3. For optimal performance in vertical applications using compression, mount the rate control with the piston rod down.
 4. * ØS indicates outside diameter of optional protective sleeve for TB 100M x 100 models.
 5. ** Dimension L is controlled by a 50 mm stroke limiter.