

Cam Roller Technology

Roller Bearings & Linear Guideways



Hevi-Rail
Heavy Duty Bearing Systems

redi-rail

HEVI-RAIL

V-GUIDE

LOW PROFILE REDI-RAIL

REDI-RAIL

COMMERCIAL RAIL

HARDENED CROWN ROLLER

PBC
LINEAR

A PACIFIC BEARING CO.

1-800-962-8979

www.pbclinear.com



Product Comparison

Line drawings shown at 2:1 scale.

REDI-RAIL Metric Series

Radial capacities from 1000 to 5950 N

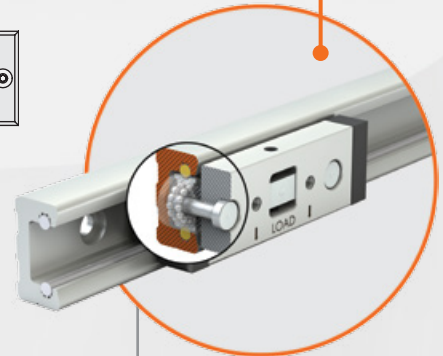
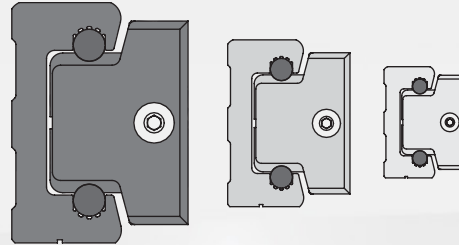

Patented side adjustable preload makes fine-tuning easy for the optimal fit

REDI-RAIL Inch Series

Radial capacities from 340 to 850 lbs.

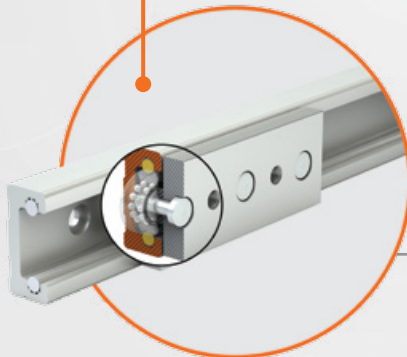
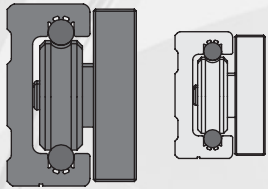

Industrial strength rail and slider are sealed against contamination

HEVI-RAIL

Bearing and rail system static radial capacities from 5.23 to 59.2 kN

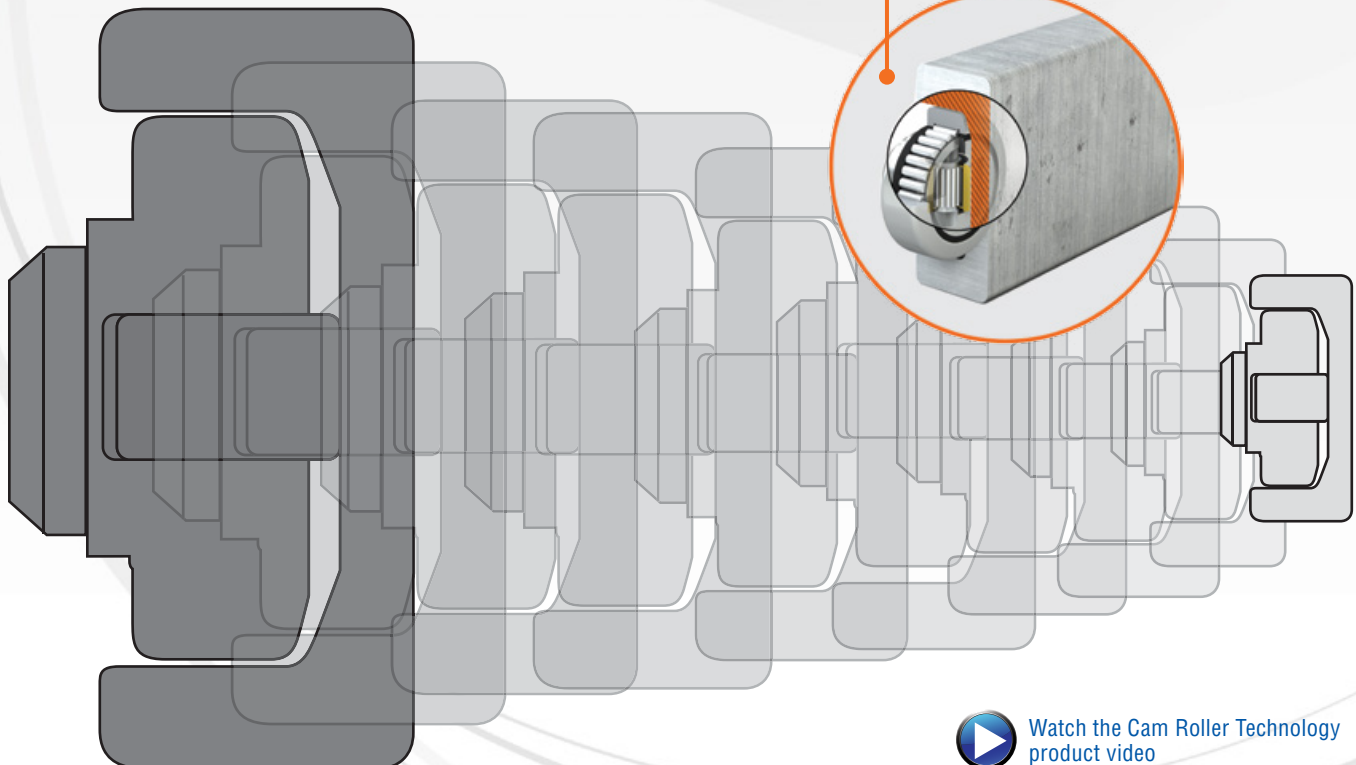

Heavy duty bearing system handles extremely high loads and is cost effective



Watch the Cam Roller Technology product video

Product Comparison



Line drawings shown at 2:1 scale.

LOW PROFILE REDI-RAIL

Radial capacity to 1220 N

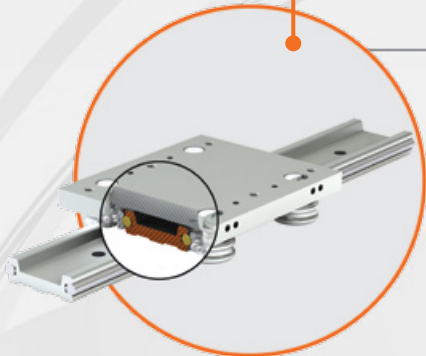

Low 19 mm profile is lightweight and thrives in tight spaces

Roll formed rails and machined aluminum slider body with preload adjustability



COMMERCIAL RAIL

Radial capacities from 210 to 1330 N

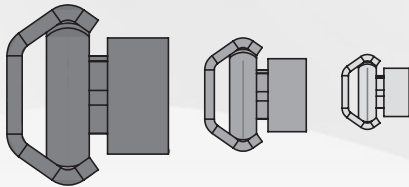

Low cost, strong, long-lasting solution

HARDENED CROWN ROLLER

Loads to 300 lbs.

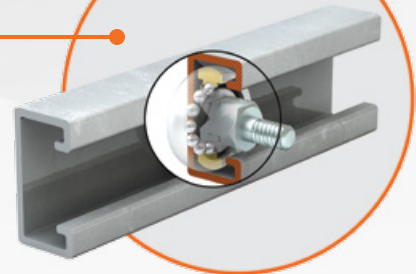
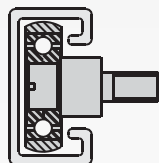

V-GUIDE

Radial capacities from 1260 to 9991 N

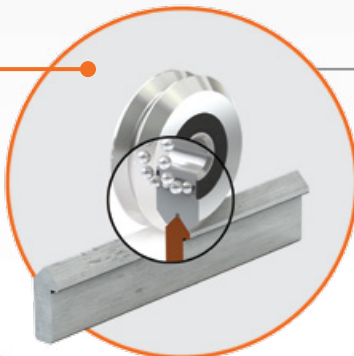
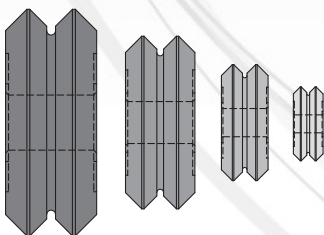

Industry standard v-wheels and rails are a versatile linear motion solution









[Link to whitepaper "Lubrication for Roller Bearings and Raceways"](#)

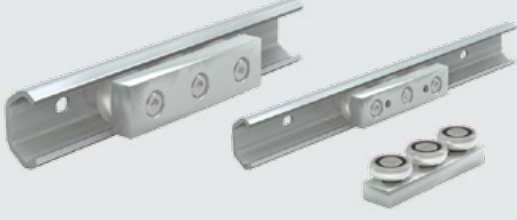

Product Selection Guide

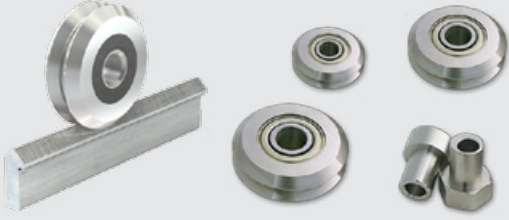
I Inch Series **M** ISO Metric Series

|  CRT CAM ROLLER TECHNOLOGY | | USAGE CRITERIA | | | | | FOUND ON PAGE |
|---|--|------------------------|------------------------|------------------------|------------------------|------------------------|---------------|
| | | PRECISION | MOMENT LOAD | STRUCTURAL ELEMENT | COST | HARSH ENVIRONMENTS | |
| REDI-RAIL & LOW PROFILE REDI-RAIL  | Precision straight rails and hardened gothic arch rollers are ideal for high speed and moderate load linear motion. Rollers are equipped with double-row sealed bearings. Rails are integrated with hardened steel races to ensure strength within a lightweight design. | Best Better Good | Best Better Good | Best Better Good | Best Better Good | Best Better Good | 6 |
| COMMERCIAL RAIL  | Roll formed rails made of zinc plated steel or stainless steel provide a low cost and corrosion resistant solution. Machined aluminum slider body with steel or stainless steel wheels comes with standard adjustable preload. | Best Better Good | Best Better Good | Best Better Good | Best Better Good | Best Better Good | 16 |
| HARDENED CROWN ROLLER  | Pre-assembled rollers are self-aligning for easy installation. Roller bearings combined with rails in steel or powder coated finish are an inexpensive choice for long lasting linear motion. | Best Better Good | Best Better Good | Best Better Good | Best Better Good | Best Better Good | 20 |
| V-GUIDE  | V-Guide components offer an excellent solution for linear applications ranging from very clean to the harshest environments. Industry standard V-Guide wheels and rails are a versatile linear motion solution. | Best Better Good | Best Better Good | Best Better Good | Best Better Good | Best Better Good | 22 |
| HEVI-RAIL  | Hevi-Rail is a heavy-duty linear bearing system that is cost effective for medium to low precision applications. The system is easy to mount, align and use! High radial and axial load capacities ensure a long and productive life under continuous use. | Best Better Good | Best Better Good | Best Better Good | Best Better Good | Best Better Good | 28 |



Inch Series



ISO Metric Series

Contents



REDI-RAIL METRIC SERIES



Technical Information

| | |
|----------------------------------|----|
| Load | 48 |
| Life | 54 |
| Installation & Maintenance . . . | 61 |



REDI-RAIL INCH SERIES



Technical Information

| | |
|----------------------------------|----|
| Load | 48 |
| Life | 54 |
| Installation & Maintenance . . . | 61 |



LOW PROFILE REDI-RAIL



Technical Information

| | |
|----------------------------------|----|
| Load | 48 |
| Life | 54 |
| Installation & Maintenance . . . | 61 |



COMMERCIAL RAIL



Technical Information

| | |
|----------------------------------|----|
| Load | 48 |
| Life | 54 |
| Installation & Maintenance . . . | 61 |



HARDENED CROWN ROLLER

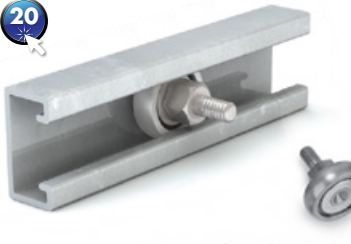

Technical Information

| | |
|----------------------------------|----|
| Load | 20 |
| Life | 54 |
| Installation & Maintenance . . . | 61 |



V-GUIDE



Technical Information

| | |
|----------------------------------|----|
| Load | 51 |
| Life | 54 |
| Installation & Maintenance . . . | 61 |



HEVI-RAIL



Technical Information

| | |
|----------------------------------|----|
| Load | 52 |
| Life | 54 |
| Installation & Maintenance . . . | 61 |

If you are utilizing our digital catalog, you can click these icons throughout the publication to get more information.

Note: Hyperlinks go to English language website.

COMMON BUTTONS & LINKS



[Watch Product Videos](#)



[Email an Application Engineer](#)



[Download CAD](#)



[Link to specific product information](#)



Applications

RACK SYSTEMS & MOBILE COMMAND CENTERS: Hevi-Rail combined roller systems handle extremely high loads in industrial strength applications. Systems can be optimized to provide telescopic sliding solutions.

ERGONOMIC & MOBILE SEAT ADJUSTMENT: Commercial Rail roller bearings, Redi-Rail, and Hardened Crown Roller each offer reliable mechanical roller systems for seat adjustment in clean and dirty environments.

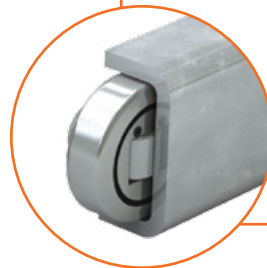

SLIDING DOORS: V-Guide wheels and rails are ideal for sliding door mechanisms. They provide smooth and quiet travel in a wide range of environments.

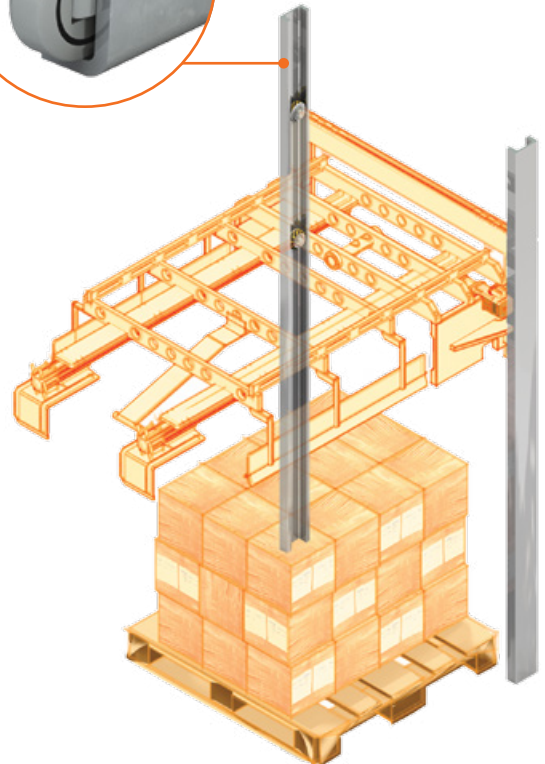
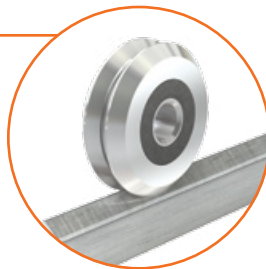
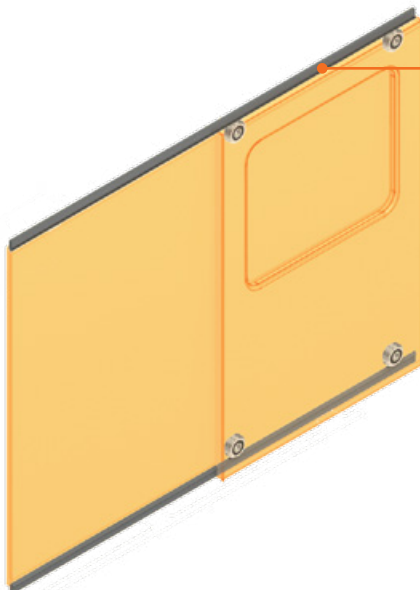

DEPALLETIZERS & HEAVY DUTY LIFT SYSTEMS: Cam Roller products from PBC Linear, such as Hevi-Rail, provide the industrial strength and cantilever load capabilities required in heavy duty lift systems.



Applications

MOBILE EQUIPMENT: PBC Linear's Hevi-Rail and Commercial Rail provide top quality motion control and thrive in harsh environments: extreme temperatures, heavy vibration, high loads and contaminants.

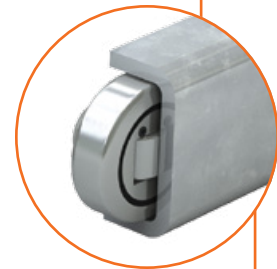
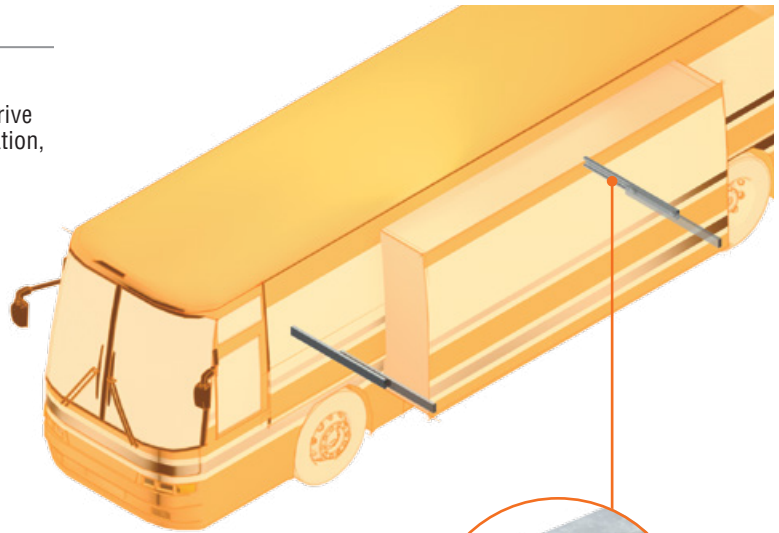
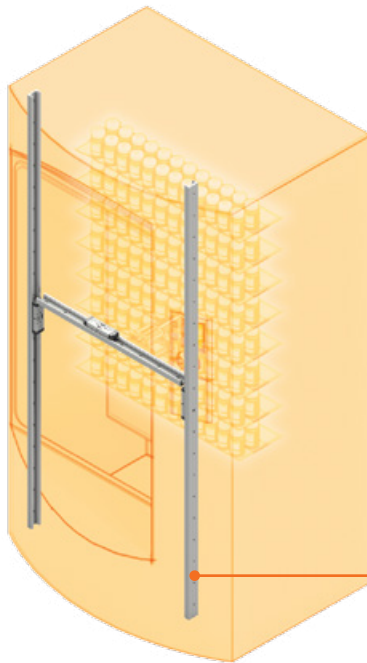

KIOSK & AUTOMATED RETAIL: A motion control solution, such as Redi-Rail, has many benefits including reduced part count, decreased installation costs, and improved performance.

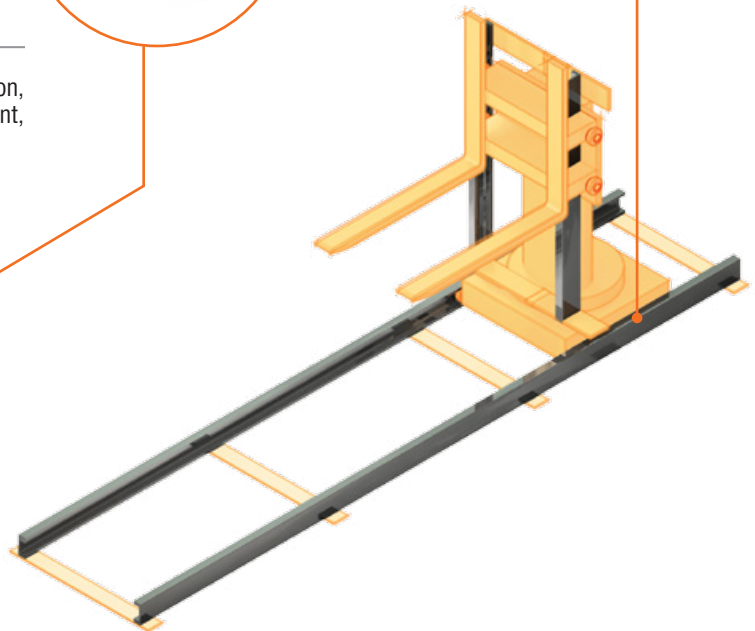
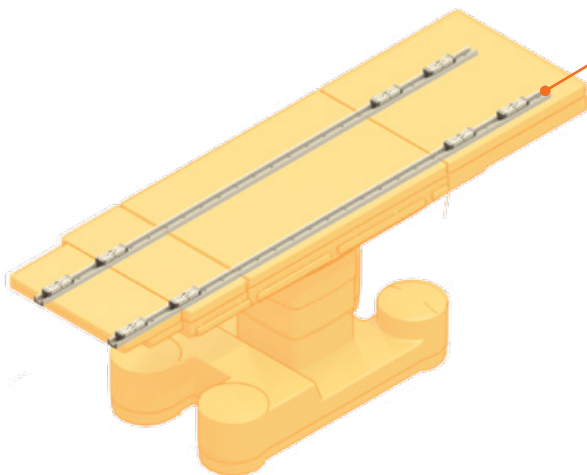

MEDICAL AND LABORATORY EQUIPMENT: Redi-Rail provides smooth and consistent rolling performance for medical applications such as tables, carts, and chairs.

MATERIAL HANDLING AND HEAVY DUTY INDUSTRIAL SYSTEMS: Hevi-Rail bearings provide smooth linear guidance in the toughest applications. Handling loads up to 6.6 tons per bearing, Hevi-Rail is an economical solution in the harshest industrial environments.



Redi-Rail® Linear Guides

METRIC SERIES

| SERIES | # OF ROLLERS | Fd | Fy | Fz | Mx | My | Mz | MAX SPEED | |
|--------|--------------|-----------------------|-------------|------------|------|------|-------|-----------|-----|
| | | DYNAMIC CAPACITY N | RADIAL N | AXIAL N | N-M | N-M | N-M | M/MIN | M/S |
| RR30 | 3 | 1440 | 1000 | 330 | 1.8 | 5.5 | 12.5 | 300 | 5.0 |
| RR45 | 3 | 4404 | 2660 | 827 | 6.6 | 19.9 | 47.9 | 420 | 7.0 |
| RR65 | 3 | 10200 | 5950 | 1678 | 19.0 | 58.2 | 154.7 | 480 | 8.0 |



PRODUCT OVERVIEW

- Patented side adjustment feature makes setting preload easy
- Integral seals to wipe raceway
- Bearings sealed against contamination
- Gothic arch rollers
- Operating temperature range -20°C to 80°C (-4°F to 176°F)
- Oil-filled plastic or UHMW spring loaded wipers
- Custom carriages can be designed, engineered, and manufactured to meet your specific requirements.

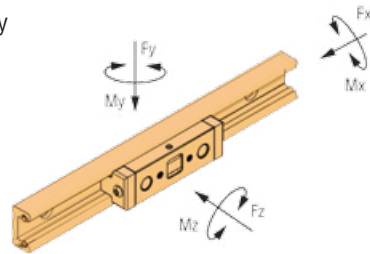

Fd = Dynamic capacity (LC)
 Fz = Axial capacity
 Fy = Radial capacity
 Mx, My, Mz = Moment capacities

Conversions

newton (N) x 0.2248 = lbs.
 (lbf) meter x 0.03937 = inch
 newton - meter (N-m) x 8.851 = in.-lbs.

1:1 SCALE

Dimensions shown in mm.

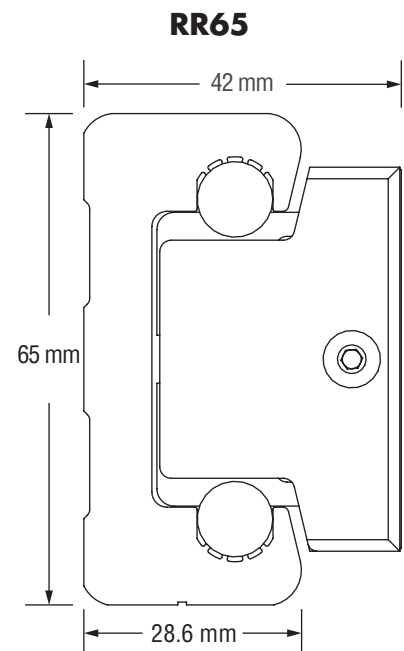
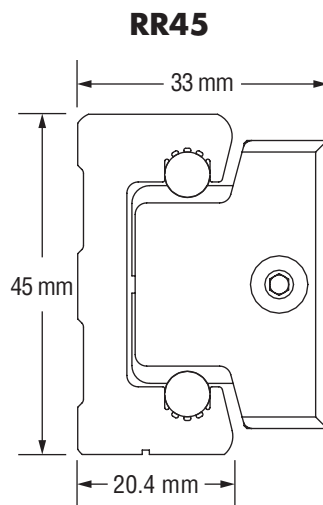
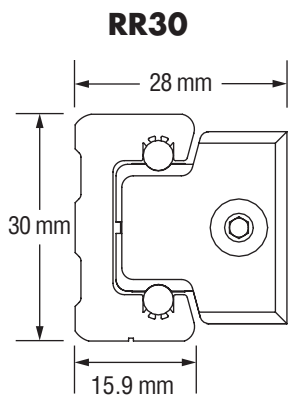

[Link to video "How to Adjust Redi-Rail Carriages"](#)

REDI-RAIL
COMMERCIAL RAIL
HARDENED CROWN ROLLER
V-GUIDE
HEVI-RAIL



Linear Guides **Redi-Rail®**

INCH SERIES

| SERIES | # OF ROLLERS | Fd DYNAMIC CAPACITY | | Fy RADIAL | Fz AXIAL | Mx | My | Mz | MAX SPEED | |
|--------|--------------|---------------------|-----|-----------|----------|--------|--------|--------|-----------|-----|
| | | LBS | LBS | LBS | LBS | IN/LBS | IN/LBS | IN/LBS | FPM | IPM |
| RR14 | 3 | 421 | 340 | 79 | 21 | 54 | 201 | 500 | 6000 | |
| RR18 | 3 | 1032 | 850 | 168 | 67 | 153 | 677 | 800 | 9600 | |

LOW PROFILE

| SERIES | # OF ROLLERS | Fd DYNAMIC CAPACITY | | Fy RADIAL | | Fz AXIAL | | Mx | | My | | Mz | | MAX SPEED | |
|--------|--------------|---------------------|-----|-----------|-----|----------|-----|-----|--------|-----|--------|-----|--------|-----------|------|
| | | N | LBS | N | LBS | N | LBS | N-M | IN/LBS | N-M | IN/LBS | N-M | IN/LBS | FPM | IPM |
| RRL34 | 4 | 1488 | 329 | 1220 | 270 | 510 | 110 | 14 | 120 | 31 | 270 | 13 | 110 | 500 | 6000 |



REDI-RAIL

COMMERCIAL RAIL

HARDENED CROWN ROLLER

V-GUIDE

HEVI-RAIL

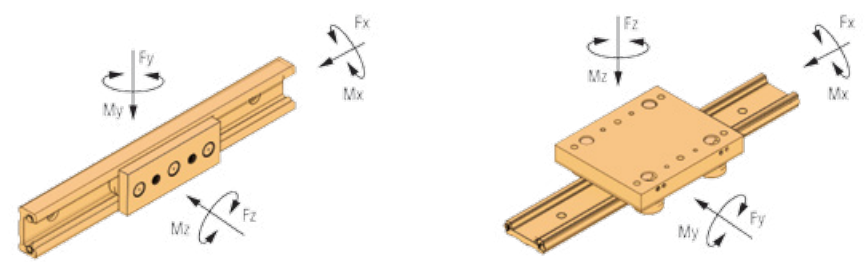

Fd = Dynamic capacity (LC)
 Fz = Axial capacity
 Fy = Radial capacity
 Mx, My, Mz = Moment capacities

Conversions
 newton (N) x 0.2248 = lbs.
 (lbf) meter x 0.0397 = inch
 newton - meter (N-m) x 8.851 = in.-lbs.

1:1 SCALE

Dimensions shown in inches for RR14 & RR18; mm for RRL34.

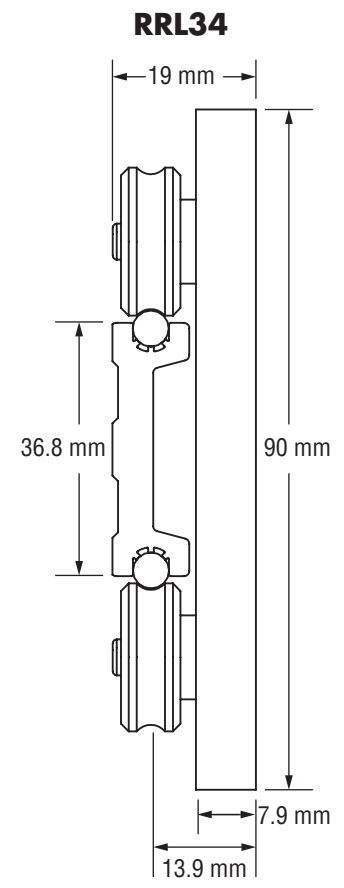
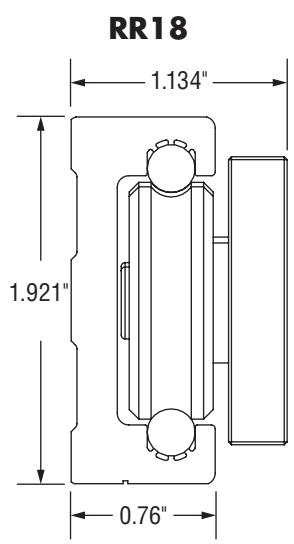
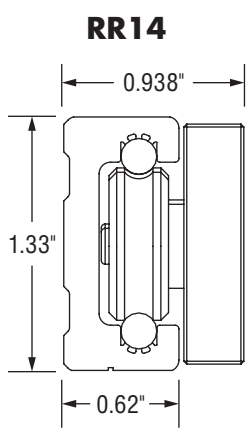

[Link to video "Adjusting Pre-Load on Low Profile Redi-Rail Carriages"](#)



Redi-Rail® Linear Guides

ISO Metric Series

SLIDE DIMENSIONS

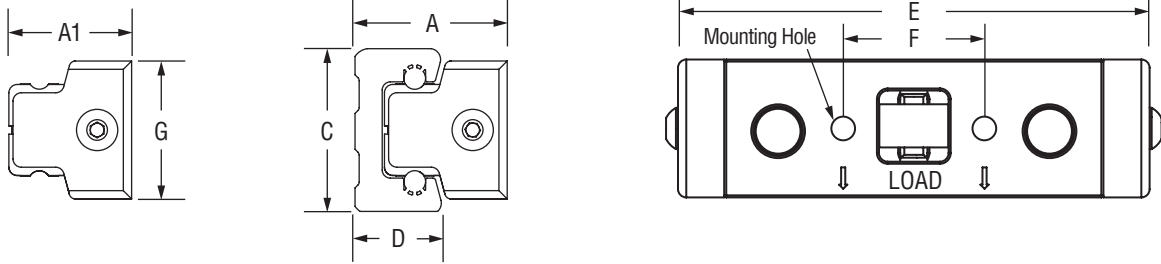

- **SEALED ROLLER**
Ideal around contaminants
- **DOUBLE ROW BEARING**
High speed & acceleration

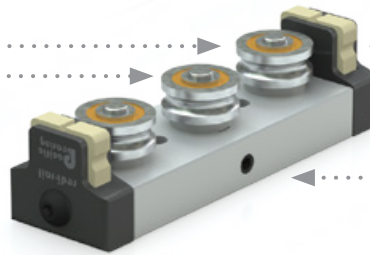

- **WIPER**
Molded plastic casing
spring-load for even pressure
- **PRE-LOAD ADJUSTMENT**
Patented side adjustable preload

DIMENSIONAL INFORMATION mm

| PART NO. | A1 | A | G | C | D | E | F | MOUNTING HOLES | WEIGHT KG |
|----------|------|----|------|----|------|------|----|----------------|-----------|
| RRS30 | 22.6 | 28 | 25.4 | 30 | 15.9 | 86.9 | 26 | M5 x 0.8 | 0.09 |
| RRS45 | 25.8 | 33 | 38.1 | 45 | 20.4 | 117 | 36 | M8 x 1.25 | 0.23 |
| RRS65 | 32.3 | 42 | 50.8 | 65 | 28.6 | 162 | 52 | M8 x 1.25 | 0.54 |

LOAD RATINGS

| PART NO. | Fd | Fy | Fz | Mx | My | Mz |
|----------|-------|------|------|------|------|-------|
| | N | N | N | N-M | N-M | N-M |
| RRS30 | 1440 | 1000 | 330 | 1.8 | 5.5 | 12.5 |
| RRS45 | 4404 | 2660 | 827 | 6.6 | 19.9 | 47.9 |
| RRS65 | 10200 | 5950 | 1678 | 19.0 | 58.2 | 154.7 |

[Download CAD](#)

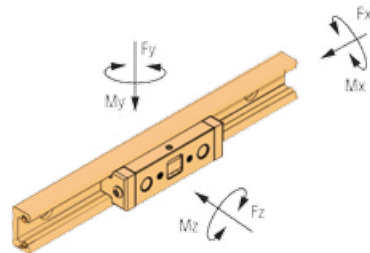

Fd = Dynamic capacity (LC)
Fz = Axial capacity
Fy = Radial capacity
Mx, My, Mz = Moment capacities

Conversions

newton (N) x 0.2248 = lbs.
(lbf) meter x 0.0397 = inch
newton - meter (N-m) x 8.851 = in.-lbs.

SLIDE ORDERING INFORMATION

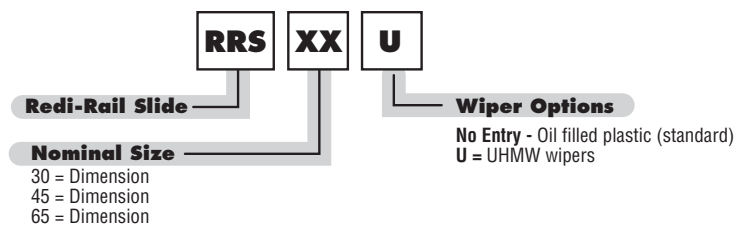

Ordering example: RRS65U

REDI-RAIL
COMMERCIAL RAIL
HARDENED CROWN ROLLER
V-GUIDE
HEVI-RAIL

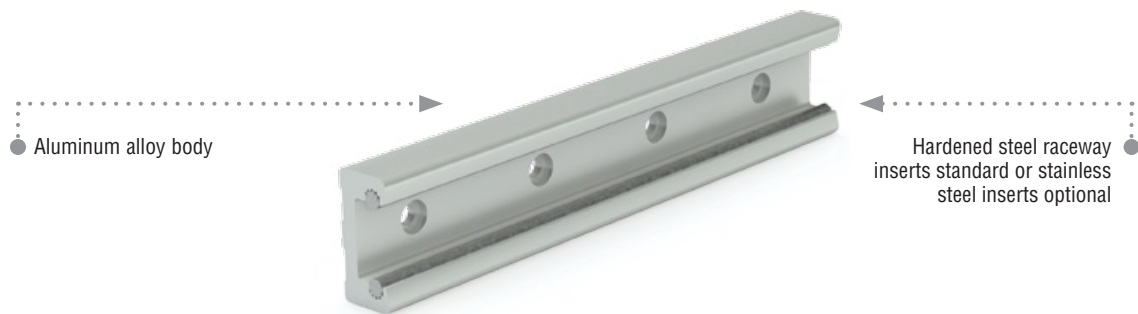
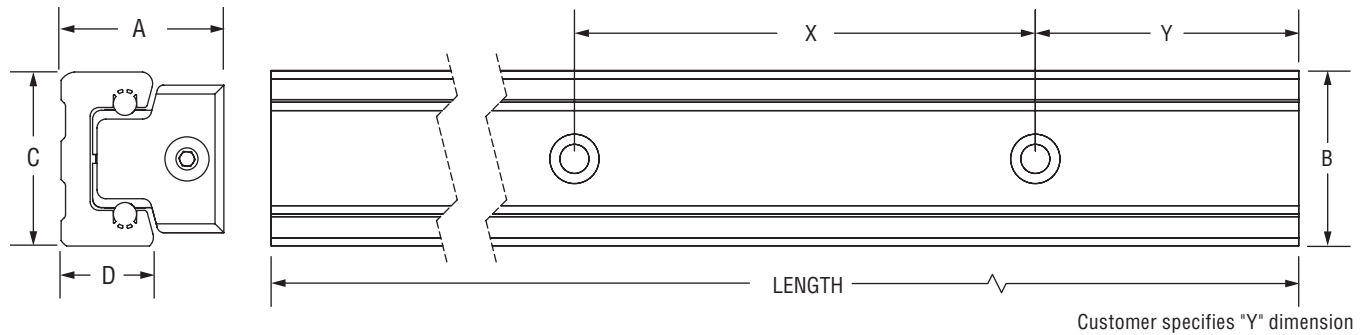

ISO Metric Series

Linear Guides **Redi-Rail®****RAIL DIMENSIONS****DIMENSIONAL INFORMATION** mm

| PART NO. | X | B | MOUNTING HOLES | WEIGHT KG/M |
|----------|----|----|----------------|----------------|
| RR30 | 60 | 30 | M5 BHCS | 0.868 |
| RR45 | 60 | 45 | M6 BHCS | 1.718 |
| RR65 | 80 | 65 | M6 BHCS | 3.758 |

NOTE: Rail lengths are available up to 6 m. Y dimension is specified by customer at time of order. If Y is not specified, holes are centered on length of rail.

ROLLER/SHAFT INTERFACE

- **GOTHIC ARCH CONTACT** for smooth, high speed performance

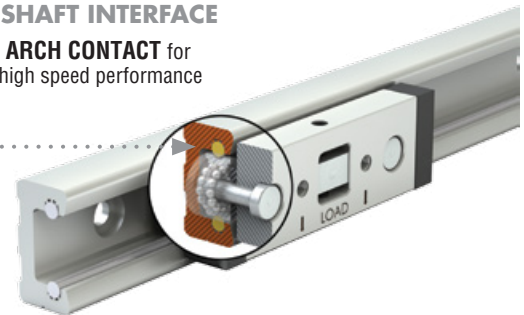

[Download CAD](#)

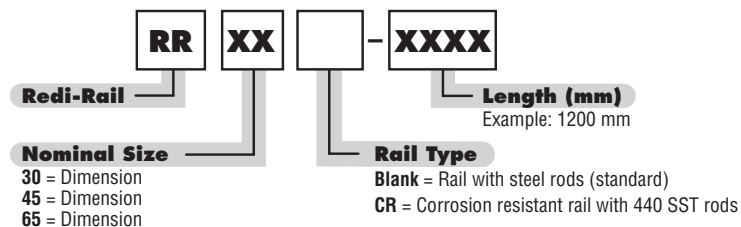
RAIL ORDERING INFORMATION

Ordering example: RR65-1200; Y = 20 mm.
Specify Y dimension (hole to end) at time of order.



Redi-Rail® Linear Guides

Inch Series

SLIDE DIMENSIONS

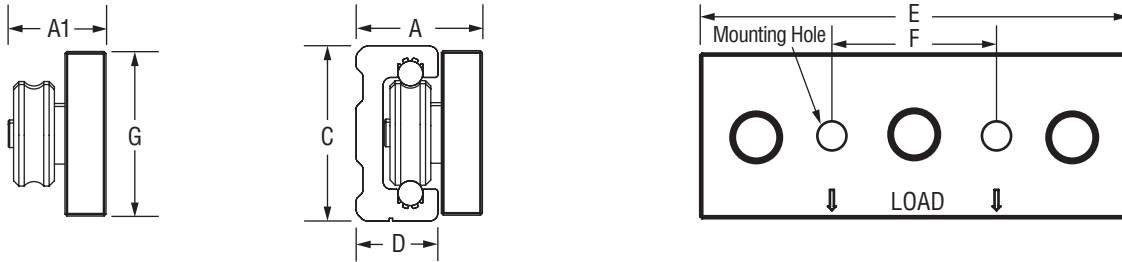

- **SEALED ROLLER**
Ideal around contaminants
- **DOUBLE ROW BEARING**
High speed & acceleration.

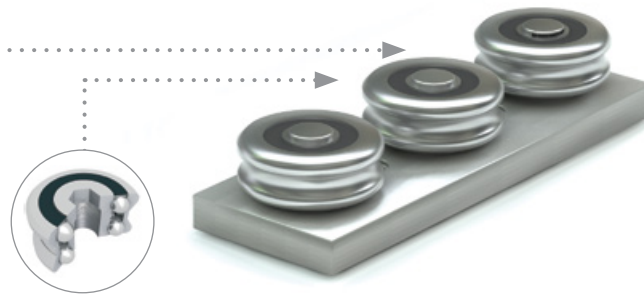

DIMENSIONAL INFORMATION inches

| PART NO. | A1 | A | G | C | D | E | F | MOUNTING HOLES | WEIGHT LBS. |
|----------|-------|-------|------|-------|------|------|-------|----------------|-------------|
| RRS14 | 0.702 | 0.959 | 1.25 | 1.33 | 0.62 | 3.25 | 1.25 | 1/4-28 | 0.25 |
| RRS18 | 0.823 | 1.134 | 1.50 | 1.921 | 0.76 | 4.50 | 1.625 | 5/16-24 | 0.50 |

LOAD RATINGS

| PART NO. | Fd | Fy | Fz | Mx | My | Mz |
|----------|------|-----|-----|--------|--------|--------|
| | LBS | LBS | LBS | IN-LBS | IN-LBS | IN-LBS |
| RRS14 | 421 | 340 | 79 | 21 | 54 | 201 |
| RRS18 | 1032 | 850 | 168 | 67 | 153 | 677 |

 [Download CAD](#)

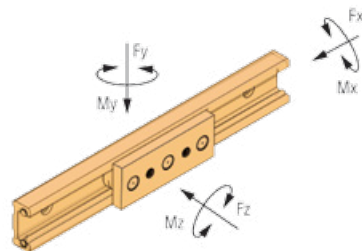

Fd = Dynamic capacity (LC)
Fz = Axial capacity
Fy = Radial capacity
Mx, My, Mz = Moment capacities

Conversions

newton (N) x 0.2248 = lbs.
(lbf) meter x 0.0397 = inch
newton - meter (N-m) x 8.851 = in.-lbs.

SLIDE ORDERING INFORMATION

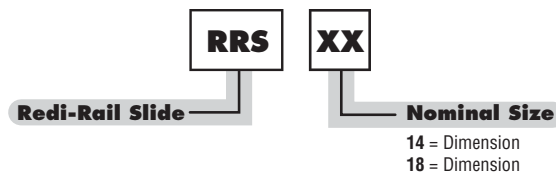

REDI-RAIL
COMMERCIAL RAIL
HARDENED CROWN ROLLER
V-GUIDE
HEVI-RAIL

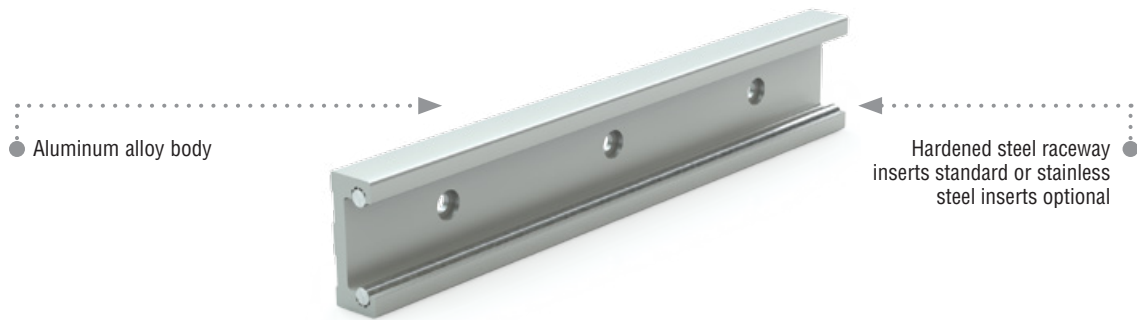
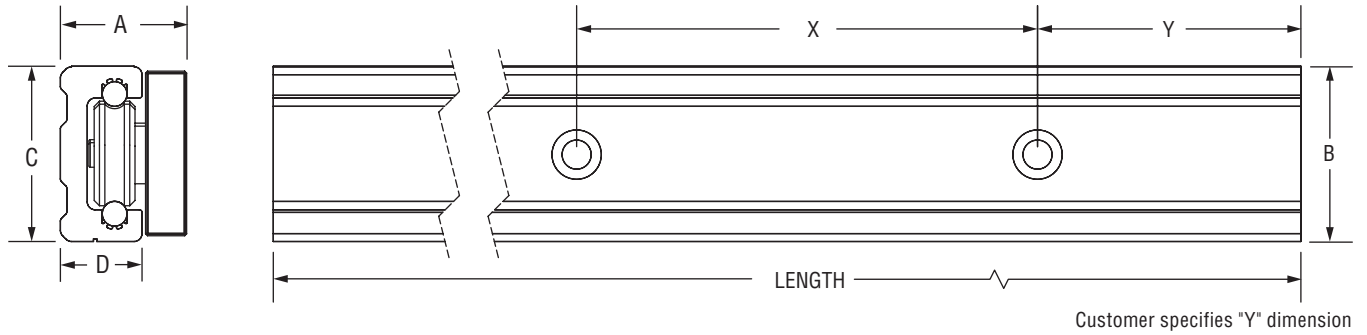

Inch Series

Linear Guides **Redi-Rail®****RAIL DIMENSIONS****DIMENSIONAL INFORMATION** inches

| PART NO. | X | B | MOUNTING HOLES | WEIGHT LBS/FT |
|----------|-----|------|----------------|------------------|
| RR14 | 3.5 | 1.32 | #10 BHCS | 0.56 |
| RR18 | 3.5 | 1.91 | 1/4" BHCS | 0.85 |

NOTE: Rail lengths are available up to 19' (6 m). Y dimension is specified by customer at time of order. If Y is not specified, holes are centered on length of rail.

ROLLER/SHAFT INTERFACE

- **GOTHIC ARCH CONTACT** for smooth, high speed performance

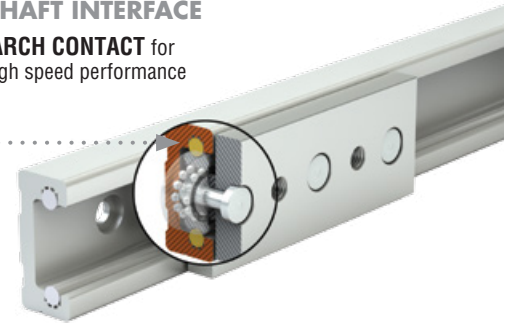

Download CAD

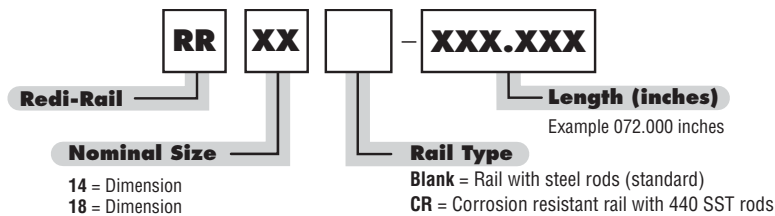
RAIL ORDERING INFORMATION

Ordering example: RR18-072.000; Y = 2 inches.
Specify Y dimension (hole to end) at time of order.

REDI-RAIL

COMMERCIAL RAIL

HARDENED CROWN ROLLER

V-GUIDE

HEVI-RAIL



Redi-Rail® Linear Guides

Low Profile

SLIDE DIMENSIONS

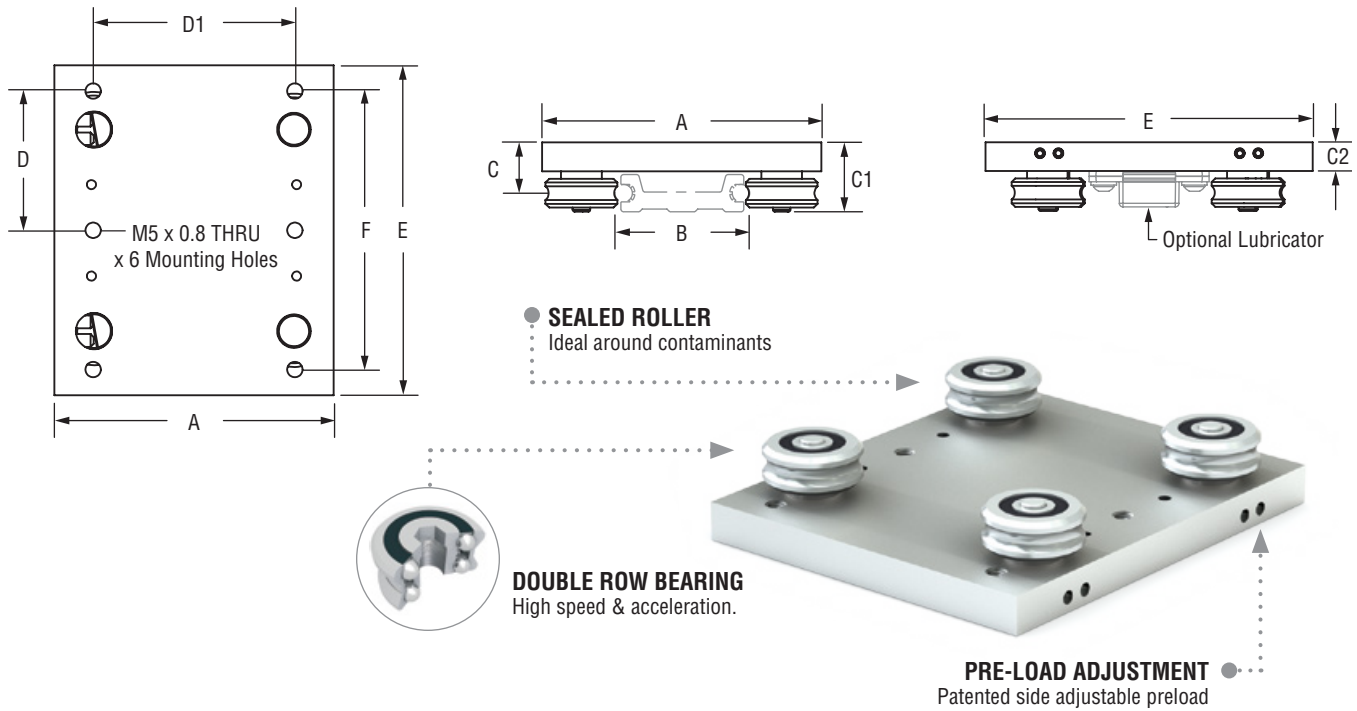

DIMENSIONAL INFORMATION mm

| PART NO. | A | B | C | C1 | C2 | D | D1 | E | F | MOUNTING HOLES | WEIGHT LBS. |
|----------|------|------|------|----|-----|----|----|----|----|-------------------|-------------|
| RRL34C | 76.2 | 36.8 | 13.9 | 19 | 7.9 | 38 | 55 | 90 | 76 | M5 x 0.8 THRU x 6 | 0.5 |

LOAD RATINGS

| PART NO. | Fy | | Fz | | Mx | | My | | Mz | |
|----------|------|-----|-----|-----|-----|--------|-----|--------|-----|--------|
| | N | LBS | N | LBS | N-M | IN/LBS | N-M | IN/LBS | N-M | IN/LBS |
| RRL34C | 1220 | 270 | 510 | 110 | 14 | 120 | 31 | 270 | 13 | 110 |

[Download CAD](#)

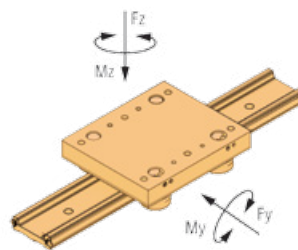

Fd = Dynamic capacity (LC)
Fz = Axial capacity
Fy = Radial capacity
Mx, My, Mz = Moment capacities

Conversions

newton (N) x 0.2248 = lbs.
(lbf) meter x 0.0397 = inch
newton - meter (N-m) x 8.851 = in.-lbs.

SLIDE ORDERING INFORMATION

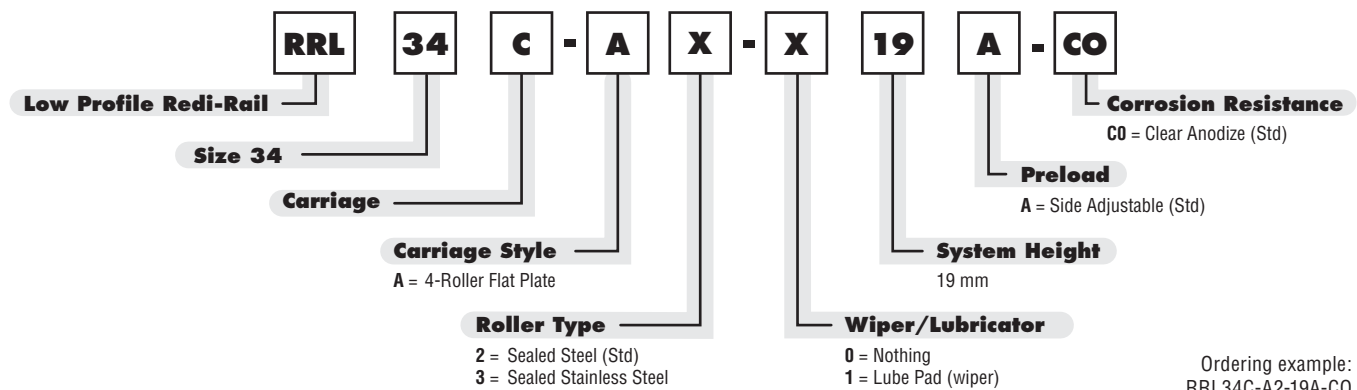



Low Profile

Linear Guides **Redi-Rail®**

RAIL DIMENSIONS

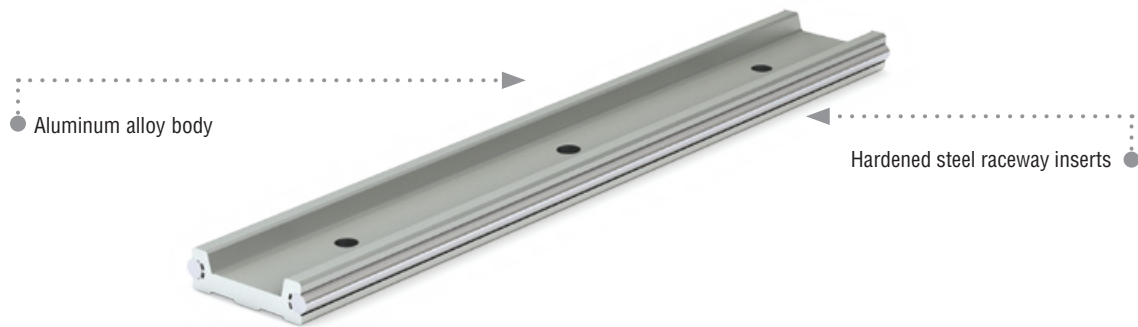
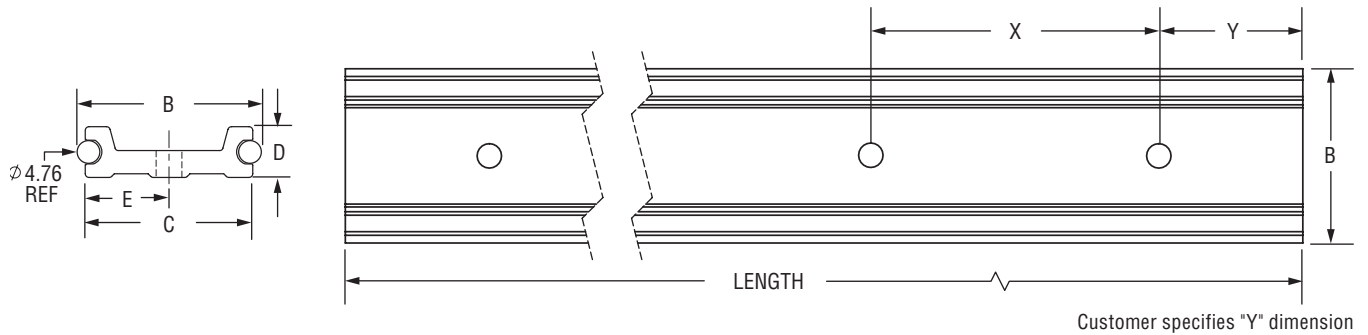

DIMENSIONAL INFORMATION mm

| PART NO. | B | C | D | E | X | MOUNTING HOLES | WEIGHT KG/M |
|----------|------|------|------|------|----|----------------|-------------|
| RRL34 | 36.8 | 33.5 | 10.2 | 16.8 | 80 | M5 BHCS | 0.032 |

NOTE: Rail lengths are available up to 10 ft (3048 mm). Y dimension is specified by customer at time of order. If Y is not specified, holes are centered on length of rail.

ROLLER/SHAFT INTERFACE

● **GOTHIC ARCH CONTACT** for smooth, high speed performance

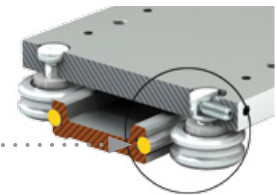
[Download CAD](#)

RAIL ORDERING INFORMATION

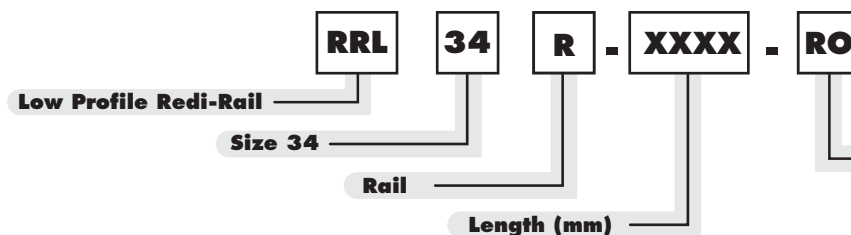

Corrosion Resistance

R0 = Clear anodize aluminum rail w/RC60 steel shafting (Std)

Optional

R1 = Clear anodize aluminum rail w/stainless shafting

R2 = Electroless nickel plate rail w/stainless shafting

R3 = FDA compliant anti-microbial w/powder coated stainless shafting

Ordering example: RRL34R-1200-R0; Y = 20 mm.
Specify Y dimension (hole to end) at time of order.



Redi-Rail® Linear Guides

- Sealed double row bearings provide smooth linear guidance that is maintenance free
- Side adjusted preload simplifies assembly and installation
- Operating temperature range -20°C to 80°C (-4°F to 176°F)
- Butt-joinable for longer lengths
- Available in Inch or ISO Metric



[Link to technical information—page 65](#)

ADJUSTING SLIDE PRELOAD

Slide preload is initially set by the factory. If further adjustments are needed, here are some simple steps to follow.

Metric Series

1. To loosen the eccentric (center) roller, use an allen wrench to loosen the screw that is on the side of the mounting block. Be sure to loosen the screw that is on the side of the direction you want the roller to move.
2. When it is loose, tighten the set screw on the opposite side of the block. This will move the roller and mounting stud.
3. Make a very small change, retighten the first set screw, and try it out. If the preload is too loose, you will feel the slider rock and you will hear a slight “clunk.” If it is too tight, the slider will roll rough, like riding a bicycle on a gravel road.
4. Move the slide along the length of the rail by hand. Adjust it so that it does not feel loose anywhere. It may take you several times to get the proper adjustment.
5. Make sure the rollers are tightened with the proper adjustment prior to operation. It is recommended to lock the set screws in place with a breakable threadlocker so they will hold position and minimize any effects of vibration.

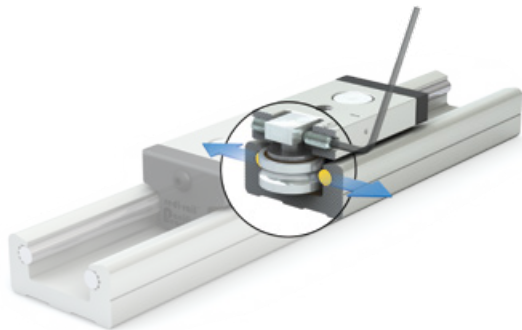

MOUNTING SLIDER BODY & MAX CAPACITY

The table shows recommended bolt tightening torques for mounting to the slide body. Be sure to use bolts that are long enough to obtain full thread engagement.



LUBRICATION - RAILS & BEARINGS

Redi-Rail rollers are internally lubricated for life, but the rails must always have a layer of grease. As a guideline, reapply fresh grease every 50,000 cycles. PBC Linear recommends white lithium based grease.

SLIDER ORIENTATION

The 3-roller slide should be installed in the rail so the load is shared on the two outside rollers. The orientation marks indicate how to align the slider with the load direction.



MOUNTING TORQUE

| PART NUMBER | IN-LBS. TORQUE | NM TORQUE |
|----------------|----------------|-----------|
| RRS14 RRS30 | 25 | 3 |
| RRS18 RRS45 | 70 | 8 |
| RRS65 | 150 | 24 |

REDI-RAIL
COMMERCIAL RAIL
HARDENED CROWN ROLLER
V-GUIDE
HEVI-RAIL



Linear Guides **Redi-Rail®**

LIFE CALCULATIONS

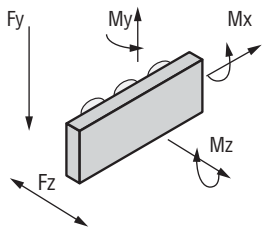

Fd = Dynamic capacity (LC)
 Fz = Axial capacity
 Fy = Radial capacity
 Mx, My, Mz = Moment capacities

Conversions

newton (N) x 0.2248 = lbs.
 (lbf) meter x 0.0397 = inch
 newton - meter (N-m) x 8.851 = in.-lbs.

| PART NO. | RADIAL Fy | AXIAL Fz | Mx | My | Mz |
|---------------|-----------|----------|-----------|-----------|-----------|
| INCH | LBS | LBS | IN-LBS | IN-LBS | IN-LBS |
| RRS14 | 336 | 79 | 21 | 54 | 201 |
| RRS18 | 847 | 168 | 67 | 153 | 677 |
| METRIC | N | N | Nm | Nm | Nm |
| RRS30 | 1002 | 330 | 1.8 | 5.5 | 12.5 |
| RRS45 | 2660 | 827 | 6.6 | 19.9 | 47.9 |
| RRS65 | 5950 | 1,678 | 19.0 | 58.2 | 154.7 |

To calculate an approximate life for Redi-Rail sliders, use the following equation.

Inch Series

$$L_{RR} = 10^7 \cdot (Fd / (\text{Load}_{\text{Equiv}} \cdot RF))^{3.0} \text{ (inches)}$$

Fd = Slider Life Capacity which is found in the table

Load_{Equiv} = Equivalent Radial Load found from the following equation:

$$\text{Load}_{\text{Equiv}} = Fy \cdot \left(\frac{\text{Load}_{\text{Axial}}}{Fz} + \frac{Mx}{Mx \text{ Max}} + \frac{My}{My \text{ Max}} + \frac{Mz}{Mz \text{ Max}} \right) + \text{Load}_{\text{Radial}}$$

| PART NO. | MAX SPEED FPM | MAX SPEED IPM | Fd |
|----------|---------------|---------------|------|
| RRS14 | 500 | 6000 | 421 |
| RRS18 | 800 | 9,600 | 1032 |

Metric Series

$$L_{RR} = (Fd / \text{Load}_{\text{Equiv}} \cdot RF)^{3.0} \times 100,000 \text{ (meters)}$$

Fd = Slider Life Capacity which is found in the table

Load_{Equiv} = Equivalent Radial Load found from the following equation:

$$\text{Load}_{\text{Equiv}} = Fy \cdot \left(\frac{\text{Load}_{\text{Axial}}}{Fz} + \frac{Mx}{Mx \text{ Max}} + \frac{My}{My \text{ Max}} + \frac{Mz}{Mz \text{ Max}} \right) + \text{Load}_{\text{Radial}}$$

| PART NUMBER | MAX SPEED m/min | MAX SPEED m/s | Fd N |
|-------------|-----------------|---------------|-------|
| RR30 | 300 | 5.0 | 1440 |
| RR45 | 420 | 7.0 | 4404 |
| RR65 | 480 | 8.0 | 10200 |

Note: Reduction factors apply to both inch and metric series

- RF = Reduction Factor of the application or environment
- = 1.0 to 1.5 for very clean, low speed (<30% max), low shocks
 - = 1.5 to 2.0 or some dirt, moderate speed (30% max to 75% max), medium shocks and vibration
 - = 2.0 to 3.0 for heavy dirt and dust, high speeds (>75% max) and heavy shocks and vibration

LOAD COMPARISON

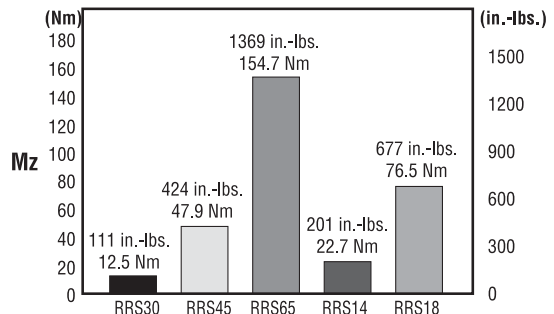
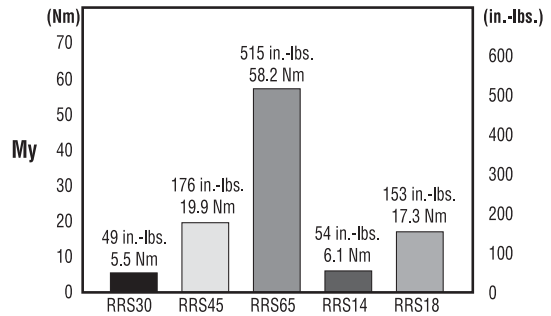
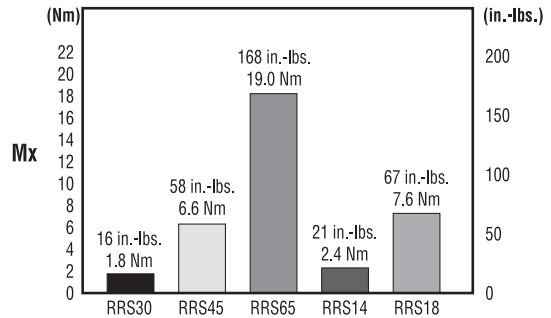
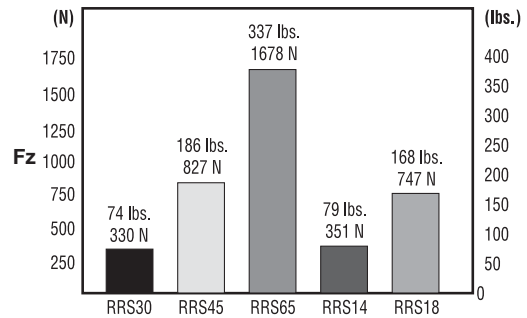
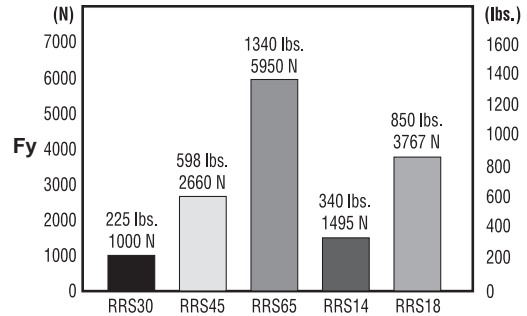

REDI-RAIL
COMMERCIAL RAIL
HARDENED CROWN ROLLER
V-GUIDE
HEVI-RAIL



Commercial Rail Linear Guides

| | SLIDER | # OF ROLLERS | Fd | Fy | Fz |
|-----------------|--------|--------------|------------------|--------|-------|
| | | | DYNAMIC CAPACITY | RADIAL | AXIAL |
| | | | N | N | N |
| STEEL | CR20 | 3 | 280 | 210 | 160 |
| | CR30 | 3 | 800 | 610 | 420 |
| | CR45 | 3 | 1740 | 1330 | 930 |
| STAINLESS STEEL | CRSS20 | 3 | 280 | 210 | 160 |
| | CRSS30 | 3 | 800 | 610 | 420 |
| | CRSS45 | 3 | 1740 | 1330 | 930 |

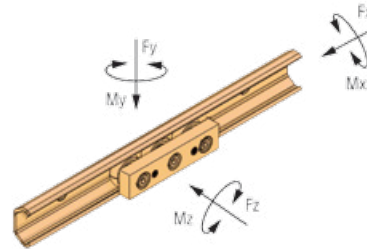

Fd = Dynamic capacity (LC)
 Fz = Axial capacity
 Fy = Radial capacity
 Mx, My, Mz = Moment capacities

Conversions

newton (N) x 0.2248 = lbs.
 (lbf) meter x 0.0397 = inch
 newton - meter (N-m) x 8.851 = in.-lbs.

FEATURES & BENEFITS

Commercial Rail is a simple and cost effective linear motion solution with high load capacity and corrosion resistance.

- Precision formed rails available in zinc plated carbon steel, or stainless steel
- Speeds up to 1.5 m/s (59 in/s)
- Withstands temperatures up to 100°C (212°F)
- Load capability up to 1330 N (298 lbs)

[Link to technical information—page 65](#)

● **ROLL FORMED RAIL**
 Is corrosion resistant

● **SEALED ROLLER**
 Ideal around contaminants

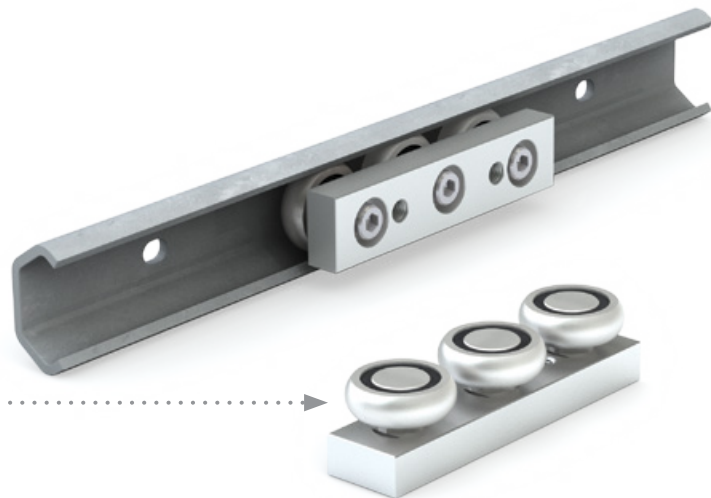

1:1 SCALE

Dimensions shown in mm

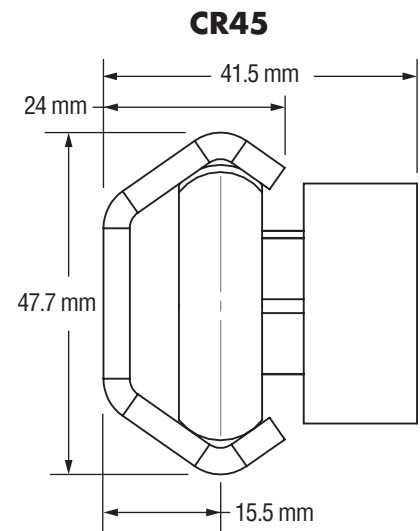
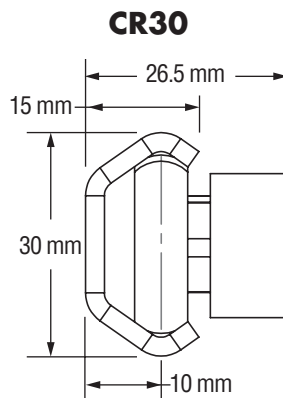
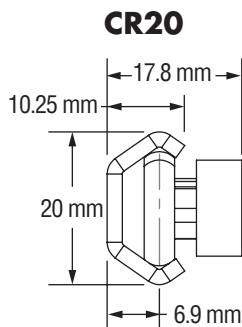



Linear Guides **Commercial Rail**

PRODUCT OVERVIEW

Commercial Rail is a simple and cost effective linear motion solution with high load capacity and corrosion resistance.

- Roll formed rails made of steel/stainless steel sheet for low cost and corrosion resistance application
- Zinc plated rail length up to 6000 mm
- Machined slider body made of aluminum alloy and anodized for corrosion resistance
- Steel rollers are made of 52100 chrome steel, hardened and ground, lubricated for life and sealed against contamination
- Stainless steel rollers made of 440C stainless steel for better corrosion resistance, lubricated for life and sealed against contamination
- Rollers made with thread integrated inner ring for ease of assembly and adjustment of preload
- Custom polymer wipers can be designed and manufactured to improve the smoothness of motion and service life
- Maximum operating temperature 100°C (212°F)



[Link to temperature information—page 65](#)

- Consult with factory for special hole spacing
- Speed up to 1.5 m/s
- Moment loads should be carried by two slides or two parallel rollers

MATERIAL & FINISH SPECIFICATIONS

| | CR SERIES RAIL | SS SERIES RAIL |
|-----------------|---------------------------------|---------------------------|
| Rail | Carbon steel sheet, Zinc plated | Stainless steel 304 sheet |
| Slide | Aluminum alloy anodized | Aluminum alloy anodized |
| Rollers | Chrome steel or Polymer | Stainless steel |
| Hardware | Steel zinc plated | Stainless steel 18-8 |

SLIDE ORIENTATION

The 3-roller slide should be installed in the rail so that the load is shared among the two outside rollers. The orientation marks indicate how to align the slider with the load direction.

- Custom polymer wipers can be designed and manufactured to improve the smoothness of motion and service life
- Consult with factory for special hole spacing
- Moment loads should be carried by two slides or two parallel rollers

LUBRICATION – RAILS & BEARINGS

The rollers are internally lubricated for life, but the rails must always have a layer of grease. As a guideline, reapply fresh grease every 50,000 cycles.

PRELOAD ADJUSTMENT

- To loosen the center roller, use an Allen wrench to untighten the screw while holding the roller still with an open-end wrench
- Turn the center roller to a position to achieve the desired preload
- Move the slide along the length of the rail by hand. Adjust it so that it does not feel loose anywhere.
- Tighten the screw while holding the roller flat with an open-end wrench

| PRELOAD ADJUSTMENT | CR20/CRSS20 | CR30/CRSS30 | CR45/CRSS45 |
|-----------------------------|-------------|-------------|-------------|
| Wrench flat sq. (mm) | 6 | 10 | 14 |



[Email an Application Engineer](#)



[Link to video "How to Specify Length Products"](#)

MOUNTING

| SLIDE | CR20/CRSS20 | CR30/CRSS30 | CR45/CRSS45 |
|---|-------------|-------------|-------------|
| Slide mount screws (Socket head cap) | M5 | M6 | M8 |
| Tightening torque (IN/LBS) | 25 | 43 | 103 |
| Tightening torque (N-m) | 3 | 5 | 12 |

| RAIL | | | | | |
|-----------|--------|--------|--------------------------------------|--------------|------|
| CLEARANCE | | | SUGGESTED FASTENER (Button head cap) | HEAD HEIGHT* | |
| SIZE | INCHES | MM | | INCHES | MM |
| CR20 | 0.115 | 2.921 | M4 | 0.087 | 2.2 |
| CR30 | 0.158 | 4.0132 | M5 | 0.108 | 2.75 |
| CR45 | 0.256 | 6.5024 | M8 | 0.433 | 11 |

* Head height dimensions meet ISO 7380

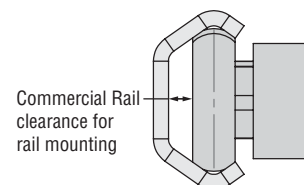



Commercial Rail Linear Guides

SLIDE DIMENSIONS

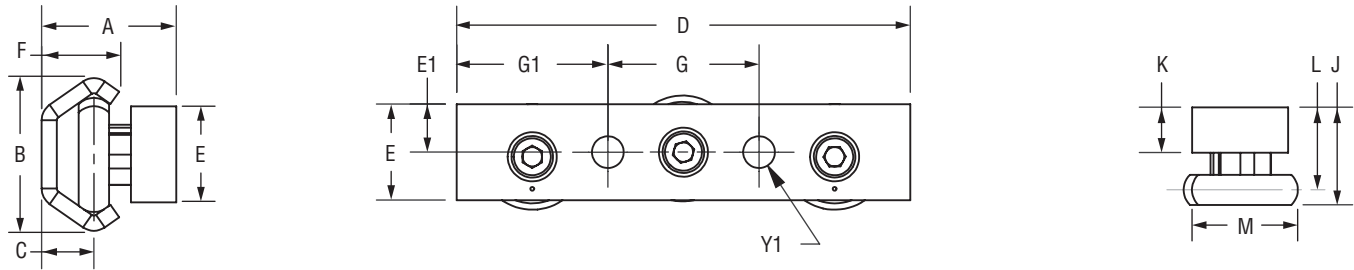

● **SEALED ROLLER**
Ideal around contaminants

● **MACHINED BODY**
Anodized aluminum alloy

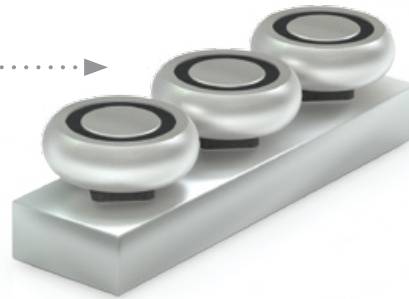

DIMENSIONAL INFORMATION mm

| PART NO. | A | B | C | D | E | F | G | G1 | J | K | L | M Ø REF | Y1 | THREAD PITCH | WEIGHT LBS. |
|----------|------|------|------|-----|------|-------|----|------|------|----|------|---------|-------------------|--------------|-------------|
| CR20 | 17.8 | 20 | 6.9 | 60 | 12.7 | 10.25 | 20 | 20 | 12.9 | 6 | 10.9 | 14 | 2x Ø 4.2 thru all | M5 x 0.8 | 1.10 |
| CR30 | 26.5 | 30 | 10 | 80 | 19.1 | 15 | 35 | 22.5 | 20 | 10 | 16.5 | 22.8 | 2x Ø 5.0 thru all | M6 x 1.0 | 0.25 |
| CR45 | 41.5 | 45.7 | 15.5 | 120 | 31.8 | 24 | 50 | 35 | 31.5 | 15 | 26 | 35.5 | 2x Ø 6.8 thru all | M8 x 1.25 | 0.90 |

LOAD RATINGS

| PART NO. | | Fd DYNAMIC CAPACITY N | Fy RADIAL N | Fz AXIAL N |
|-----------------|--------|-----------------------|-------------|------------|
| STEEL | CR20 | 280 | 210 | 160 |
| | CR30 | 800 | 610 | 420 |
| | CR45 | 1740 | 1330 | 930 |
| STAINLESS STEEL | CRSS20 | 280 | 210 | 160 |
| | CRSS30 | 800 | 610 | 420 |
| | CRSS45 | 1740 | 1330 | 930 |

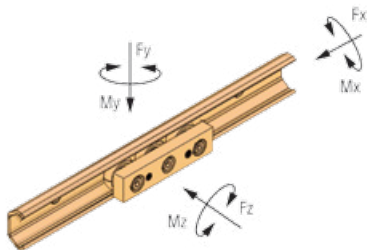

Fd = Dynamic capacity (LC)
Fz = Axial capacity
Fy = Radial capacity
Mx, My, Mz = Moment capacities

Conversions
newton (N) x 0.2248 = lbs.
(lbf) meter x 0.0397 = inch
newton - meter (N-m) x 8.851 = in.-lbs.

SLIDE ORDERING INFORMATION

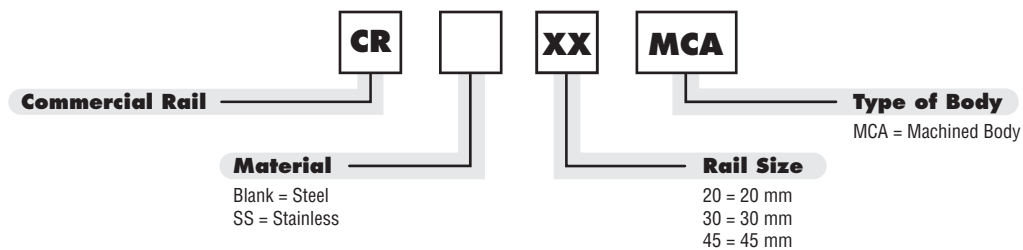

Download CAD

Ordering example: CR20MCA

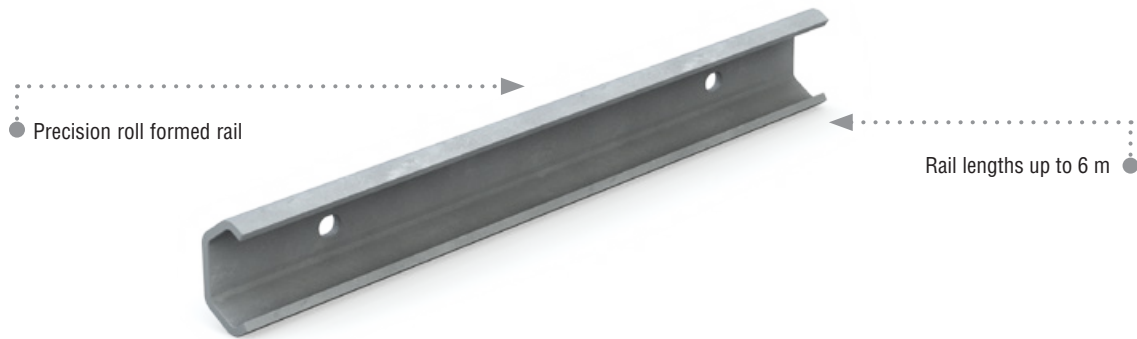
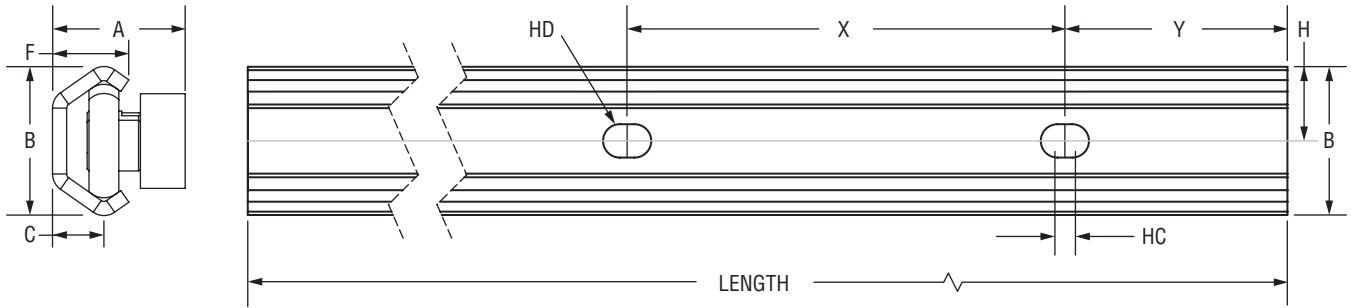
Linear Guides **Commercial Rail****RAIL DIMENSIONS****DIMENSIONAL INFORMATION mm**

| PART NO. | A | B | C | F | H | HC | HD | X | Y | RAIL WT. |
|----------|------|------|------|-------|------|----|-----|----|----|----------|
| | MM | MM | MM | MM | MM | MM | MM | MM | MM | LBS./FT. |
| CR20 | 17.8 | 20 | 6.9 | 10.25 | 10.0 | 2 | 4.5 | 80 | 40 | 0.31 |
| CR30 | 26.5 | 30 | 10 | 15 | 15.0 | 2 | 5.5 | 80 | 40 | 0.64 |
| CR45 | 41.5 | 45.7 | 15.5 | 24 | 22.9 | 2 | 9.0 | 80 | 40 | 1.31 |

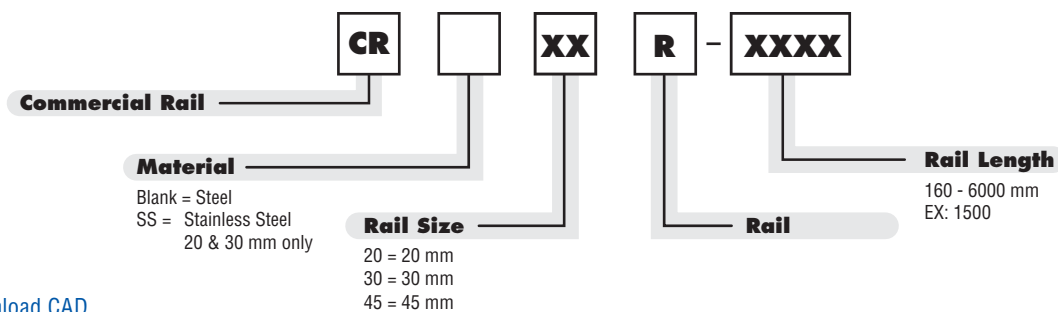
RAIL ORDERING INFORMATION

Ordering example: CR20R-1500

REDI-RAIL

COMMERCIAL RAIL

HARDENED CROWN ROLLER

V-GUIDE

HEVI-RAIL



Hardened Crown Rollers

FEATURES & BENEFITS

Hardened crown rollers are a superb choice for low-cost linear motion. The rollers come pre-assembled and are self-aligning for simple installation. Hardened crown rollers are great for point-to-point applications, and ensure strong, sturdy and long-lasting linear motion.

- Precision rolling element bearing riding in a Cooper B-Line Series rail
- 9/16" Hex head for easier mounting
- Available with either a 5/16 x 18 or M8 thread
- Maximum wheel bearing load up to 1334 N (300 lbs)
- Maximum speed up to 762 mm/s (30 in/s)
- Rails available up to 3 m (10 ft) in steel or powder coated finish. Contact manufacturer for longer lengths.

ACCESSORIES AVAILABLE:

- Angle brackets (for welding to mounting rail)
- End stops

● **COOPER B-LINE SERIES**
 Rail in steel or powder coated finish

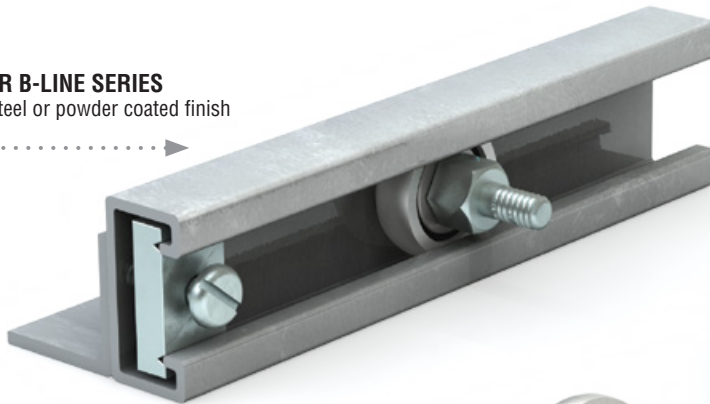

● **PRE-ASSEMBLED**
 Roller



● **END STOPS**

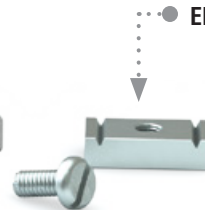

● **ANGLE BRACKETS**
 For welding to mounting rail



ORDERING INFORMATION

| PART NO. | DESCRIPTION |
|----------|--|
| PAC3016 | Hardened Crown Roller Bearing |
| PAC3016M | Hardened Crown Roller Bearing with metric thread |
| PAC2245 | Rail System - unpainted (specify length - priced per foot) |
| PAC2247 | Rail System - black powder coat finish (specify length - price per foot) |
| PAC2244 | Angle Brackets - 1" Steel |
| PAC2246 | End Stops for Rail System (bolt included) |



REDI-RAIL
 COMMERCIAL RAIL
 HARDENED CROWN ROLLER
 V-GUIDE
 HEVI-RAIL



Hardened Crown Rollers

1:1 SCALE BEARINGS

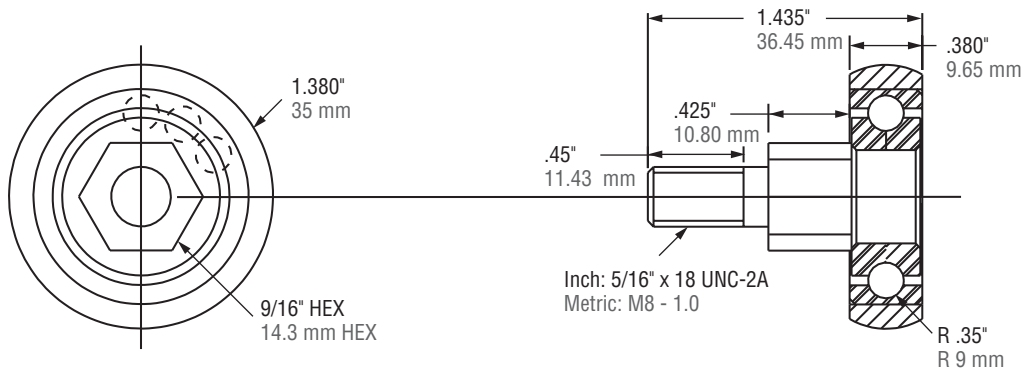

RAILS

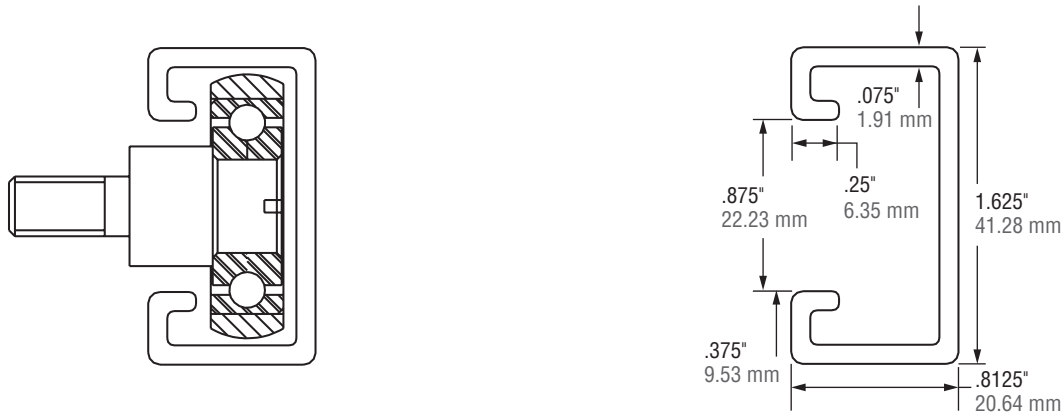

ANGLE BRACKET

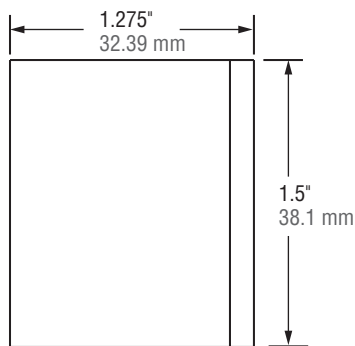

Angle brackets can be welded in any position along the length of the track

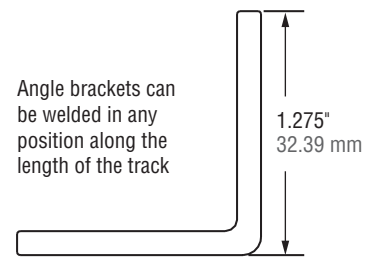

END STOP

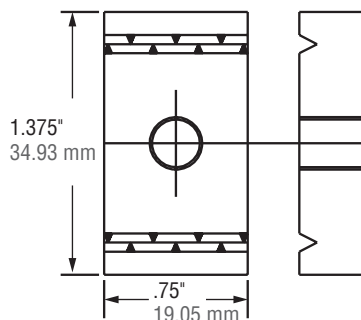

Note: All metric dimensions are conversions from inch dimensions. All parts are manufactured to inch standards. See ordering information on the previous page.



V-Guide Wheels, Rails, & Bushings

| V GUIDE WHEEL | | SIZE | | PER WHEEL | | | | | |
|---------------|-----|------|-------|-----------|------|-------------|------|------------|-----|
| | | | | WEIGHT | | RADIAL LOAD | | AXIAL LOAD | |
| | | MM | IN | G | OZ | N | LBS | N | LBS |
| Size 1 | VW1 | 20 | 3/4 | 12 | 0.42 | 1260 | 283 | 297 | 67 |
| Size 2 | VW2 | 30 | 1 1/4 | 40 | 1.41 | 2730 | 614 | 632 | 142 |
| Size 3 | VW3 | 45 | 1 3/4 | 136 | 4.79 | 6166 | 1386 | 1448 | 326 |
| Size 4 | VW4 | 60 | 2 1/4 | 285 | 10 | 9991 | 2246 | 2313 | 520 |

FEATURES & BENEFITS

V-Guide systems are an industry standard for linear motion, and offer features that make them an ideal solution for a wide range of motion control applications.

- Radial loads up to 9.9 N (2246 lbs) per wheel
- Axial loads up to 2.3 N (520 lbs) per wheel
- Precision dual row angular contact design
- Operating temperature range -20°C to 80°C (-4°F to 176°F)
- Concentric or eccentric wheel bushings in inch & metric sizing



[Link to technical information—page 65](#)

V-GUIDE WHEELS

V-Guide wheels are precision ground dual row angular contact ball bearings with hardened outer way surfaces that provide low friction guidance for linear motion applications. They can be used with internal or external 90-degree ways – or used with round shafts.

- Four (4) sizes
- Permanently sealed and lubricated
- Precision dual row bearing construction
- Available in 52100 bearing steel or 420 stainless steel construction
- 304 stainless steel shields or nitrile rubber seals

V-GUIDE RAIL

Rails are induction hardened, ground and polished. The track body is left soft for easy drilling of mounting holes. Four sizes are designed to correspond with wheel sizes.

- Has shoulder for simple mounting and alignment
- Induction hardened way surface
- 1045 carbon steel or 400 series stainless steel
- Optional black oxide finish
- Rails are cut to length, max length up to 6 m (19 ft)

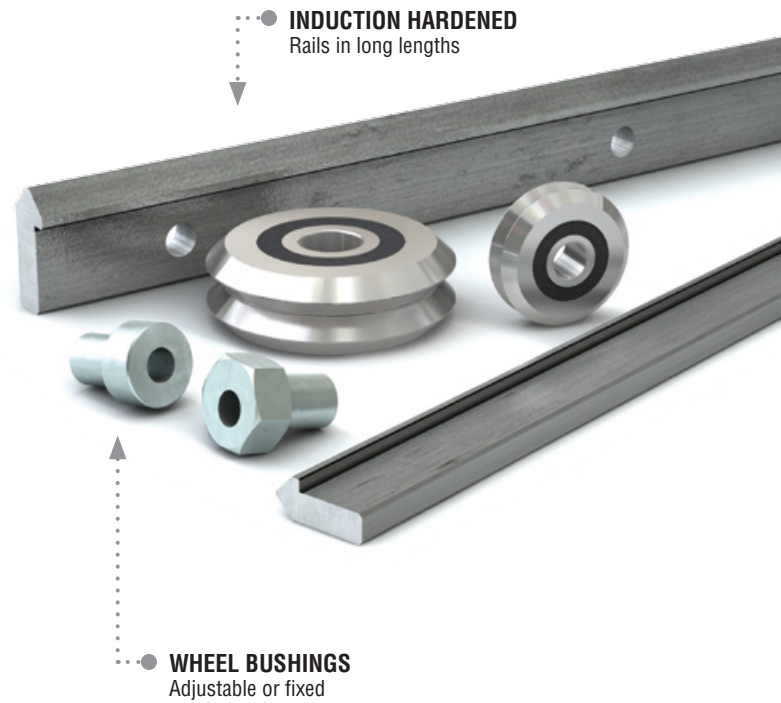

WHEEL BUSHINGS

- 303 stainless steel construction
- Inch or metric hardware
- Adjustable bushings allow adjustable fit and preload
- Fixed bushings are used in the primary radial load direction

REDI-RAIL
COMMERCIAL RAIL
HARDENED CROWN ROLLER
V-GUIDE
HEVI-RAIL



Wheels, Rails, & Bushings **V-Guide**

1:1 SCALE

SIZE 1: VW1

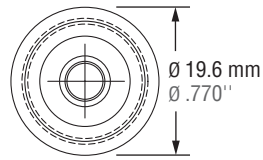
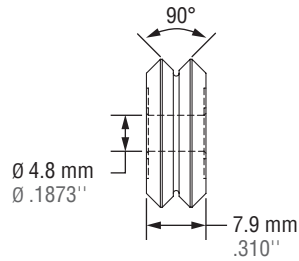

SIZE 2: VW2

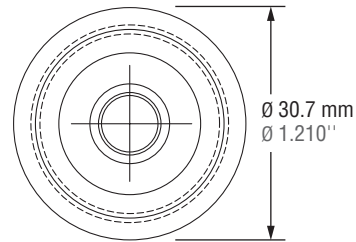
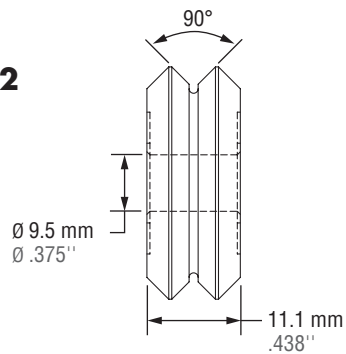

SIZE 3: VW3

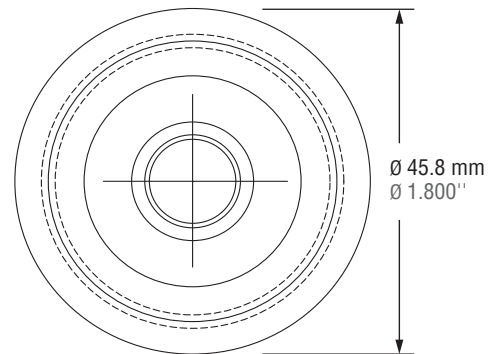
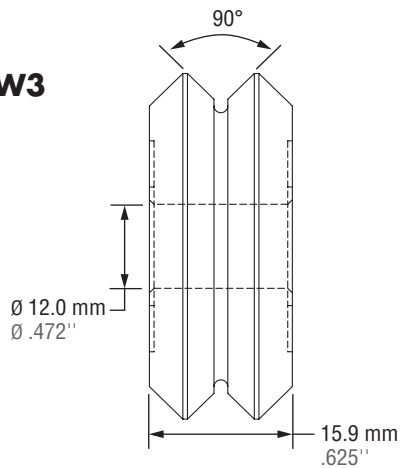

SIZE 4: VW4

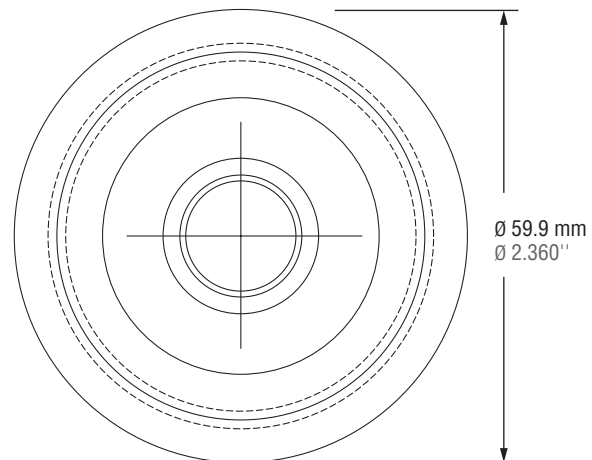
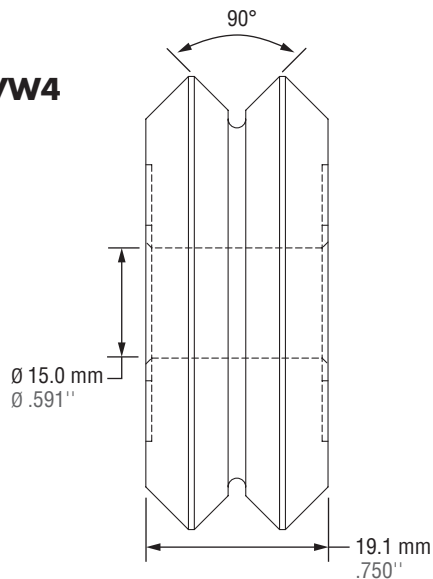

REDI-RAIL

COMMERCIAL RAIL

HARDENED CROWN ROLLER

V-GUIDE

HEVI-RAIL



V-Guide Size 1

20 mm (3/4")

Radial loads to 283 lbs. (1260 N) per wheel
 Axial loads to 67 lbs. (297 N) per wheel
 Wheel weight: .42 oz. (12 g)

V-GUIDE WHEELS

| | |
|--------------|--------------------------|
| VW1 | Shielded Bearing |
| VWS1 | Sealed Bearing |
| VWSS1 | Sealed Stainless Bearing |

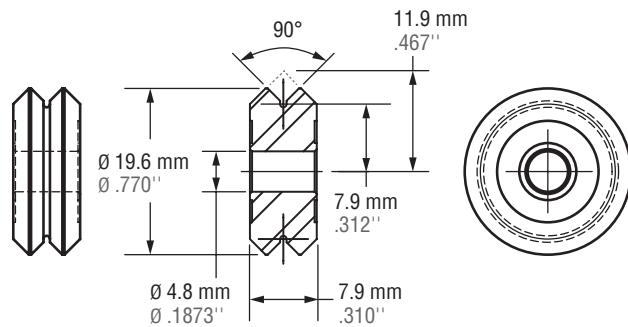

Download CAD

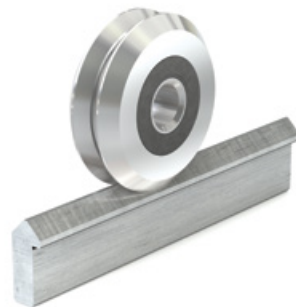

WHEEL BUSHINGS

| INCH SERIES | |
|---------------|-------------------------------------|
| VB1 | Concentric Fixed Bushing |
| VBA1 | Eccentric Adjustable Bushing |
| METRIC SERIES | |
| MVB1 | Concentric Metric Fixed Bushing |
| MVBA1 | Eccentric Metric Adjustable Bushing |

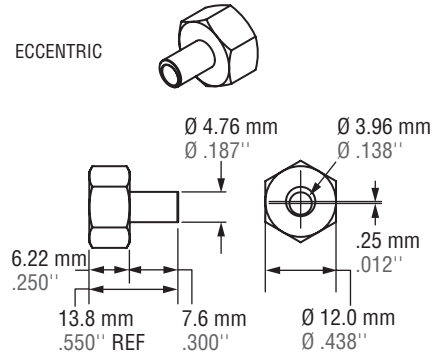
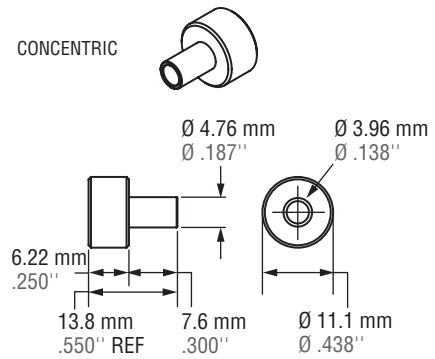

V-GUIDE RAIL

| CARBON STEEL | | STAINLESS STEEL | |
|-----------------|--|------------------|---|
| VR1-xxx | undrilled rail max. length 21' (6400 mm) | VRS1-xxx | undrilled rail, max. length 21' (6400 mm) |
| VRD1-xxx | drilled rail | VRSD1-xxx | drilled rail |

Note: Non-heat treated rails available in all sizes, contact factory.

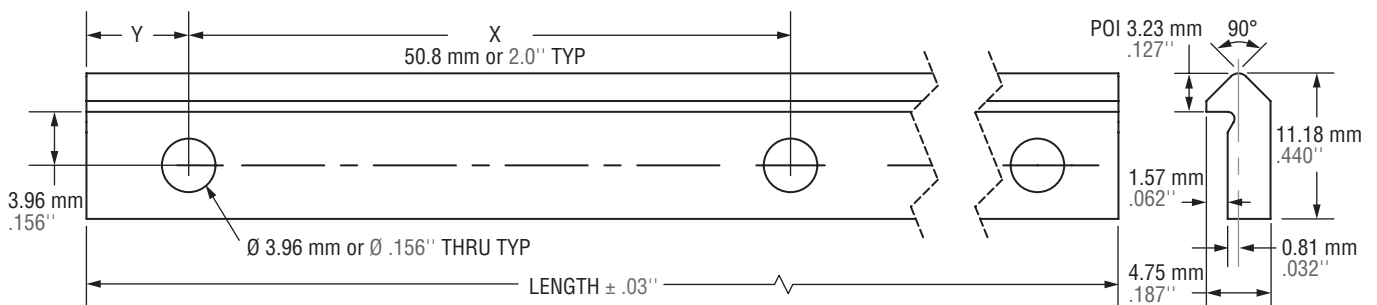

Specify Y dimension (hole to end) at time of order.



30 mm (1-1/4")

Size 2 V-Guide

Radial loads to 614 lbs. (2730 N) per wheel
 Axial loads to 142 lbs. (632 N) per wheel
 Wheel weight: 1.3 oz. (38 g)

V-GUIDE WHEELS

| | |
|--------------|--------------------------|
| VW2 | Shielded Bearing |
| VWS2 | Sealed Bearing |
| VWSS2 | Sealed Stainless Bearing |

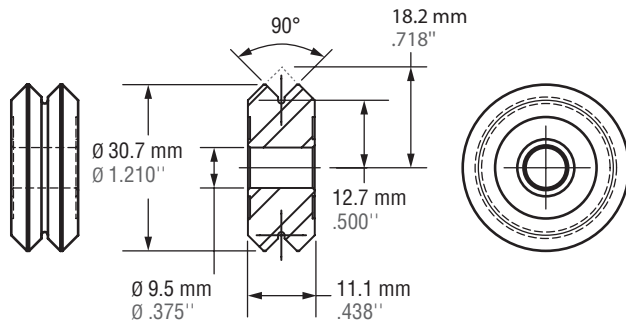

[Download CAD](#)



WHEEL BUSHINGS

| INCH SERIES | |
|---------------|-------------------------------------|
| VB2 | Concentric Fixed Bushing |
| VBA2 | Eccentric Adjustable Bushing |
| METRIC SERIES | |
| MVB2 | Concentric Metric Fixed Bushing |
| MVBA2 | Eccentric Metric Adjustable Bushing |

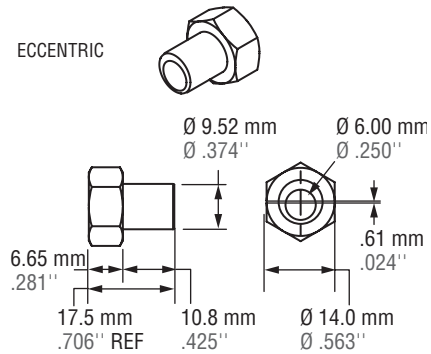
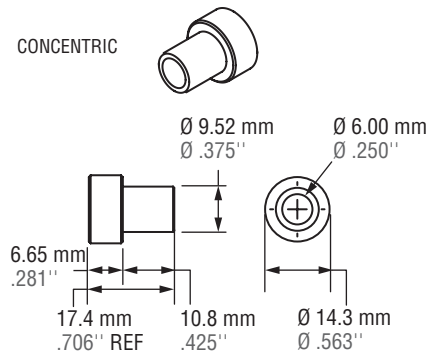

V-GUIDE RAIL

| CARBON STEEL | | STAINLESS STEEL | |
|-----------------|--|------------------|---|
| VR2-xxx | undrilled rail max. length 21' (6400 mm) | VRS2-xxx | undrilled rail, max. length 21' (6400 mm) |
| VRD2-xxx | drilled rail | VRSD2-xxx | drilled rail |

Note: Non-heat treated rails available in all sizes, contact factory.

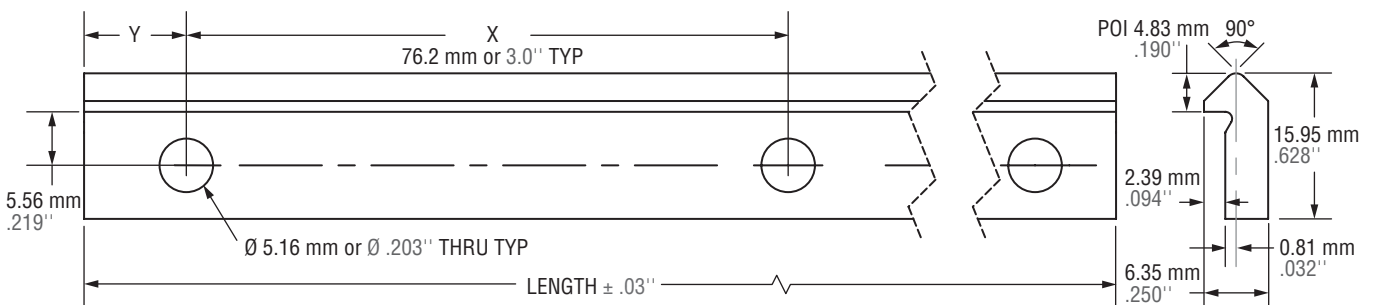

Specify Y dimension (hole to end) at time of order.



V-Guide Size 3

45 mm (1-3/4")

Radial loads to 1386 lbs. (6166 N) per wheel
 Axial loads to 326 lbs. (1448 N) per wheel
 Wheel weight: 4.6 oz. (131 g)

V-GUIDE WHEELS

| | |
|--------------|--------------------------|
| VW3 | Shielded Bearing |
| VWS3 | Sealed Bearing |
| VWSS3 | Sealed Stainless Bearing |

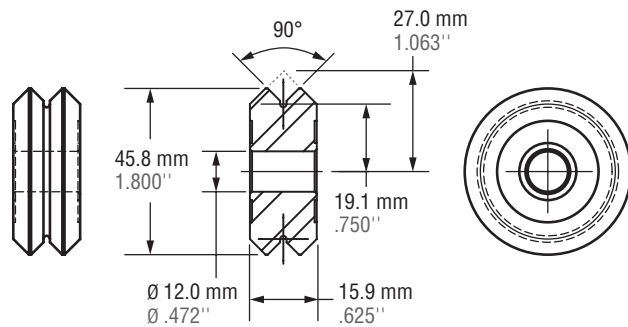

Download CAD



WHEEL BUSHINGS

| INCH SERIES | |
|---------------|-------------------------------------|
| VB3 | Concentric Fixed Bushing |
| VBA3 | Eccentric Adjustable Bushing |
| METRIC SERIES | |
| MVB3 | Concentric Metric Fixed Bushing |
| MVBA3 | Eccentric Metric Adjustable Bushing |

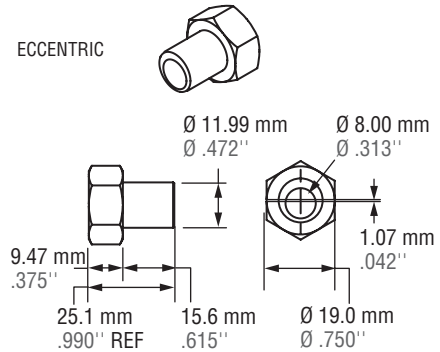
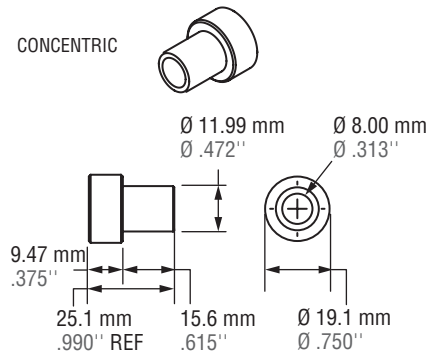

V-GUIDE RAIL

| CARBON STEEL | | STAINLESS STEEL | |
|-----------------|--|------------------|---|
| VR3-xxx | undrilled rail max. length 21' (6400 mm) | VRS3-xxx | undrilled rail, max. length 21' (6400 mm) |
| VRD3-xxx | drilled rail | VRSD3-xxx | drilled rail |

Note: Non-heat treated rails available in all sizes, contact factory.

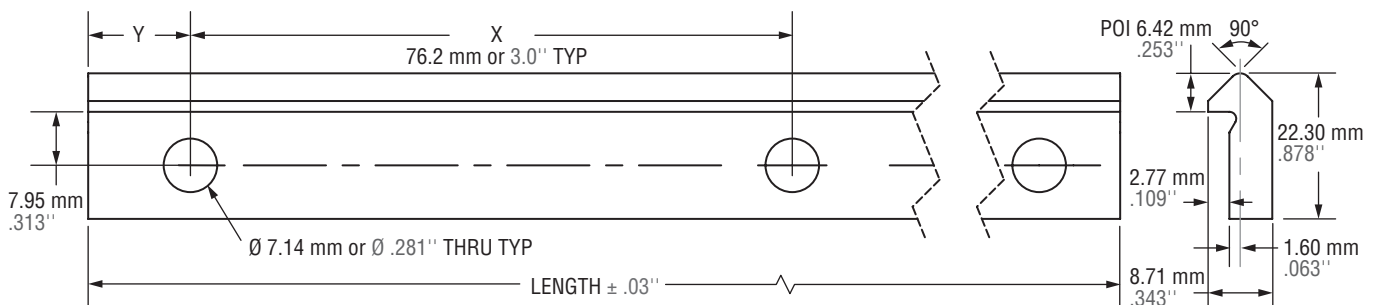

Specify Y dimension (hole to end) at time of order.

REDI-RAIL
COMMERCIAL RAIL
HARDENED CROWN ROLLER
V-GUIDE
HEVI-RAIL



60 mm (2-1/4")

Size 4 V-Guide

Radial loads to 2246 lbs. (9991 N) per wheel
 Axial loads to 520 lbs. (2313 N) per wheel
 Wheel weight: 10 oz. (281 g)

V-GUIDE WHEELS

| | |
|--------------|--------------------------|
| VW4 | Shielded Bearing |
| VWS4 | Sealed Bearing |
| VWSS4 | Sealed Stainless Bearing |

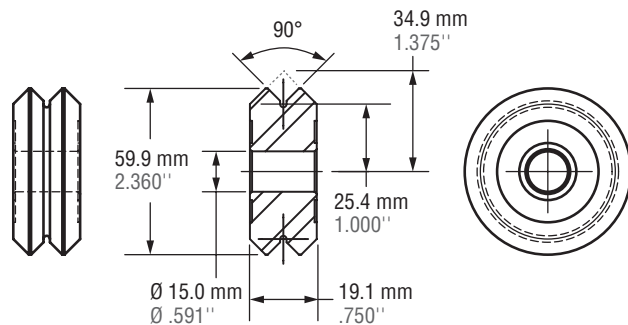

[Download CAD](#)



WHEEL BUSHINGS

| INCH SERIES | |
|---------------|-------------------------------------|
| VB4 | Concentric Fixed Bushing |
| VBA4 | Eccentric Adjustable Bushing |
| METRIC SERIES | |
| MVB4 | Concentric Metric Fixed Bushing |
| MVBA4 | Eccentric Metric Adjustable Bushing |

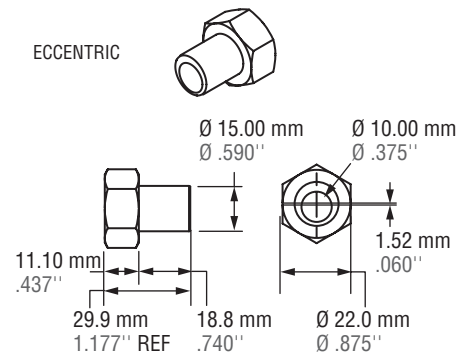
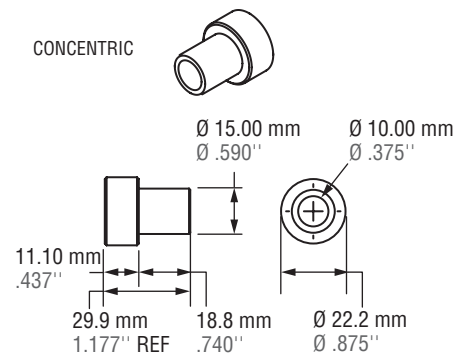

V-GUIDE RAIL

| CARBON STEEL | | STAINLESS STEEL | |
|-----------------|--|------------------|---|
| VR4-xxx | undrilled rail max. length 21' (6400 mm) | VRS4-xxx | undrilled rail, max. length 21' (6400 mm) |
| VRD4-xxx | drilled rail | VRSD4-xxx | drilled rail |

Note: Non-heat treated rails available in all sizes, contact factory.

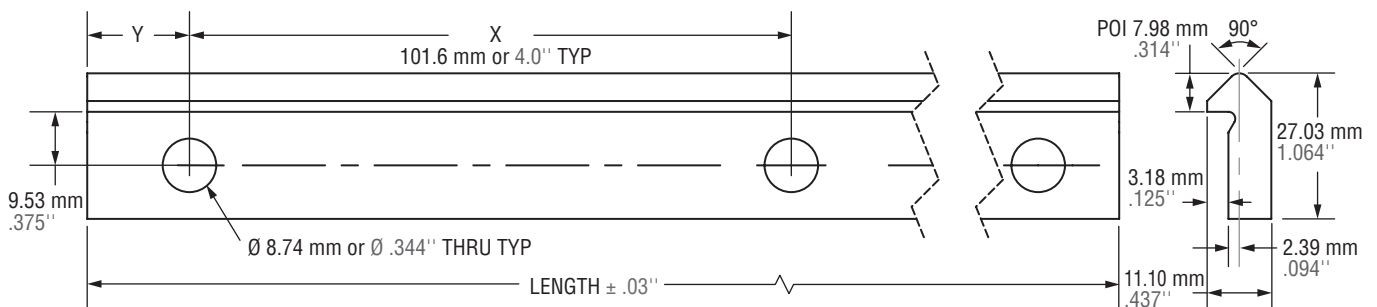

Specify Y dimension (hole to end) at time of order.



Hevi-Rail®

| COMBINED HEVI-RAIL BEARING | | RAIL | | FLANGE PLATE | CLAMP FLANGE | BEARING WITH WELDED FLANGE PLATE | | SYSTEM MAX STATIC LOAD* kN | | GENERAL DIMENSIONS** MM | | | | |
|----------------------------|------------|-----------|-----------|--------------|--------------|----------------------------------|----------------|----------------------------|-------|-------------------------|----|------|-------|------|
| FIXED | ADJUSTABLE | U-CHANNEL | I-CHANNEL | | | FIXED | ADJUSTABLE | RADIAL | AXIAL | A | B | C | D | E |
| HVB-053 | – | HVR-S | – | HVPS-1 | – | HVB-053/HVPS | – | 5.23 | 1.68 | 52.5 | 30 | 33 | 65 | 30 |
| HVB-054 | HVBEA-454 | HVR-0 | – | HVP0-1 | HVC-0 | HVB-054/HVP0 | HVBEA-454/HVP0 | 10.3 | 3.2 | 62 | 30 | 37.5 | 86.5 | 36 |
| HVB-055 | HVBEA-455 | HVR-1 | HVRI-07 | HVP1-1 | HVC-1 | HVB-055/HVP1 | HVBEA-455/HVP1 | 12.4 | 3.87 | 70.1 | 35 | 44 | 103.2 | 40 |
| HVB-056 | HVBEA-456 | HVR-2 | – | HVP2-1 | HVC-2 | HVB-056/HVP2 | HVBEA-456/HVP2 | 12.9 | 4.0 | 77.7 | 40 | 48 | 121.3 | 41 |
| HVB-057 | HVBEA-457 | – | HVRI-08 | HVP2-1 | – | HVB-057/HVP2 | HVBEA-457/HVP2 | 12.9 | 4.0 | 77.7 | 40 | 40.7 | 113.9 | 66 |
| HVB-058 | HVBEA-458 | HVR-3 | HVRI-09 | HVP3-1 | HVC-3 | HVB-058/HVP3 | HVBEA-458/HVP3 | 22.4 | 7 | 88.4 | 45 | 57 | 135.4 | 53 |
| HVB-059 | HVBEA-459 | – | HVRI-10 | – | – | – | – | 22 | 7 | 101.2 | 50 | 46 | 140.3 | 69.9 |
| HVB-060 | HVBEA-460 | – | HVRI-11 | – | – | – | – | 23.8 | 7.44 | 107.7 | 55 | 53 | 152.4 | 83 |
| HVB-061 | HVBEA-461 | HVR-4 | – | HVP4-1 | HVC-4 | HVB-061/HVP4 | HVBEA-461/HVP4 | 23.8 | 7.44 | 107.7 | 60 | 69 | 157.2 | 61.2 |
| HVB-062 | HVBEA-462 | HVR-5 | – | HVP4-1 | – | HVB-062/HVP4 | HVBEA-462/HVP4 | 33.9 | 10.6 | 123 | 60 | 72.3 | 175 | 66.2 |
| HVB-063 | HVBEA-463 | HVR-6 | – | HVP6-1 | – | HVB-063/HVP6 | HVBEA-463/HVP6 | 59.2 | 18.5 | 149 | 60 | 78.5 | 201.5 | 71.2 |

*System max static loads are achievable when used with shown rails. ** Detailed dimensions can be found on each product page.

FEATURES & BENEFITS

The economical Hevi-Rail® guide systems offer a lifetime of durability under continuous use. The easily interchangeable bearing components provide even dispersion of forces in the rails for longer system life and stability.

LINEAR BEARINGS

- Outer ring made of case-hardened steel
- Handles very high axial and radial loads
- Easily interchangeable components for less down-time
- Fixed and adjustable combined bearings available

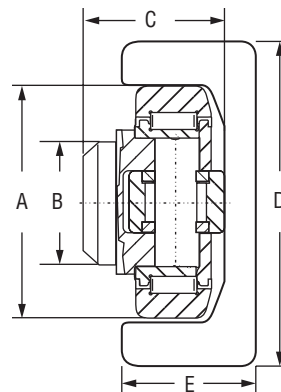

RAILS

- Standard length up to 6 meters
- Sand blasted or lightly oiled options available
- U-channel or I-channel available

CLAMP FLANGES

- Eliminates need for welding and straightening
- Easily adjustable parallelism

FLANGE PLATES

- Simple mounting for bearings
- Can be ordered pre-welded to bearing
Ordering example: HVB-054/HVPO-1

Sample Hevi-Rail Configurations

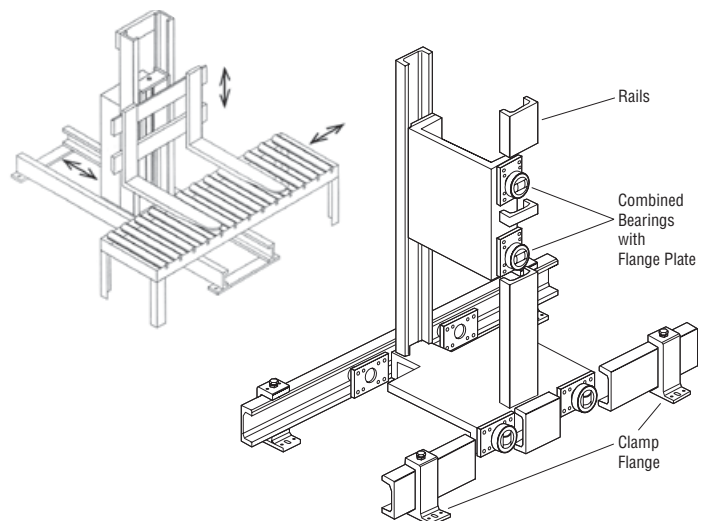



0.58 US Ton-Force

HVB-053 Hevi-Rail®



AXIAL BEARING – FIXED HVB-053

Weight = 0.36 Kg

Maximum Bearing Loads:

Radial: Dynamic = 24 kN; Static = 32 kN

Axial: Dynamic = 7 kN; Static = 7 kN

Note: Above loads achievable when used with a hardened rail 55 RC minimum 2.54 mm deep.

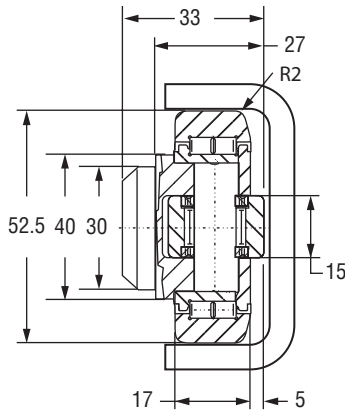

System Maximum Static Loads:

Radial: 5.23 kN / 0.58 US Ton-Force

Axial: 1.68 kN / 0.18 US Ton-Force

Note: Above loads are achievable when used with shown rails.



AXIAL BEARING – FIXED

HVB-053/HVPS

WITH WELDED FLANGE PLATE

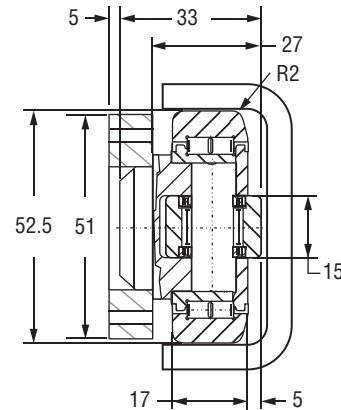

FLANGE PLATE HVPS-1

For ordering separate flange plate only

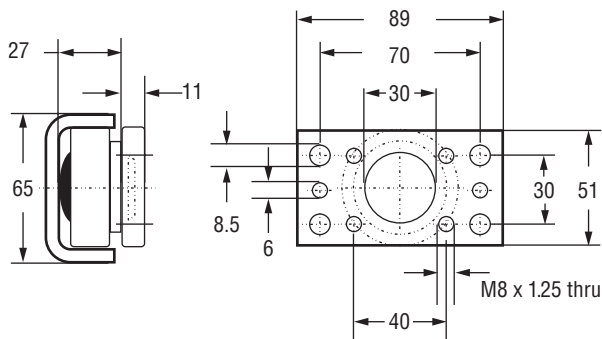

RAIL – U CHANNEL HVR-S

Weight = 5.3 Kg/m

Moment of Inertia: $I_x = 5.2 \text{ cm}^4$; $I_y = 38.8 \text{ cm}^4$

Moment of Resistance: $W_x = 2.50 \text{ cm}^3$; $W_y = 11.90 \text{ cm}^3$

Radius of Inertia: $i_x = 0.80 \text{ cm}$; $i_y = 2.40 \text{ cm}$

Distance to Center of Gravity: $e_y = 0.94 \text{ cm}$; $e_x = 32.50 \text{ cm}$

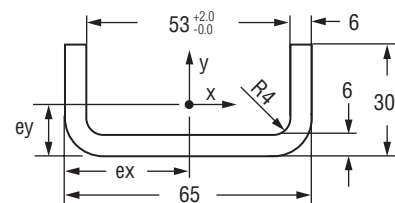

Email an Application Engineer



Link to video "Hevi-Rail Top 5 Design Tips"

ORDERING INFORMATION

| PART NUMBER | DESCRIPTION |
|--------------|--|
| HVB-053 | Fixed axial bearing |
| HVB-053/HVPS | Fixed axial bearing with welded flange plate |
| HVPS-1 | Flange plate |
| HVR-S | U-channel profile rail for -53 bearings |

REDI-RAIL

COMMERCIAL RAIL

HARDENED CROWN ROLLER

V-GUIDE

HEVI-RAIL



Hevi-Rail® HVB-054

1.15 US Ton-Force



AXIAL BEARING – FIXED HVB-054

Weight = 0.53 Kg

Maximum Bearing Loads:

Radial: Dynamic = 31 kN; Static = 35.5 kN

Axial: Dynamic = 11 kN; Static = 11 kN

Note: Above loads achievable when used with a hardened rail 55 RC minimum 2.54 mm deep.

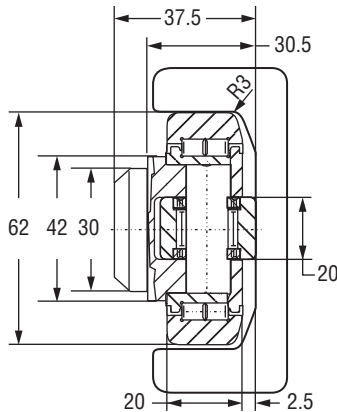

System Maximum Static Loads:

Radial: 10.3 kN / 1.15 US Ton-Force

Axial: 3.2 kN / 0.35 US Ton-Force

Note: Above loads are achievable when used with shown rails.



AXIAL BEARING – FIXED

HVB-054/HVPO

WITH WELDED FLANGE PLATE

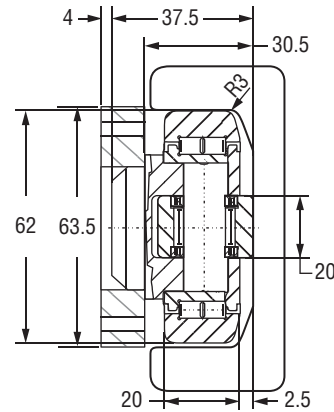

ECCENTRIC ADJUSTABLE HVBEA-454

Weight = 0.53 Kg

Maximum Bearing Loads:

Radial: Dynamic = 31 kN; Static = 35.5 kN

Axial: Dynamic = 11 kN; Static = 11 kN

Note: Above loads achievable when used with a hardened rail 55 RC minimum 2.54 mm deep.

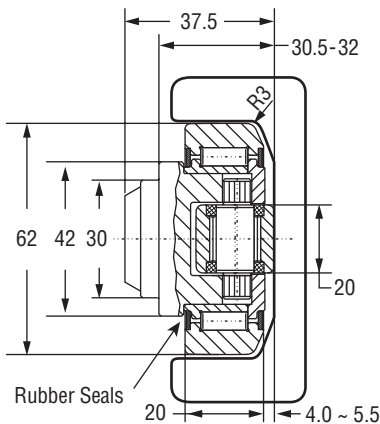

ECCENTRIC ADJUSTABLE

HVBEA-454/HVPO

WITH WELDED FLANGE PLATE

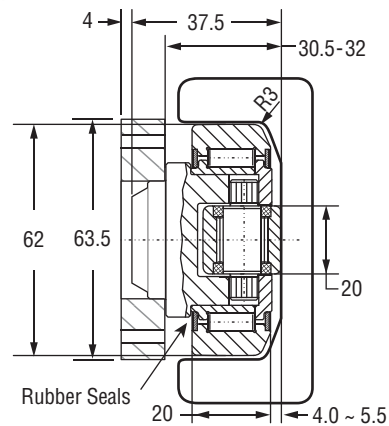

Download CAD



1.15 US Ton-Force

HVB-054 Hevi-Rail®

RAIL – U CHANNEL HVR-0

Weight = 10.5 Kg/m
Moment of Inertia: $I_x = 15.35 \text{ cm}^4$; $I_y = 137.05 \text{ cm}^4$
Moment of Resistance: $W_{x_{min}} = 6.64 \text{ cm}^3$;
 $W_{x_{max}} = 11.93 \text{ cm}^3$; $W_y = 31.69 \text{ cm}^3$
Radius of Inertia: $i_x = 1.07 \text{ cm}$; $i_y = 3.20 \text{ cm}$
Distance to Center of Gravity: $e_y = 1.29 \text{ cm}$; $e_x = 4.33 \text{ cm}$

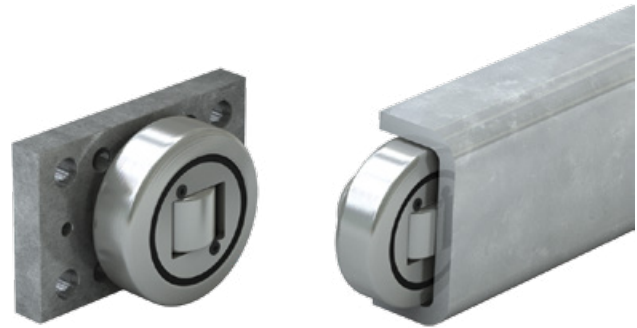
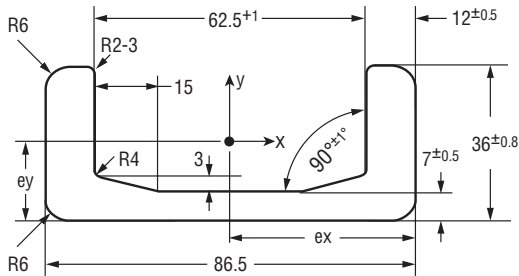

● **HEVI-RAIL BEARINGS**
 Can be ordered with pre-welded flange plate

FLANGE PLATE HVPO-1

For ordering separate flange plate only

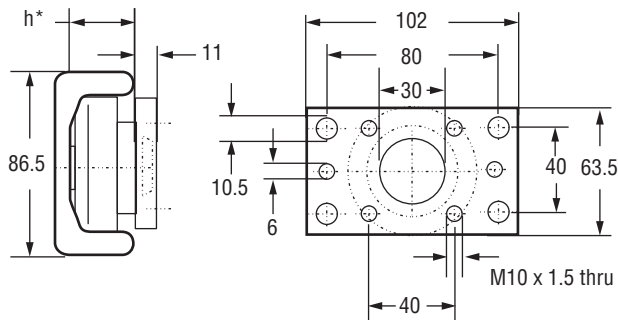

* Note: "h" refers to the depth of the axial bearing. This dimension depends on the choice of fixed axial bearing (HVB-054) or eccentric adjustable bearing (HVBEA-454).

CLAMP FLANGE HVC-0

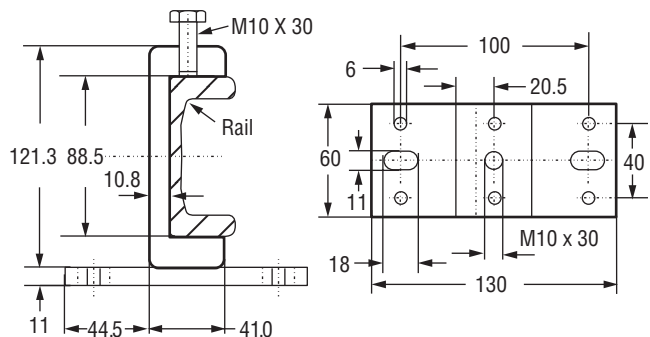

ORDERING INFORMATION

| PART NUMBER | DESCRIPTION |
|----------------|---|
| HVB-054 | Fixed axial bearing |
| HVB-054/HVPO | Fixed axial bearing with welded flange plate |
| HVBEA-454 | Eccentric adjustable axial bearing |
| HVBEA-454/HVPO | Eccentric adjustable axial bearing with welded flange plate |
| HVPO-1 | Flange plate |
| HVR-0 | U-channel rail for -54 bearings |
| HVC-0 | Clamp flange |



Hevi-Rail® HVB-055

1.39 US Ton-Force



AXIAL BEARING – FIXED HVB-055

Weight = 0.80 Kg

Maximum Bearing Loads:

Radial: Dynamic = 45.5 kN; Static = 51 kN

Axial: Dynamic = 13 kN; Static = 14 kN

Note: Above loads achievable when used with a hardened rail 55 RC minimum 2.54 mm deep.

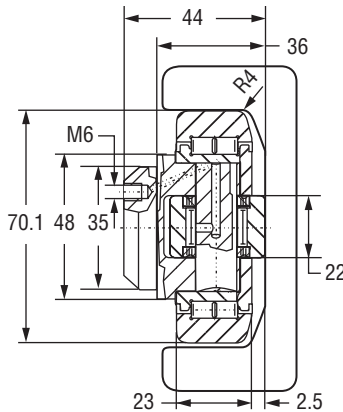

System Maximum Static Loads:

Radial: 12.4 kN / 1.39 US Ton-Force

Axial: 3.87 kN / 0.43 US Ton-Force

Note: Above loads are achievable when used with shown rails.



AXIAL BEARING – FIXED

HVB-055/HVP1

WITH WELDED FLANGE PLATE

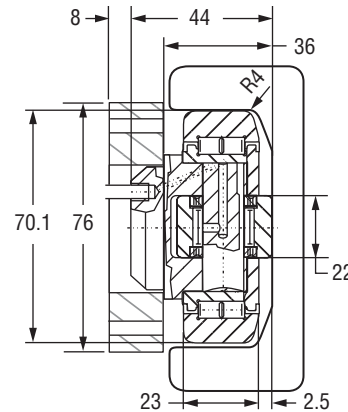

ECCENTRIC ADJUSTABLE HVBEA-455

Weight = 0.80 Kg

Maximum Bearing Loads:

Radial: Dynamic = 45.5 kN; Static = 51 kN

Axial: Dynamic = 13 kN; Static = 14 kN

Note: Above loads achievable when used with a hardened rail 55 RC minimum 2.54 mm deep.

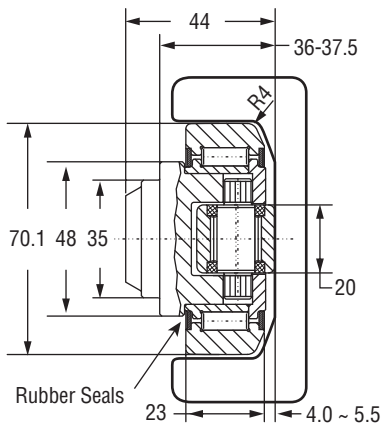

ECCENTRIC ADJUSTABLE

HVBEA-455/HVP1

WITH WELDED FLANGE PLATE

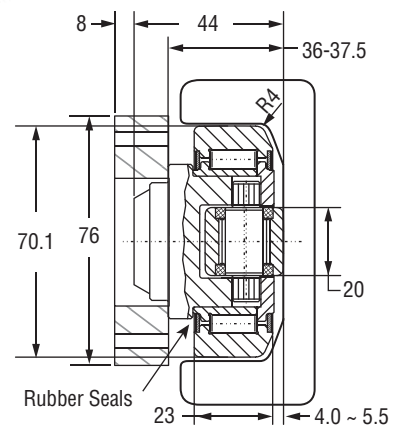

Download CAD



1.39 US Ton-Force

HVB-055 Hevi-Rail®

RAIL – U CHANNEL HVR-1

Weight = 14.8 Kg/m
Moment of Inertia: $I_x = 27.29 \text{ cm}^4$; $I_y = 273.50 \text{ cm}^4$
Moment of Resistance: $W_{x_{\min}} = 10.91 \text{ cm}^3$;
 $W_{x_{\max}} = 18.20 \text{ cm}^3$; $W_y = 53.00 \text{ cm}^3$
Radius of Inertia: $i_x = 1.20 \text{ cm}$; $i_y = 3.81 \text{ cm}$
Distance to Center of Gravity: $e_y = 1.50 \text{ cm}$; $e_x = 5.16 \text{ cm}$

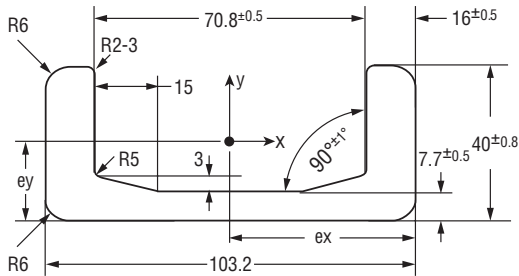

RAIL – I CHANNEL HVRI-07

Weight = 19.4 Kg/m
Moment of Inertia: $I_x = 344.29 \text{ cm}^4$; $I_y = 57.63 \text{ cm}^4$
Moment of Resistance: $W_x = 70.26 \text{ cm}^3$; $W_y = 17.73 \text{ cm}^3$
Radius of Inertia: $i_x = 3.73 \text{ cm}$; $i_y = 1.52 \text{ cm}$
Distance to Center of Gravity: $e_y = 4.90 \text{ cm}$; $e_x = 3.25 \text{ cm}$

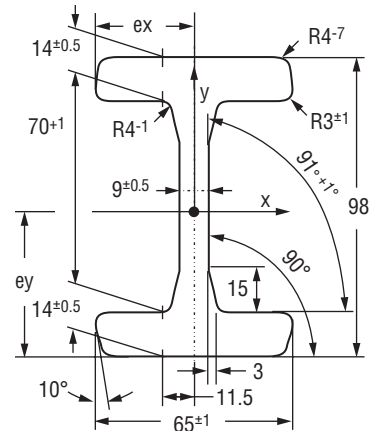

FLANGE PLATE HVP1-1

For ordering separate flange plate only

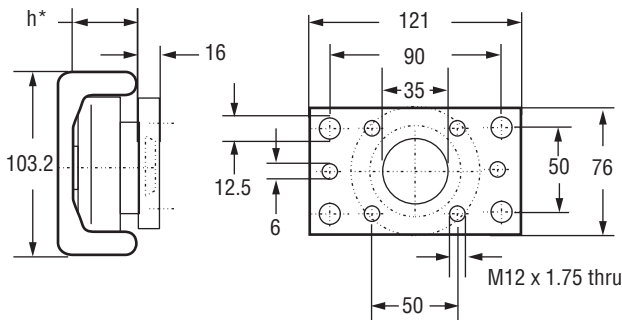

* Note: "h" refers to the depth of the axial bearing. This dimension depends on the choice of fixed axial bearing (HVB-055) or eccentric adjustable bearing (HVBEA-455).

CLAMP FLANGE HVC-1

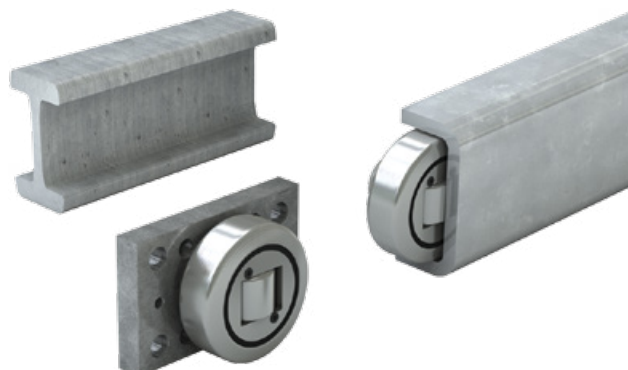
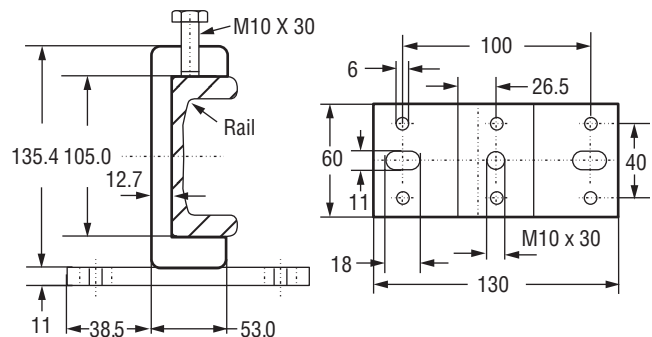

ORDERING INFORMATION

| PART NUMBER | DESCRIPTION |
|----------------|---|
| HVB-055 | Fixed axial bearing |
| HVB-055/HVP1 | Fixed axial bearing with welded flange plate |
| HVBEA-455 | Eccentric adjustable axial bearing |
| HVBEA-455/HVP1 | Eccentric adjustable axial bearing with welded flange plate |
| HVP1-1 | Flange plate |
| HVR-1 | U-channel rail for -55 bearings |
| HVRI-07 | I-channel rail for -55 bearings |
| HVC-1 | Clamp flange |



Hevi-Rail® HVB-056

1.45 US Ton-Force



AXIAL BEARING – FIXED HVB-056

Weight = 1.00 Kg

Maximum Bearing Loads:

Radial: Dynamic = 48 kN; Static = 56.8 kN

Axial: Dynamic = 18 kN; Static = 18 kN

Note: Above loads achievable when used with a hardened rail 55 RC minimum 2.54 mm deep.

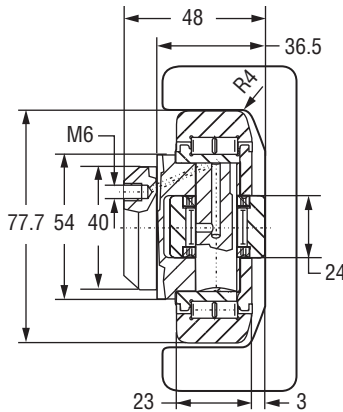

System Maximum Static Loads:

Radial: 12.9 kN / 1.45 US Ton-Force

Axial: 4.0 kN / 0.44 US Ton-Force

Note: Above loads are achievable when used with shown rails.



AXIAL BEARING – FIXED

HVB-056/HVP2

WITH WELDED FLANGE PLATE

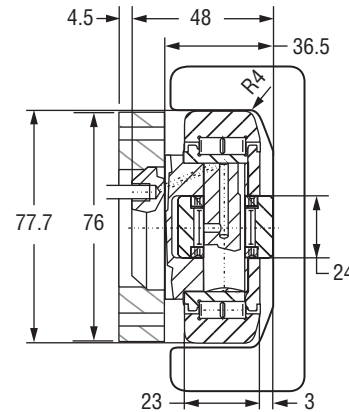

ECCENTRIC ADJUSTABLE HVBEA-456

Weight = 1.00 Kg

Maximum Bearing Loads:

Radial: Dynamic = 48 kN; Static = 56.8 kN

Axial: Dynamic = 18 kN; Static = 18 kN

Note: Above loads achievable when used with a hardened rail 55 RC minimum 2.54 mm deep.

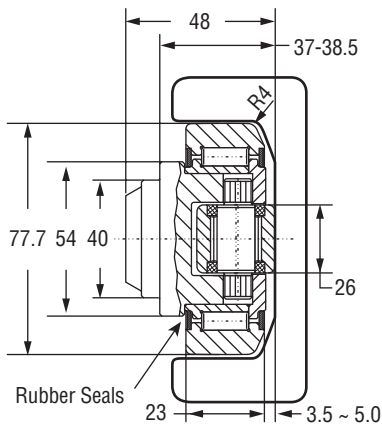

ECCENTRIC ADJUSTABLE

HVBEA-456/HVP2

WITH WELDED FLANGE PLATE

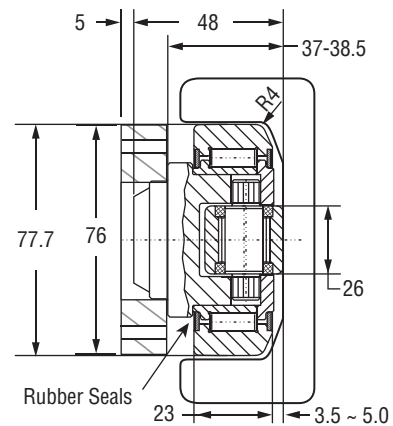

Download CAD

REDI-RAIL
COMMERCIAL RAIL
HARDENED CROWN ROLLER
V-GUIDE
HEVI-RAIL



1.45 US Ton-Force

HVB-056 Hevi-Rail®

RAIL – U CHANNEL HVR-2

Weight = 20.9 Kg/m
Moment of Inertia: $I_x = 37.92 \text{ cm}^4$; $I_y = 493.58 \text{ cm}^4$
Moment of Resistance: $W_{x_{\min}} = 14.83 \text{ cm}^3$;
 $W_{x_{\max}} = 24.58 \text{ cm}^3$; $W_y = 81.38 \text{ cm}^3$
Radius of Inertia: $i_x = 1.19 \text{ cm}$; $i_y = 4.30 \text{ cm}$
Distance to Center of Gravity: $e_y = 1.54 \text{ cm}$; $e_x = 6.07 \text{ cm}$

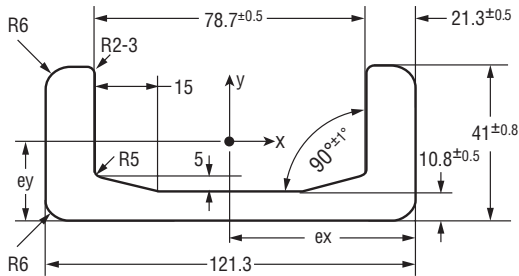

● **HEVI-RAIL BEARINGS**
 Can be ordered with pre-welded flange plate

FLANGE PLATE HVP2-1

For ordering separate flange plate only

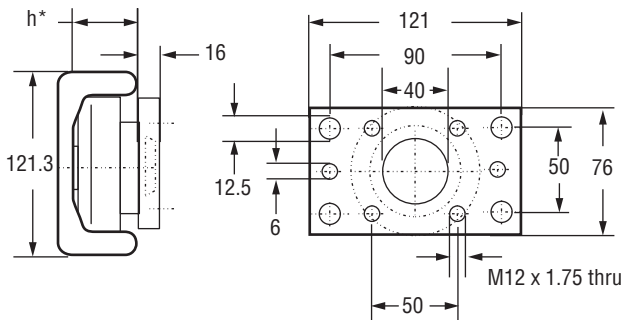

* Note: "h" refers to the depth of the axial bearing. This dimension depends on the choice of fixed axial bearing (HVB-056) or eccentric adjustable bearing (HVBEA-456).

CLAMP FLANGE HVC-2

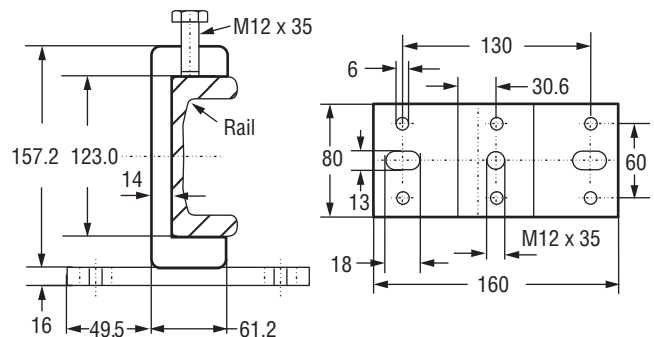

ORDERING INFORMATION

| PART NUMBER | DESCRIPTION |
|----------------|---|
| HVB-056 | Fixed axial bearing |
| HVB-056/HVP2 | Fixed axial bearing with welded flange plate |
| HVBEA-456 | Eccentric adjustable axial bearing |
| HVBEA-456/HVP2 | Eccentric adjustable axial bearing with welded flange plate |
| HVP2-1 | Flange plate |
| HVR-2 | U-channel rail for -56 bearings |
| HVC-2 | Clamp flange |



Hevi-Rail® HVB-057

1.45 US Ton-Force



AXIAL BEARING – FIXED HVB-057

Weight = 0.90 Kg

Maximum Bearing Loads:

Radial: Dynamic = 48 kN; Static = 56.8 kN

Axial: Dynamic = 18 kN; Static = 18 kN

Note: Above loads achievable when used with a hardened rail 55 RC minimum 2.54 mm deep.

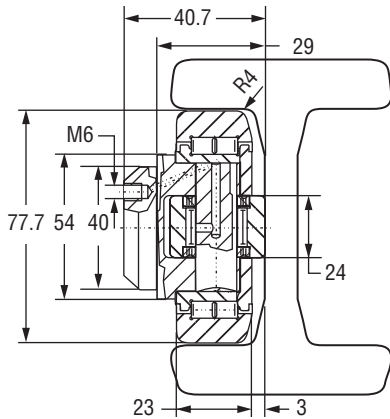

System Maximum Static Loads:

Radial: 12.9 kN / 1.45 US Ton-Force

Axial: 4.0 kN / 0.44 US Ton-Force

Note: Above loads are achievable when used with shown rails.



AXIAL BEARING – FIXED

HVB-057/HVP2

WITH WELDED FLANGE PLATE

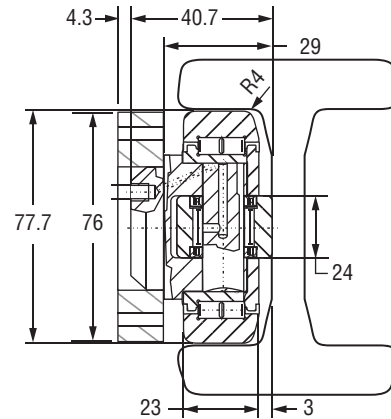

ECCENTRIC ADJUSTABLE HVBEA-457

Weight = 0.87 Kg

Maximum Bearing Loads:

Radial: Dynamic = 48 kN; Static = 56.8 kN

Axial: Dynamic = 18 kN; Static = 18 kN

Note: Above loads achievable when used with a hardened rail 55 RC minimum 2.54 mm deep.

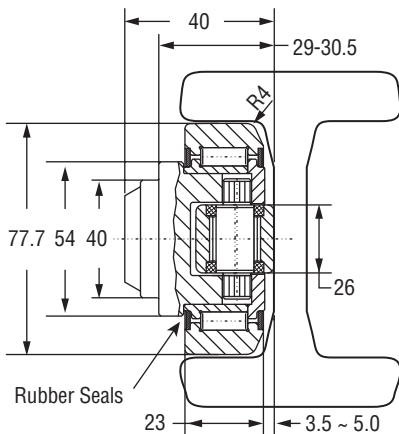

ECCENTRIC ADJUSTABLE

HVBEA-457/HVP2

WITH WELDED FLANGE PLATE

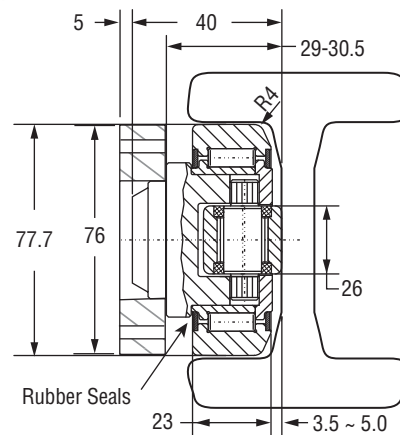

Download CAD

REDI-RAIL

COMMERCIAL RAIL

HARDENED CROWN ROLLER

V-GUIDE

HEVI-RAIL



1.0 US Ton-Force

HVB-057 Hevi-Rail®

RAIL – I CHANNEL HVRI-08

Weight = 25.3 Kg/m
Moment of Inertia: $I_x = 597.54 \text{ cm}^4$; $I_y = 76.79 \text{ cm}^4$
Moment of Resistance: $W_x = 104.92 \text{ cm}^3$; $W_y = 23.27 \text{ cm}^3$
Radius of Inertia: $i_x = 4.24 \text{ cm}$; $i_y = 1.54 \text{ cm}$
Distance to Center of Gravity: $e_y = 5.70 \text{ cm}$; $e_x = 3.30 \text{ cm}$

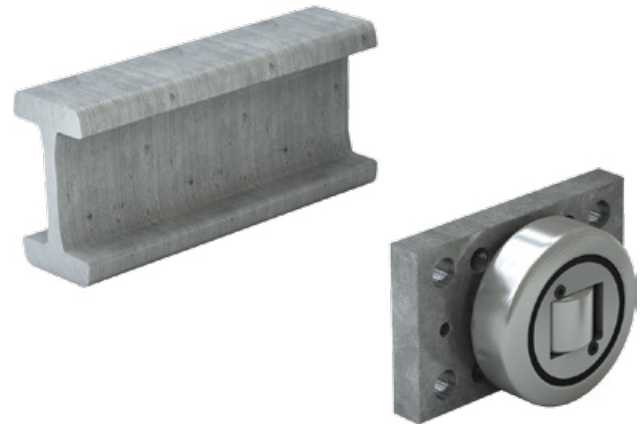
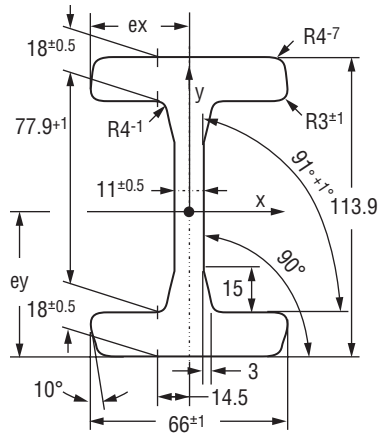

HEVI-RAIL BEARINGS
 Can be ordered with pre-welded flange plate

FLANGE PLATE HVP2-1

For ordering separate flange plate only

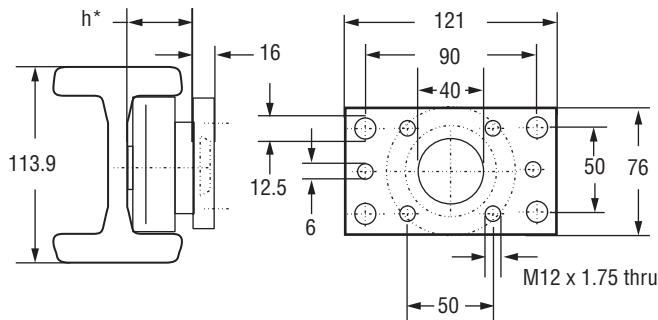

* Note: "h" refers to the depth of the axial bearing. This dimension depends on the choice of fixed axial bearing (HVB-057) or eccentric adjustable bearing (HVBEA-457).

REDI-RAIL

COMMERCIAL RAIL

HARDENED CROWN ROLLER

V-GUIDE

HEVI-RAIL

ORDERING INFORMATION

| PART NUMBER | DESCRIPTION |
|----------------|---|
| HVB-057 | Fixed axial bearing |
| HVB-057/HVP2 | Fixed axial bearing with welded flange plate |
| HVBEA-457 | Eccentric adjustable axial bearing |
| HVBEA-457/HVP2 | Eccentric adjustable axial bearing with welded flange plate |
| HVP2-1 | Flange plate |
| HVRI-08 | I-channel rail for -57 bearings |



Hevi-Rail® HVB-058

2.51 US Ton-Force



AXIAL BEARING – FIXED HVB-058

Weight = 1.62 Kg

Maximum Bearing Loads:

Radial: Dynamic = 68 kN; Static = 72 kN

Axial: Dynamic = 23 kN; Static = 23 kN

Note: Above loads achievable when used with a hardened rail 55 RC minimum 2.54 mm deep.

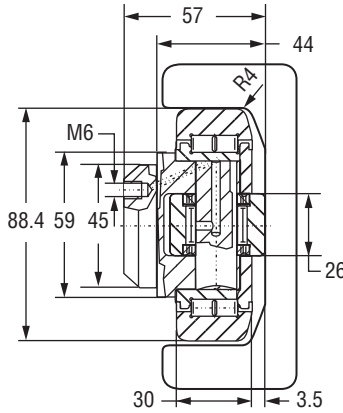

System Maximum Static Loads:

Radial: 22.4 kN / 2.51 US Ton-Force

Axial: 7.0 kN / 0.78 US Ton-Force

Note: Above loads are achievable when used with shown rails.



AXIAL BEARING – FIXED

HVB-058/HVP3

WITH WELDED FLANGE PLATE

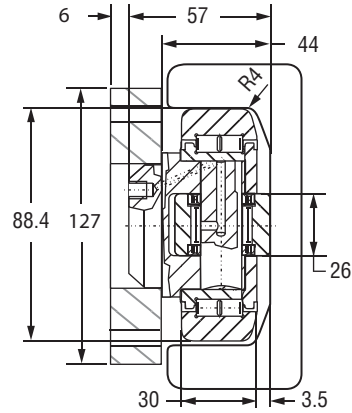

ECCENTRIC ADJUSTABLE HVBEA-458

Weight = 1.62 Kg

Maximum Bearing Loads:

Radial: Dynamic = 68 kN; Static = 72 kN

Axial: Dynamic = 23 kN; Static = 23 kN

Note: Above loads achievable when used with a hardened rail 55 RC minimum 2.54 mm deep.

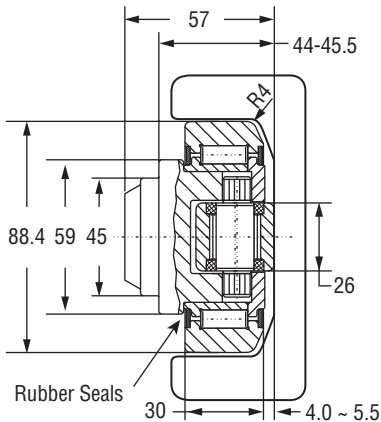

ECCENTRIC ADJUSTABLE

HVBEA-458/HVP3

WITH WELDED FLANGE PLATE

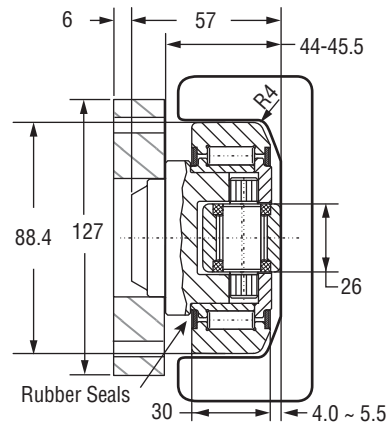

Download CAD

REDI-RAIL

COMMERCIAL RAIL

HARDENED CROWN ROLLER

V-GUIDE

HEVI-RAIL



2.51 US Ton-Force

HVB-058 Hevi-Rail®

RAIL – U CHANNEL HVR-3

Weight = 14.8 Kg/m
Moment of Inertia: $I_x = 27.29 \text{ cm}^4$; $I_y = 273.50 \text{ cm}^4$
Moment of Resistance: $W_{x_{\min}} = 10.91 \text{ cm}^3$;
 $W_{x_{\max}} = 18.20 \text{ cm}^3$; $W_y = 53.00 \text{ cm}^3$
Radius of Inertia: $i_x = 1.20 \text{ cm}$; $i_y = 3.81 \text{ cm}$
Distance to Center of Gravity: $e_y = 1.50 \text{ cm}$; $e_x = 5.16 \text{ cm}$

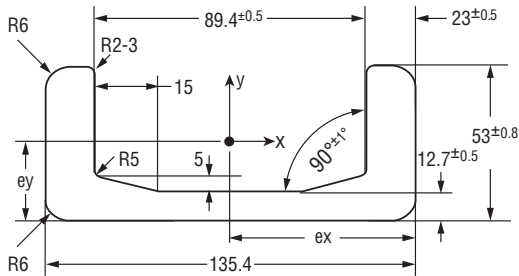

RAIL – I CHANNEL HVRI-09

Weight = 34.1 Kg/m
Moment of Inertia: $I_x = 1037.22 \text{ cm}^4$; $I_y = 161.89 \text{ cm}^4$
Moment of Resistance: $W_x = 160.07 \text{ cm}^3$; $W_y = 39.97 \text{ cm}^3$
Radius of Inertia: $i_x = 4.89 \text{ cm}$; $i_y = 1.93 \text{ cm}$
Distance to Center of Gravity: $e_y = 6.48 \text{ cm}$; $e_x = 4.05 \text{ cm}$

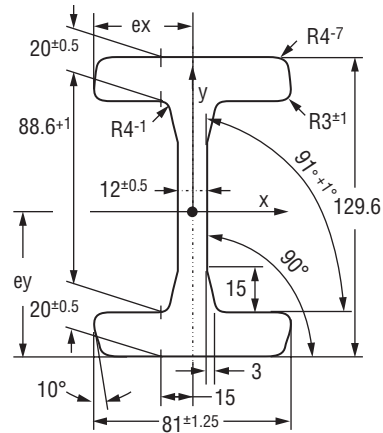

FLANGE PLATE HVP3-1

For ordering separate flange plate only

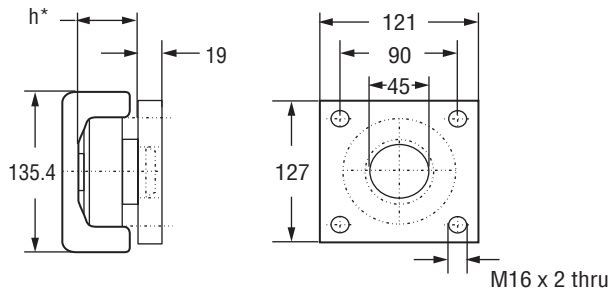

* Note: "h" refers to the depth of the axial bearing. This dimension depends on the choice of fixed axial bearing (HVB-058) or eccentric adjustable bearing (HVBEA-458).

CLAMP FLANGE HVC-3

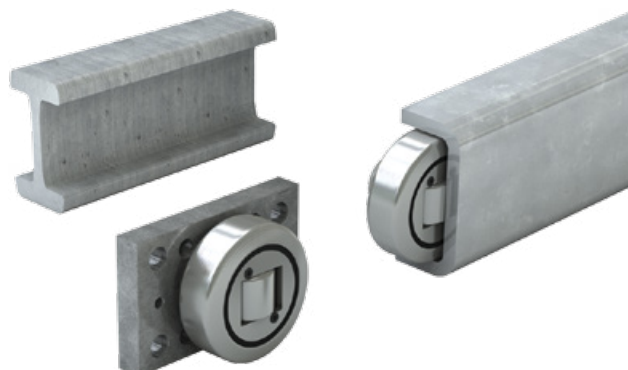
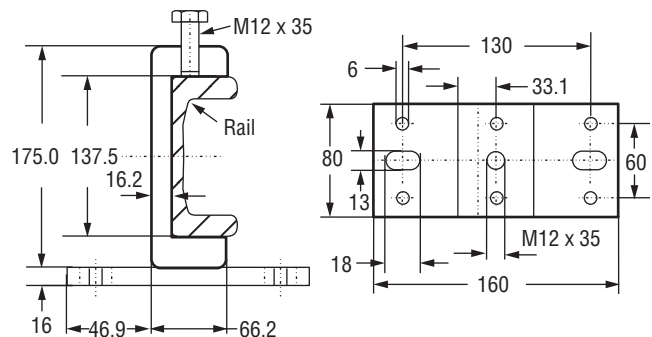

ORDERING INFORMATION

| PART NUMBER | DESCRIPTION |
|----------------|---|
| HVB-058 | Fixed axial bearing |
| HVB-058/HVP3 | Fixed axial bearing with welded flange plate |
| HVBEA-458 | Eccentric adjustable axial bearing |
| HVBEA-458/HVP3 | Eccentric adjustable axial bearing with welded flange plate |
| HVP3-1 | Flange plate |
| HVR-3 | U-channel rail for -58 bearings |
| HVRI-09 | I-channel rail for -58 bearings |
| HVC-3 | Clamp flange |



Hevi-Rail® HVB-059

2.47 US Ton-Force



AXIAL BEARING – FIXED HVB-059

Weight = 1.80 Kg

Maximum Bearing Loads:

Radial: Dynamic = 73 kN; Static = 82 kN

Axial: Dynamic = 25 kN; Static = 27 kN

Note: Above loads achievable when used with a hardened rail 55 RC minimum 2.54 mm deep.

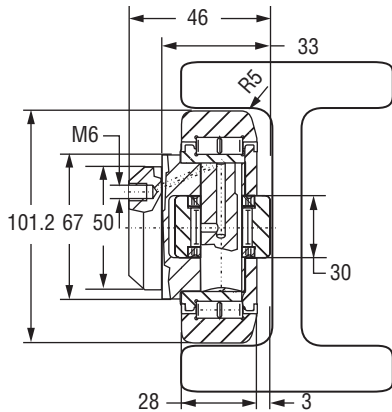

System Maximum Static Loads:

Radial: 22 kN / 2.47 US Ton-Force

Axial: 7.0 kN / 0.78 US Ton-Force

Note: Above loads are achievable when used with shown rails.

RAIL – I CHANNEL HVRI-10

Weight = 30.9 Kg/m

Moment of Inertia: $I_x = 1078.01 \text{ cm}^4$; $I_y = 104.38 \text{ cm}^4$

Moment of Resistance: $W_x = 154.33 \text{ cm}^3$; $W_y = 29.89 \text{ cm}^3$

Distance to Center of Gravity: $e_y = 6.99 \text{ cm}$; $e_x = 3.49 \text{ cm}$

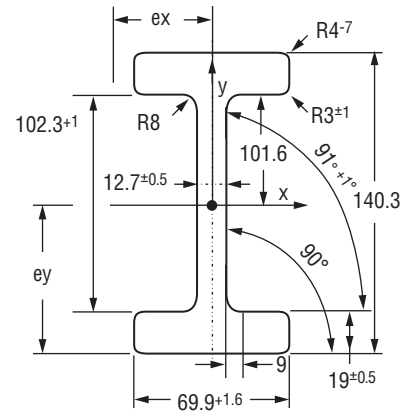

ECCENTRIC ADJUSTABLE HVBEA-459

Weight = 1.74 Kg

Maximum Bearing Loads:

Radial: Dynamic = 73 kN; Static = 82 kN

Axial: Dynamic = 25 kN; Static = 27 kN

Note: Above loads achievable when used with a hardened rail 55 RC minimum 2.54 mm deep.

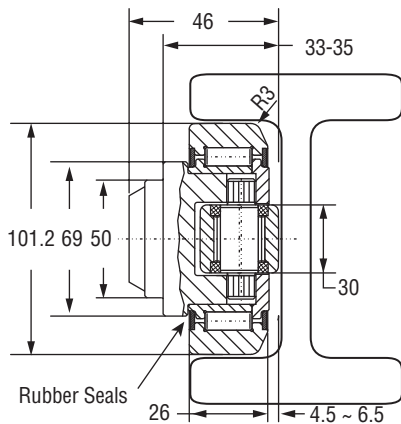

ORDERING INFORMATION

| PART NUMBER | DESCRIPTION |
|-------------|------------------------------------|
| HVB-059 | Fixed axial bearing |
| HVBEA-459 | Eccentric adjustable axial bearing |
| HVRI-10 | I-channel profile rail |



Download CAD

REDI-RAIL
COMMERCIAL RAIL
HARDENED CROWN ROLLER
V-GUIDE
HEVI-RAIL



2.67 US Ton-Force

HVB-060 Hevi-Rail®



AXIAL BEARING – FIXED HVB-060

Weight = 2.30 Kg

Maximum Bearing Loads:

Radial: Dynamic = 81 kN; Static = 95 kN

Axial: Dynamic = 31 kN; Static = 36 kN

Note: Above loads achievable when used with a hardened rail 55 RC minimum 2.54 mm deep.

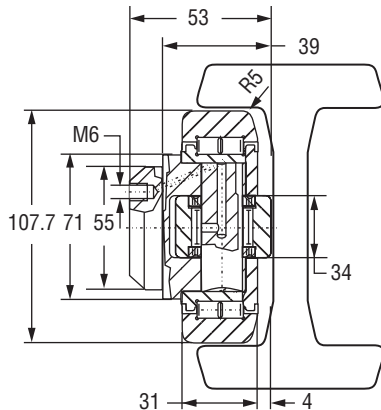

System Maximum Static Loads:

Radial: 23.8 kN / 2.67 US Ton-Force

Axial: 7.44 kN / 0.83 US Ton-Force

Note: Above loads are achievable when used with shown rails.

RAIL – I CHANNEL HVRI-11

Weight = 40.5 Kg/m

Moment of Inertia: $I_x = 1670.08 \text{ cm}^4$; $I_y = 184.52 \text{ cm}^4$

Moment of Resistance: $W_x = 219.17 \text{ cm}^3$; $W_y = 44.46 \text{ cm}^3$

Radius of Inertia: $i_x = 5.69 \text{ cm}$; $i_y = 1.91 \text{ cm}$

Distance to Center of Gravity: $e_y = 7.62 \text{ cm}$; $e_x = 4.15 \text{ cm}$

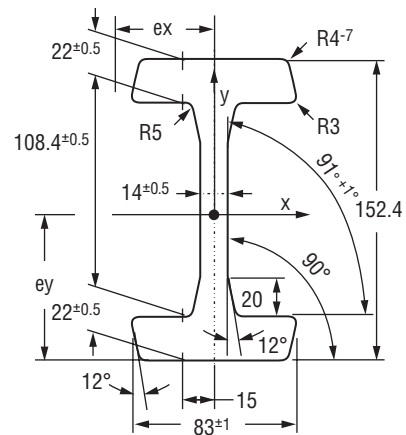

ECCENTRIC ADJUSTABLE HVBEA-460

Weight = 2.27 Kg

Maximum Bearing Loads:

Radial: Dynamic = 81 kN; Static = 95 kN

Axial: Dynamic = 31 kN; Static = 36 kN

Note: Above loads achievable when used with a hardened rail 55 RC minimum 2.54 mm deep.

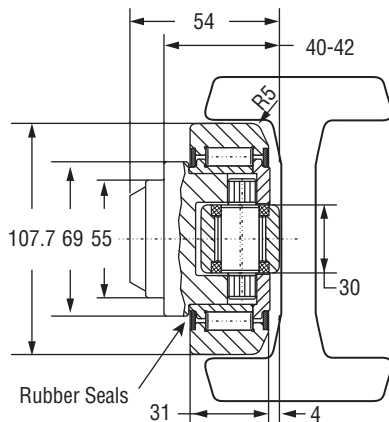

ORDERING INFORMATION

| PART NUMBER | DESCRIPTION |
|-------------|------------------------------------|
| HVB-060 | Fixed axial bearing |
| HVBEA-460 | Eccentric adjustable axial bearing |
| HVRI-11 | I-channel profile rail |



Download CAD



Hevi-Rail® HVB-061

2.67 US Ton-Force



AXIAL BEARING – FIXED HVB-061

Weight = 2.82 Kg

Maximum Bearing Loads:

Radial: Dynamic = 81 kN; Static = 95 kN

Axial: Dynamic = 31 kN; Static = 36 kN

Note: Above loads achievable when used with a hardened rail 55 RC minimum 2.54 mm deep.

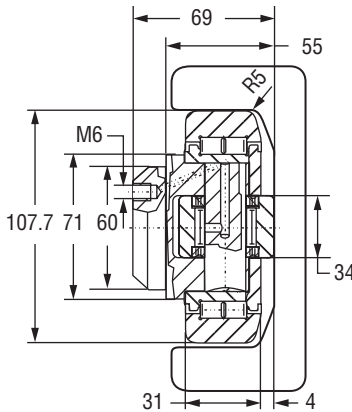

System Maximum Static Loads:

Radial: 23.8 kN / 2.67 US Ton-Force

Axial: 7.44 kN / 0.83 US Ton-Force

Note: Above loads are achievable when used with shown rails.



AXIAL BEARING – FIXED

HVB-061/HVP4

WITH WELDED FLANGE PLATE

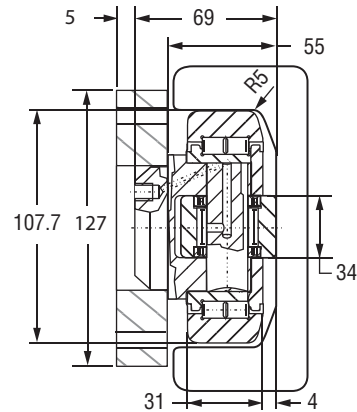

ECCENTRIC ADJUSTABLE HVBEA-461

Weight = 2.82 Kg

Maximum Bearing Loads:

Radial: Dynamic = 81 kN; Static = 95 kN

Axial: Dynamic = 31 kN; Static = 36 kN

Note: Above loads achievable when used with a hardened rail 55 RC minimum 2.54 mm deep.

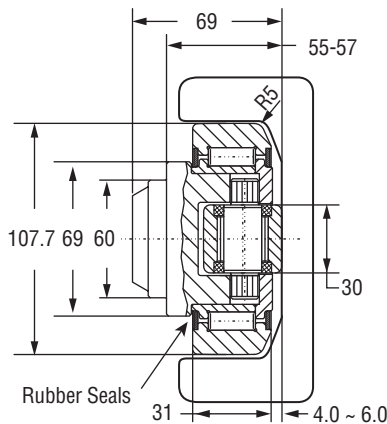

ECCENTRIC ADJUSTABLE

HVBEA-461/HVP4

WITH WELDED FLANGE PLATE

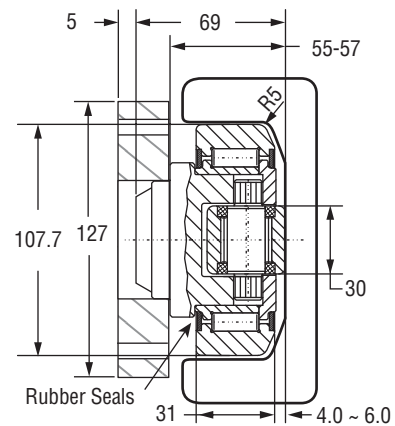

Download CAD

REDI-RAIL
COMMERCIAL RAIL
HARDENED CROWN ROLLER
V-GUIDE
HEVI-RAIL



2.67 US Ton-Force

HVB-061 Hevi-Rail®

RAIL – U CHANNEL HVR-4

Weight = 35.9 Kg/m

Moment of Inertia: $I_x = 150.98 \text{ cm}^4$; $I_y = 1494.32 \text{ cm}^4$

Moment of Resistance: $W_{x_{min}} = 39.00 \text{ cm}^3$;

$W_{x_{max}} = 67.13 \text{ cm}^3$; $W_y = 190.12 \text{ cm}^3$

Radius of Inertia: $i_x = 1.82 \text{ cm}$; $i_y = 5.72 \text{ cm}$

Distance to Center of Gravity: $e_y = 2.25 \text{ cm}$; $e_x = 7.86 \text{ cm}$

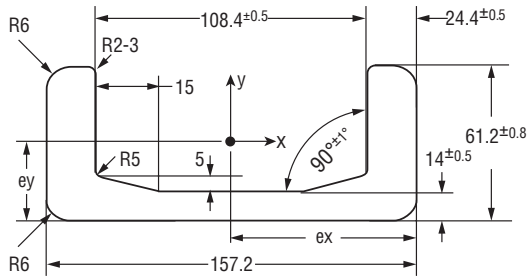

● **HEVI-RAIL BEARINGS**
Can be ordered with pre-welded flange plate

FLANGE PLATE HVP4-1

For ordering separate flange plate only

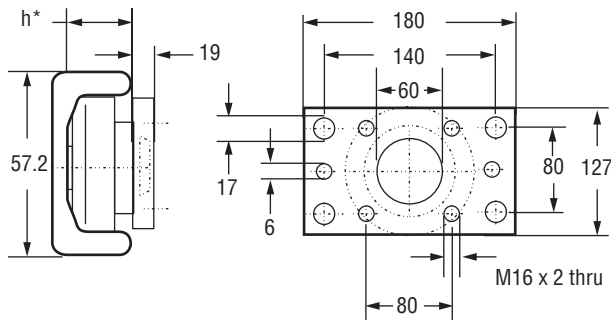

* Note: "h" refers to the depth of the axial bearing. This dimension depends on the choice of fixed axial bearing (HVB-061) or eccentric adjustable bearing (HVBEA-461).

CLAMP FLANGE HVC-4

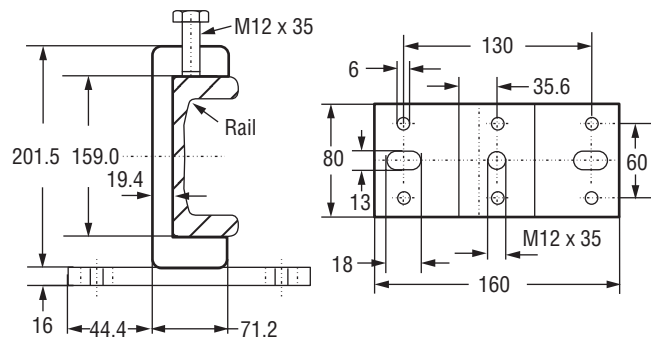

ORDERING INFORMATION

| PART NUMBER | DESCRIPTION |
|----------------|---|
| HVB-061 | Fixed axial bearing |
| HVB-061/HVP4 | Fixed axial bearing with welded flange plate |
| HVBEA-461 | Eccentric adjustable axial bearing |
| HVBEA-461/HVP4 | Eccentric adjustable axial bearing with welded flange plate |
| HVP4-1 | Flange plate |
| HVR-4 | U-channel rail for -61 bearings |
| HVC-4 | Clamp flange |



Hevi-Rail® HVB-062

3.81 US Ton-Force



AXIAL BEARING – FIXED HVB-062

Weight = 4.50 Kg

Maximum Bearing Loads:

Radial: Dynamic = 110 kN; Static = 132 kN

Axial: Dynamic = 43 kN; Static = 50 kN

Note: Above loads achievable when used with a hardened rail 55 RC minimum 2.54 mm deep.

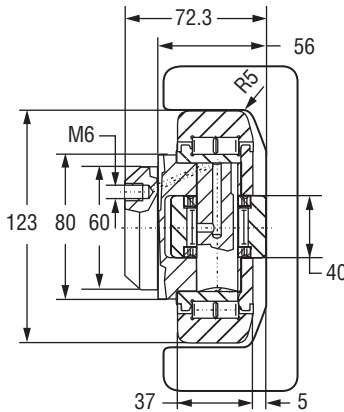

System Maximum Static Loads:

Radial: 33.9 kN / 3.81 US Ton-Force

Axial: 10.6 kN / 1.19 US Ton-Force

Note: Above loads are achievable when used with shown rails.



AXIAL BEARING – FIXED

HVB-062/HVP4

WITH WELDED FLANGE PLATE

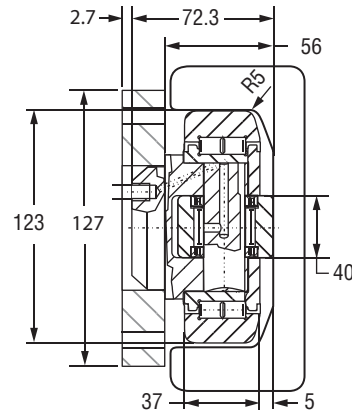

ECCENTRIC ADJUSTABLE HVBEA-462

Weight = 3.90 Kg

Maximum Bearing Loads:

Radial: Dynamic = 110 kN; Static = 132 kN

Axial: Dynamic = 43 kN; Static = 50 kN

Note: Above loads achievable when used with a hardened rail 55 RC minimum 2.54 mm deep.

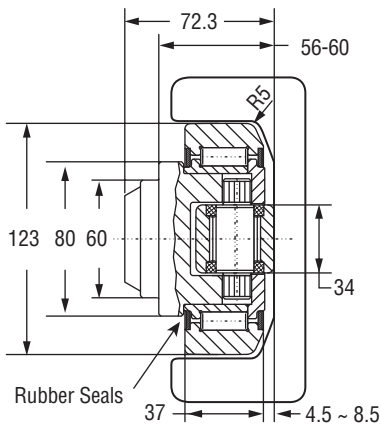

ECCENTRIC ADJUSTABLE

HVBEA-462/HVP4

WITH WELDED FLANGE PLATE

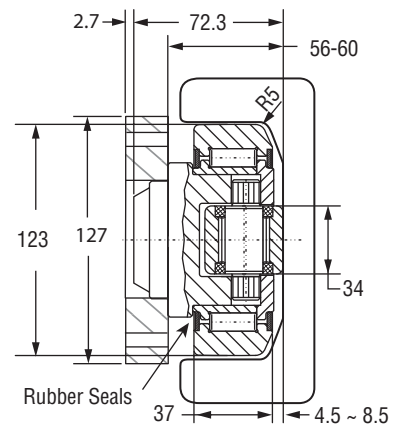

Download CAD

REDI-RAIL

COMMERCIAL RAIL

HARDENED CROWN ROLLER

V-GUIDE

HEVI-RAIL



3.81 US Ton-Force

HVB-062 **Hevi-Rail®**

RAIL – U CHANNEL HVR-5

Weight = 42.9 Kg/m

Moment of Inertia: $I_x = 205.84 \text{ cm}^4$; $I_y = 2185.32 \text{ cm}^4$

Moment of Resistance: $W_{x_{min}} = 48.42 \text{ cm}^3$;

$W_{x_{max}} = 86.89 \text{ cm}^3$; $W_y = 249.75 \text{ cm}^3$

Radius of Inertia: $i_x = 1.94 \text{ cm}$; $i_y = 6.32 \text{ cm}$

Distance to Center of Gravity: $e_y = 2.37 \text{ cm}$; $e_x = 8.75 \text{ cm}$

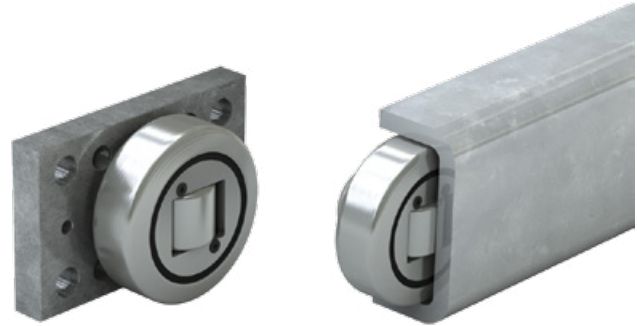
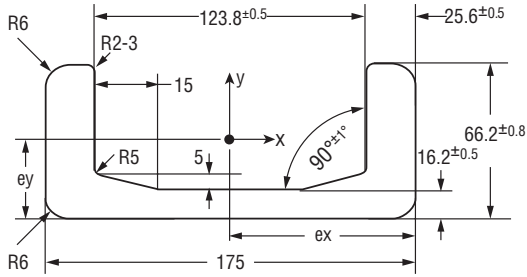

● **HEVI-RAIL BEARINGS**
Can be ordered with pre-welded flange plate

FLANGE PLATE HVP4-1

For ordering separate flange plate only

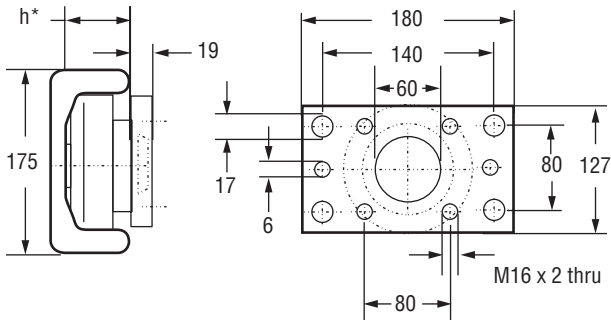

* Note: "h" refers to the depth of the axial bearing. This dimension depends on the choice of fixed axial bearing (HVB-062) or eccentric adjustable bearing (HVBEA-462).

ORDERING INFORMATION

| PART NUMBER | DESCRIPTION |
|----------------|---|
| HVB-062 | Fixed axial bearing |
| HVB-062/HVP4 | Fixed axial bearing with welded flange plate |
| HVBEA-462 | Eccentric adjustable axial bearing |
| HVBEA-462/HVP4 | Eccentric adjustable axial bearing with welded flange plate |
| HVP4-1 | Flange plate |
| HVR-5 | U-channel rail for -62 bearings |

REDI-RAIL

COMMERCIAL RAIL

HARDENED CROWN ROLLER

V-GUIDE

HEVI-RAIL



Hevi-Rail® HVB-063

6.65 US Ton-Force



AXIAL BEARING – FIXED HVB-063

Weight = 6.52 Kg

Maximum Bearing Loads:

Radial: Dynamic = 151 kN; Static = 192 kN

Axial: Dynamic = 68 kN; Static = 71 kN

Note: Above loads achievable when used with a hardened rail 55 RC minimum 2.54 mm deep.

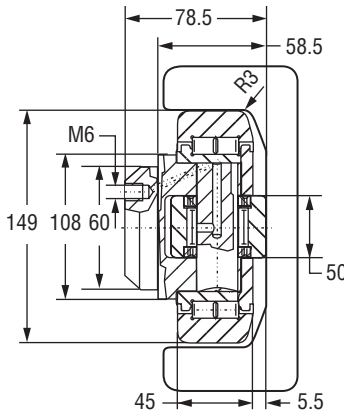

System Maximum Static Loads:

Radial: 59.2 kN / 6.65 US Ton-Force

Axial: 18.5 kN / 2.07 US Ton-Force

Note: Above loads are achievable when used with shown rails.



AXIAL BEARING – FIXED

HVB-063/HVP6

WITH WELDED FLANGE PLATE

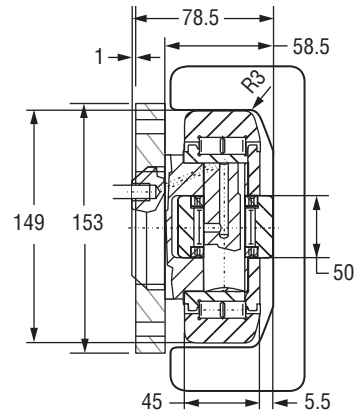

ECCENTRIC ADJUSTABLE HVBEA-463

Weight = 6.50 Kg

Maximum Bearing Loads:

Radial: Dynamic = 151 kN; Static = 192 kN

Axial: Dynamic = 68 kN; Static = 71 kN

Note: Above loads achievable when used with a hardened rail 55 RC minimum 2.54 mm deep.

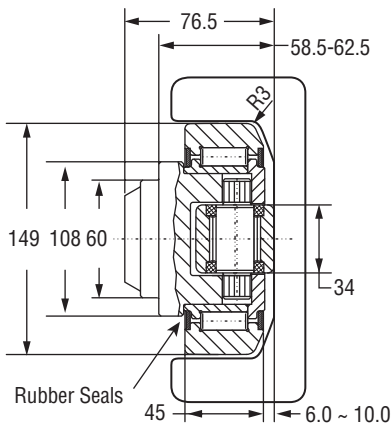

ECCENTRIC ADJUSTABLE

HVBEA-463/HVP6

WITH WELDED FLANGE PLATE

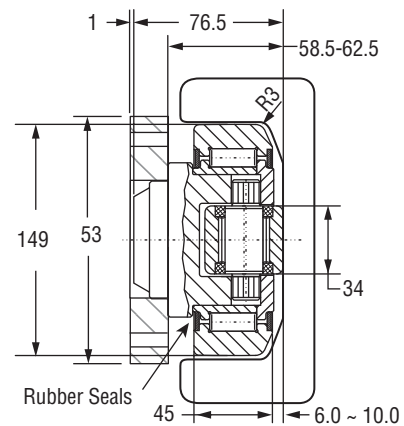

Download CAD

REDI-RAIL

COMMERCIAL RAIL

HARDENED CROWN ROLLER

V-GUIDE

HEVI-RAIL



6.65 US Ton-Force

HVB-063 Hevi-Rail®

RAIL – U CHANNEL HVR-6

Weight = 52.3 Kg/m

Moment of Inertia: $I_x = 269.52 \text{ cm}^4$; $I_y = 3423.08 \text{ cm}^4$

Moment of Resistance: $W_{x_{min}} = 57.15 \text{ cm}^3$;

$W_{x_{max}} = 112.11 \text{ cm}^3$; $W_y = 339.76 \text{ cm}^3$

Radius of Inertia: $i_x = 2.01 \text{ cm}$; $i_y = 7.17 \text{ cm}$

Distance to Center of Gravity: $e_y = 2.40 \text{ cm}$; $e_x = 10.08 \text{ cm}$

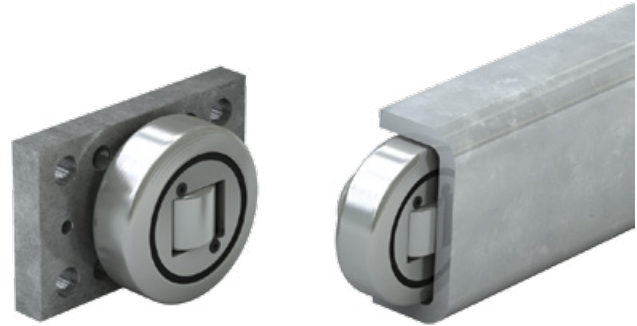
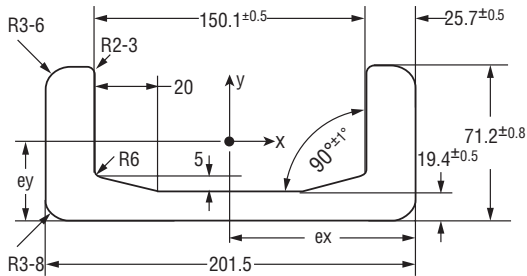

● **HEVI-RAIL BEARINGS**
Can be ordered with pre-welded flange plate

FLANGE PLATE HVP6-1

For ordering separate flange plate only

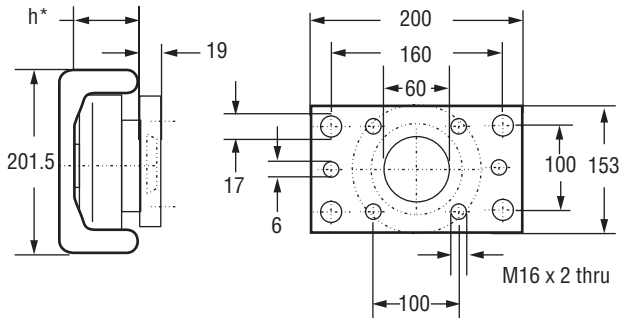

* Note: "h" refers to the depth of the axial bearing. This dimension depends on the choice of fixed axial bearing (HVB-063) or eccentric adjustable bearing (HVBEA-463).

ORDERING INFORMATION

| PART NUMBER | DESCRIPTION |
|----------------|---|
| HVB-063 | Fixed axial bearing |
| HVB-063/HVP6 | Fixed axial bearing with welded flange plate |
| HVBEA-463 | Eccentric adjustable axial bearing |
| HVBEA-463/HVP6 | Eccentric adjustable axial bearing with welded flange plate |
| HVP6-1 | Flange plate |
| HVR-6 | U-channel rail for -63 bearings |

REDI-RAIL

COMMERCIAL RAIL

HARDENED CROWN ROLLER

V-GUIDE

HEVI-RAIL



Technical

Static Loading Calculations

| | | | | |
|-----------|-----------------|-----------------------|---------|-----------|
| REDI-RAIL | COMMERCIAL RAIL | HARDENED CROWN ROLLER | V-GUIDE | HEVI-RAIL |
|-----------|-----------------|-----------------------|---------|-----------|

The load applied to a linear system can vary in many ways. Factors such as the center of gravity, drive or thrust location, forces of inertia at start and stop, need to be calculated to ensure the proper rail and carriage are applied.

HORIZONTAL MOTION - SINGLE RAIL

Load on the sliders:

$$P_1 = P_2 + F \quad P_2 = F \cdot \frac{a}{b}$$

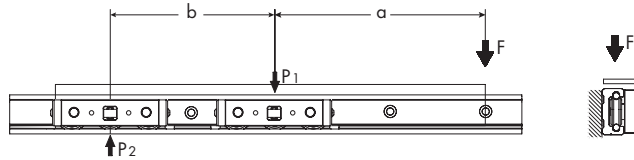

HORIZONTAL MOTION - SINGLE RAIL

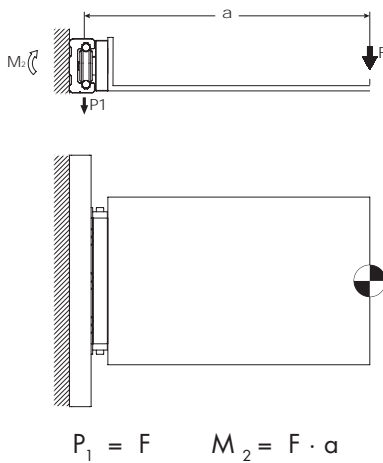

VERTICAL MOTION - SINGLE RAIL

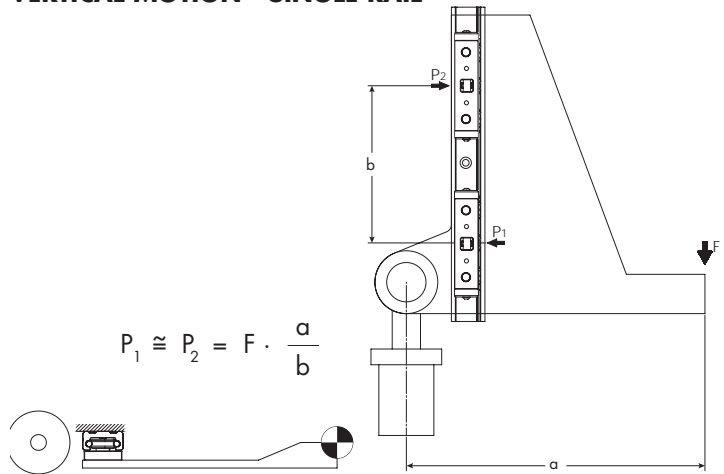

HORIZONTAL MOTION - SINGLE RAIL

Verification when change of direction affects inertial forces.

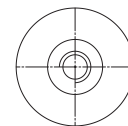
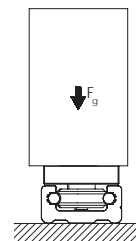
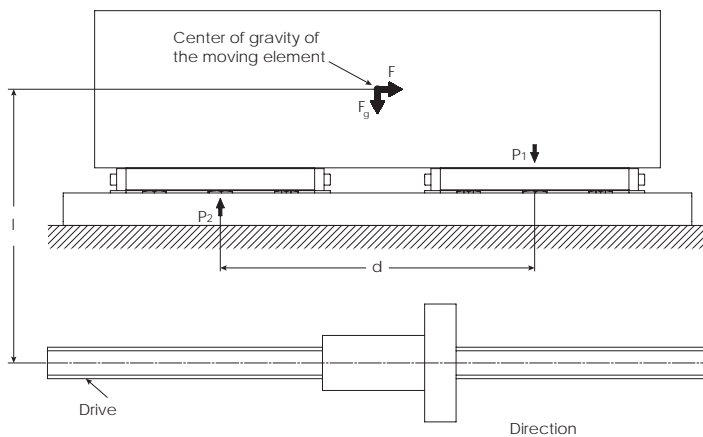

Explanation of the calculation formula

- F = effective force (N)
- Fg = weight-force (N)
- P1, P2, P3, P4 = effective load on the slider (N)
- M1, M2 = effective moment (N-m)
- m = mass (kg)
- a = acceleration (m/s²)

Inertial force

$$F = m \cdot a$$

Slider load at time of reverse

$$P_1 = \frac{F \cdot l}{d} + \frac{F_g}{2} \quad P_2 = \frac{F_g}{2} - \frac{F \cdot l}{d}$$



Static Loading Calculations

Technical

| | | | | |
|-----------|-----------------|-----------------------|---------|-----------|
| REDI-RAIL | COMMERCIAL RAIL | HARDENED CROWN ROLLER | V-GUIDE | HEVI-RAIL |
|-----------|-----------------|-----------------------|---------|-----------|

HORIZONTAL MOTION - PARALLEL RAILS / 2 SLIDERS

Load on the sliders:

$$P_1 = F \cdot \frac{b}{a+b} \quad P_2 = F - P_1$$

Additional moment load on slider:

$$M_1 = \frac{F}{2} \cdot c$$

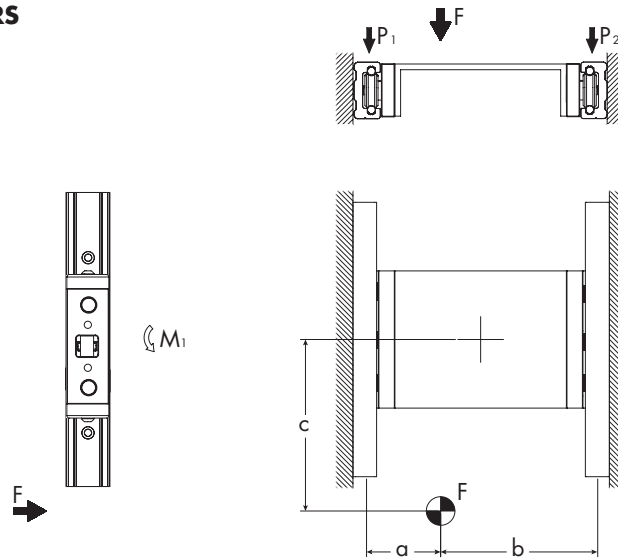

HORIZONTAL MOTION - PARALLEL RAILS / 4 SLIDERS

$$P_1 = \frac{F}{4} - \left(\frac{F}{2} \cdot \frac{b}{c} \right) - \left(\frac{F}{2} \cdot \frac{a}{d} \right)$$

$$P_2 = \frac{F}{4} - \left(\frac{F}{2} \cdot \frac{b}{c} \right) + \left(\frac{F}{2} \cdot \frac{a}{d} \right)$$

$$P_3 = \frac{F}{4} + \left(\frac{F}{2} \cdot \frac{b}{c} \right) - \left(\frac{F}{2} \cdot \frac{a}{d} \right)$$

$$P_4 = \frac{F}{4} + \left(\frac{F}{2} \cdot \frac{b}{c} \right) + \left(\frac{F}{2} \cdot \frac{a}{d} \right)$$

Slider #4 (P_4) should always be nearest to the point of the load

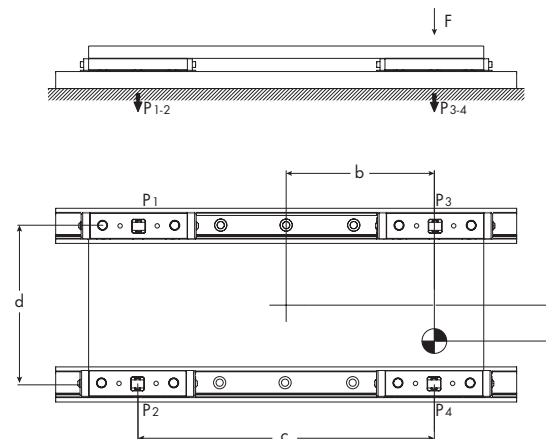

HORIZONTAL MOTION - PARALLEL RAILS / 2 SLIDERS

Load on the sliders:

$$P_{1a} \cong P_{2a} = \frac{F}{2}$$

$$P_{2b} \cong P_{1b} = F \cdot \frac{a}{b}$$

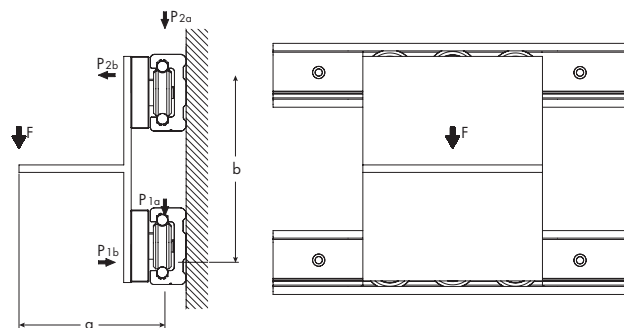



Technical

Static Loading Calculations

| | | | | |
|-----------|-----------------|-----------------------|---------|-----------|
| REDI-RAIL | COMMERCIAL RAIL | HARDENED CROWN ROLLER | V-GUIDE | HEVI-RAIL |
|-----------|-----------------|-----------------------|---------|-----------|

Use the values from the static load maximums given in the charts beginning on page 6 in the calculations below to verify acceptable loading conditions.

Calculation Factors:

- Fza and Fya are the radial and axial results of external forces in newtons (N).
- Mxa, Mya, and Mza are the external moments being applied in newton-meters (N-m).
- Fy, Fz, Mx, My, Mz are the load ratings for various directions and moments.
- s.f. is the relative safety factor as applied from the table below.

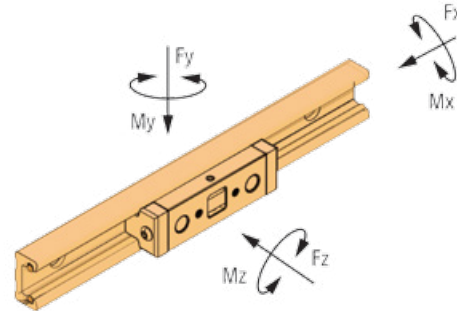

SINGLE LOAD FORCE CALCULATIONS

| | | | | |
|-----------------------------------|-----------------------------------|-----------------------------------|-----------------------------------|-----------------------------------|
| $\frac{Fza}{Fz} < \frac{1}{s.f.}$ | $\frac{Fya}{Fy} < \frac{1}{s.f.}$ | $\frac{Mxa}{Mx} < \frac{1}{s.f.}$ | $\frac{Mya}{My} < \frac{1}{s.f.}$ | $\frac{Mza}{Mz} < \frac{1}{s.f.}$ |
|-----------------------------------|-----------------------------------|-----------------------------------|-----------------------------------|-----------------------------------|

MULTIPLE LOAD FORCE CALCULATION

$$\frac{Fza}{Fz} + \frac{Fya}{Fy} + \frac{Mxa}{Mx} + \frac{Mya}{My} + \frac{Mza}{Mz} < \frac{1}{s.f.}$$

CALCULATION FACTORS

Use the following variables with the equations below to calculate the approximate travel life of Redi-Rail sliders under various loading conditions.

- L = Estimated travel life in meters (m).
- Fza and Fya are the axial and radial results of applied external forces in newtons (N).
- Mxa, Mya, and Mza are the external moments being applied in newton-meters (Nm).
- Fd is the dynamic slider capacity constant from the charts beginning on page 6.
- Fy, Fz, Mx, My, Mz are the load ratings for various directions and moments as found beginning on page 6.
- s.f. is the relative safety factor from the table below.

WEQV is the total radial load found from the equation:

$$WEQV = Fz \cdot \left(\frac{Fza}{Fz} + \frac{Mxa}{Mx} + \frac{Mya}{My} + \frac{Mza}{Mz} \right) + Fya$$

Life Calculation:

$$L = \left(Fd / WEQV \cdot s.f. \right)^3 \times 100,000 \text{ meters}$$

SAFETY FACTOR

- Use the "s.f." Safety Factor to adjust for dynamic forces and conditions particular to the application.

| APPLICATION CONDITION | s.f. SAFETY FACTOR |
|--|--------------------|
| Consistently smooth motion with low frequency of travel reversal, slow speed (<30% max.), no shock load or vibration, no elastic yield or deformation, clean environment | 1 – 1.5 |
| Normal assembly or shop floor conditions, moderate speed (30% max. to 75% max.), normal shock or vibration conditions | 1.5 – 2 |
| Frequent reversal of travel, high speeds (>75% max.), shock loads and/or vibration present, high elastic yield or deformation, heavy dirt and dust in environment | 2 – 3.5 |



Static Loading Calculations

Technical

| REDI-RAIL | COMMERCIAL RAIL | HARDENED CROWN ROLLER | V-GUIDE | HEVI-RAIL |
|-----------|-----------------|-----------------------|---------|-----------|
|-----------|-----------------|-----------------------|---------|-----------|

LOAD CALCULATIONS

L = applied load / number of wheel pairs
 L_R = wheel radial load
 L_O = wheel load from moment
 A = load offset dimension

B = track width dimension
 F_A = .5 for light duty, well lubricated use
 F_A = 1 for normal lubricated use
 F_A = 2 for dry, or harsh environments

HORIZONTAL MOTION - CENTER LOADED

$$L_{O1} = \frac{L \times (B - A)}{B} \times F_A \quad L_{O2} = (L \times F_A) - L_{O1}$$

Compare the greater of these loads to the rated moment and radial load capacities.

Example: Load is 100 lbs on 4 wheel carriage,
 L = 100 / 2 pair wheels = 50 lbs.
 A = 4", B = 10", F_A = 1
 $L_{O1} = \frac{50 \times (10 - 4)}{10} \times 1 = 30$ lbs.
 L_{O2} = 50 - 30 = 20 lbs.

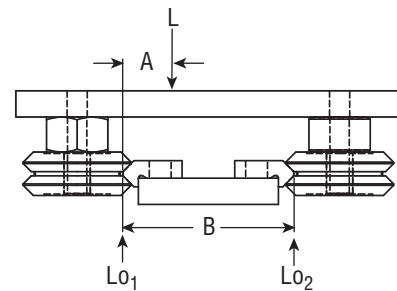

HORIZONTAL MOTION - OVERHUNG LOAD

$$L_{O1} = \frac{L \times A}{B} \times F_A \quad L_{O2} = (L \times F_A) + L_{O1}$$

Compare the greater of these loads to the rated moment and radial load capacities.

Example: Load is 100 lbs. on 4 wheel carriage,
 L = 100 / 2 pair wheels = 50 lbs.
 A = 4", B = 6", F_A = 1
 $L_{O1} = \frac{50 \times 4 \times 1}{6} = 33$ lbs.
 L_{O2} = 50 + 33 = 83 lbs.

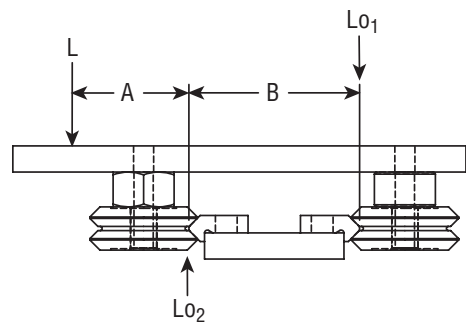

VERTICAL MOTION

$$L_{O1} = \frac{L \times A}{B} \times F_A \quad L_R = (L \times F_A) + L_{O1} \quad L_{O1} = L_{O2}$$

Compare the greater of these loads to the rated moment and radial load capacities.

Example: Load is 100 lbs. on 4 wheel carriage,
 L = 100 / 2 pair wheels = 50 lbs.
 A = 4", B = 6", F_A = 1
 $L_{O1} = \frac{50 \times 4 \times 1}{6} = 33$ lbs.
 L_R = (50 × 1) + 33 = 83 lbs.

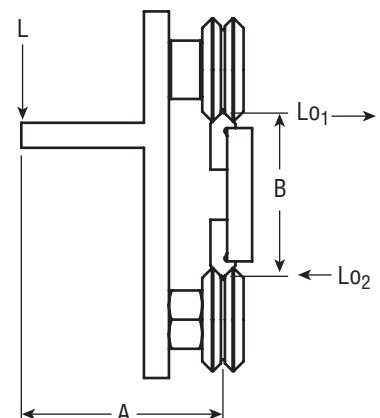



Technical

Specifications & Cantilevered Loads

| | | | | |
|-----------|-----------------|-----------------------|---------|-----------|
| REDI-RAIL | COMMERCIAL RAIL | HARDENED CROWN ROLLER | V-GUIDE | HEVI-RAIL |
|-----------|-----------------|-----------------------|---------|-----------|

TECHNICAL SPECIFICATIONS

Linear Bearing for Axial & Radial Loads

Prior to welding, disassemble bearing components. To avoid cracks in welded joints, please use welding electrodes and core weld for unalloyed steel.

MATERIALS

Outer ring – Case-hardened steel En 31 - SAE 52100 hardened at 60+2 HRC

Inner ring – Hardened steel En 31 - SAE 52100 hardened at 62-2 HRC

Cylindrical rollers – Flat ground heads are hardened steel, En 31 - SAE 52100, hardened at 59-64 HRC

Bolt tolerance = 0.05 mm

Profile rails – High Quality 18MnNb6 Steel at standard lengths of 6m (19.7 ft). Yield point of 430 N/mm², Tensile Strength of 550-770 N/mm². Rails are not hardened but have a Brinell hardness of 160-210. The guide ways in the rails should be lightly greased and not painted.

Clamp flange – Low carbon steel, adjustable clamp

Flange plate – Low carbon steel. Special designs available, contact manufacturer.

Seals – Bearings with fixed axial bearing (HVB-053 to HVB-063) - radial bearing has steel labyrinth and side guide roller with rubber seals.

Bearings with eccentric adjustable axial bearing (HVBEA-454 to HVBEA-463) - Both radial and axial bearings utilize rubber seals (RS type).

Lubrication – Bearings are supplied lubricated with grease grade 3. Bearings from HVB-055 to HVB-063 can be re-lubricated with grease zerk. Adjustable bearings are not available with zerk.

Temperature – Resistant from -30°C to 120°C (-22°F to 248°F)

Bearing Life Calculations:

$$L_{10} = \left(\frac{16667}{n} \right) \left(\frac{C}{P} \right)^{10/3} \text{ (Hours)}$$

C = Dynamic load rating (kN)

P = Automatic dynamic load (kN)

n = Revolutions per minute (rpm)

Note: Above calculation formula is for predicting life expectancy with 90% reliability level. Customers shall use their discretion to determine the reduction factor based on the actual operation needs and conditions such as reliability level, load, speed, impact and environments.

Adjusting Axial Bearings

1. Remove front screws.
2. Rotate axial bearing shaft (see diagram below)
3. Check dimension A (repeat step 2, if needed)
4. Re-install front screws
5. Recommend use of a breakable Loctite®.

[Link to video "How to Adjust Hevi-Rail Bearing Systems"](#)

CALCULATION OF FMAX FOR CANTILEVERED LOADS

Q = Load capacity (N)

L = Load distance to suspension point (mm)

P = Suspension point

A = Bearing distance (mm) recommended 500–1000 mm

$$\text{Formula: } F_{\max \text{ stat radial}} [N] = \frac{Q \cdot L}{2 \cdot A}$$

Max. Hertzian = 850 N/mm² for all profile rails.

Indicated here are F_{\max} stat radial + axial for each bearing.

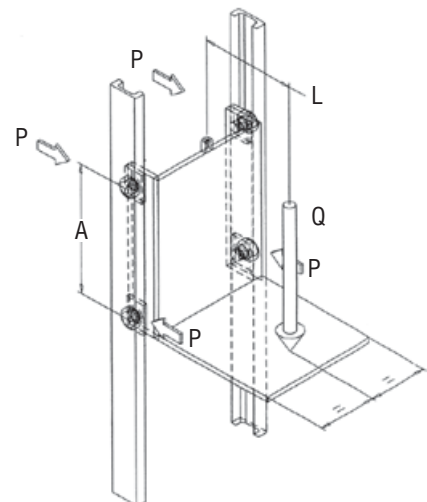
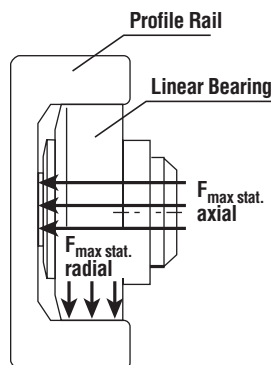

TECHNICAL



Mounting

Technical



MOUNTING CONFIGURATIONS

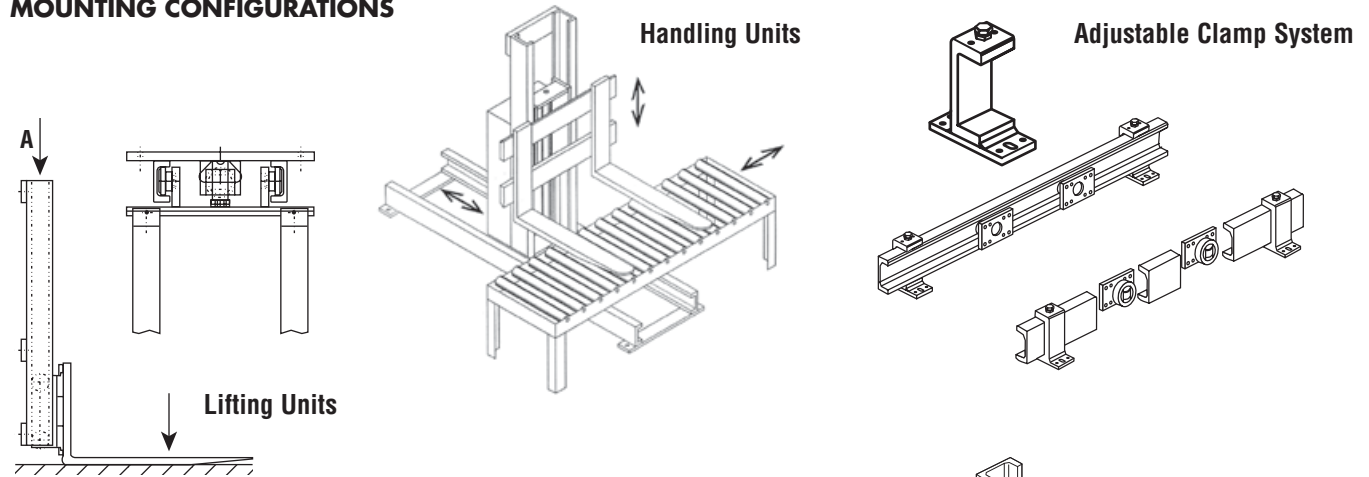

Horizontal Telescope

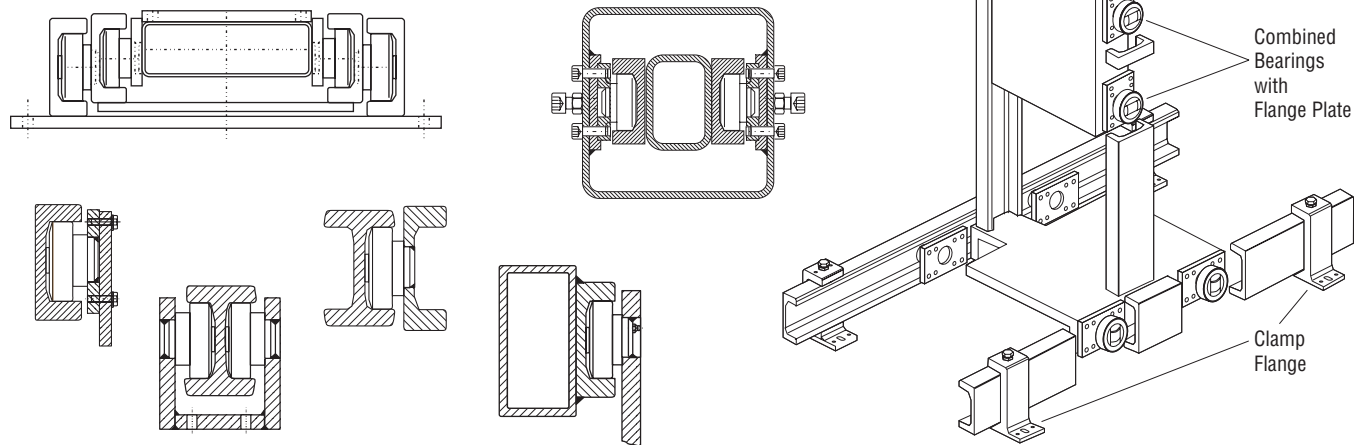

MOUNTING INSTRUCTIONS

1. The overall system clearance should be 1.524 mm to 3.048 mm
 $\text{Inner Rail Distance} = \text{Saddle Width} + (1.524 \text{ mm to } 3.048 \text{ mm})$

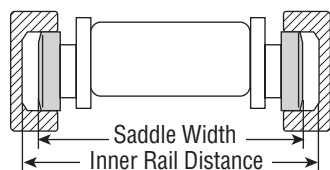

2. Verify that the Axial bearing is aligned parallel to the rail; especially in vertical operations.





Technical

Life Calculation

REDI-RAIL

COMMERCIAL RAIL

HARDENED CROWN ROLLER

V-GUIDE

HEVI-RAIL

IMPORTANT NOTICE ABOUT LIFETIME CALCULATIONS

There is no known formula for accurately and reliably calculating the *actual* lifetime of a linear or rotary bearing system.

The formulas within this section are solely based upon the statistical probability of success. It is important to recognize and distinguish between formulas of absolute certainty and probability.

Even though these formulas are not absolutely certain, they have been generally accepted as the best available method for determining bearing lifetime by the International Organization for Standardization (ISO) as well as its membership bodies; including, but not limited to: American National Standards Institute (ANSI), Deutsches Institut für Normung (DIN) & Japanese Industrial Standards Committee (JISC).

STATIC & DYNAMIC LOAD RATINGS

PBC Linear uses the two internationally accepted methods for calculating the Rated Lifetime, Static and Dynamic Capacities. Per the international standard, all lifetimes are calculated to an L_{10} life of 100 km (10^5 meters or ≈ 3.94 million inches). The two standards used are:

- ISO76 Rolling Bearings – Static Load Ratings
- ISO281 Rolling Bearings – Dynamic Load Ratings & Rating Life

Note: Some suppliers may choose to rate their bearings based upon a useful life of less than 100 km or a probability of success less than 90%. This causes their bearings to falsely appear to have a higher static and dynamic load capacity. If a catalog does not specifically note $L_{10} = 100$ km, caution should be used when comparing load capacity or life values between suppliers. The most commonly used values are $L_{10} = 50$ km and $L_{25} = 50$ km. For comparison, at $L_{10} = 100$ km, an example bearing has a maximum static load of 1,000 N. That exact same bearing as an $L_{10} = 50$ km maximum static load of $\approx 2,300$ N and an $L_{25} = 50$ km maximum static load of $\approx 4,600$ N!

In summary, the static load ratings are defined as the maximum applied load (or moment) which will result in the permanent deformation which does not exceed 1/10,000 of the diameter of the rolling element (ball or rod) within the bearing. The basic dynamic load rating, C , is the load of a constant magnitude and direction which a sufficiently large number of apparently identical bearings can endure for a basic rating life of one million revolutions. It's important to note that both the static and dynamic values are determined through ISO-Approved formulas. These formulas take into account several factors, including the design, internal geometry, material type, material quality and lubrication type.

Note: Additional factors are provided so that the estimated lifetime (default = 100 km) and/or the probability of success (default = 90%) can be changed from their default value to any desired value.

OPERATING LIFETIME

The "Operating Life" (or Operating Lifetime) is the actual life achieved by a rolling bearing. The actual lifetime typically varies from the calculated lifetime, sometimes significantly. It is not possible to accurately and reliably determine the actual Operating Life through calculations due to the large variety of operating and installation conditions. The most reliable method to achieve an approximation is by comparing the current application to similar applications. Primary factors which can negatively affect the life and are generally not included in calculations are:

- Contamination within the application
- Inadequate or improper lubrication
- Operational conditions different from calculated values, including unexpected forces and moments
- Insufficient and/or excessive operating clearance between the roller & guideway
- Excessive interference between roller & guideway (typically due to misalignment or excessive preload)
- Temperature out of range
- High shock loads (exceeding static load capacity)
- Vibration (which causes false brinelling resulting from fretting)
- Short stroke reciprocating motion (also causes False Brinelling)
- Damage caused during installation or from improper handling
- Improper mating surface hardness (when not used with a PBC Linear rail)



Life Calculation

Technical

| REDI-RAIL | COMMERCIAL RAIL | HARDENED CROWN ROLLER | V-GUIDE | HEVI-RAIL |
|-----------|-----------------|-----------------------|---------|-----------|
|-----------|-----------------|-----------------------|---------|-----------|

TERMS, DEFINITIONS AND SYMBOLS

The following variables are used within the equations listed on the following pages.

- F_{y_app} = Force applied in the Y direction (radial force), N
- F_{z_app} = Force applied in the Z direction (axial force), N
- M_{x_app} = Moment applied about the X axis, N
- M_{y_app} = Moment applied about the Y axis, N
- M_{z_app} = Moment applied about the Z axis, N
- F_{y_max} = Maximum allowable force in the Y direction (radial force), N
- F_{z_max} = Maximum allowable force in the Z direction (axial force), N
- M_{x_max} = Maximum allowable moment about the X axis, N · m
- M_{y_max} = Maximum allowable moment about the Y axis, N · m
- M_{z_max} = Maximum allowable moment about the Z axis, N · m
- D_a = Rolling contact diameter, from product tables, mm
- f_H = Shaft (rail) hardness reduction factor
- f_L = Required Lifetime (km) reduction factor
- f_R = Reliability reduction factor
- f_{SS} = Short stroke reduction factor
- L₁₀ = Basic rating life, km (10³ m)
- Pr = Equivalent radial (F_y) load, N
- s.f. = safety factor

Note: PBC has chosen to depart from the nomenclature standards used by ISO. Instead, PBC uses a convention which is more in line with other PBC products. This ensures that all PBC products use the same naming conventions, making it easier to compare multiple products from different product families.

The Y direction (radial force) and Z direction (axial force) are dependant upon the orientation of the wheel bearing.

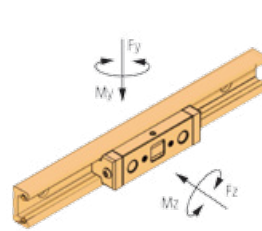

- F_d = Dynamic capacity (LC)
- F_z = Axial capacity
- F_y = Radial capacity
- M_x, M_y, M_z = Moment capacities

Conversions

- newton (N) x 0.2248 = lbs.
- (lbf) meter x 0.0397 = inch
- newton - meter (N-m) x 8.851 = in.-lbs.

DERIVATION

The lifetime formula within ISO 281 gives the life in millions of revolutions. The conversion from rotary life to linear life is done using the conversion factors listed in the following three equations. This derivation applies to both individual rollers and carriages. L_{rev} and L_{distance} represent the lifetime of the bearing in revolutions and linear distance, respectively.

Note: Attention must be paid to units of measure, especially when considering products from different manufacturers. All of the lifetime formulas within this section yield results in kilometers; however, not all companies follow the same standard. Some companies may express life in meters or 100's of kilometers.

$$L_{Distance} [1 \cdot 10^5 m] = L_{rev} [1,000,000 rev] \cdot \left(3.14 D_a \left[\frac{mm}{rev} \right] \right) \cdot \left(\frac{1 \cdot 10^5 m}{100,000,000} \left[\frac{m}{mm} \right] \right) \quad \text{Eq. 1.}$$

$$L_{Distance} [1 \cdot 10^5 m] = L_{rev} \cdot (0.0314 D_a) \quad \text{Eq. 2.}$$

$$L_{Distance} [km] = 100 \cdot L_{rev} \cdot (0.0314 D_a) = 3.14 \cdot D_a \cdot L_{rev} \quad \text{Eq. 3.}$$



[Link to whitepaper "The Facts About Roller Bearing Life Calculations"](#)



Technical

Life Calculation

| | | | | |
|-----------|-----------------|-----------------------|---------|-----------|
| REDI-RAIL | COMMERCIAL RAIL | HARDENED CROWN ROLLER | V-GUIDE | HEVI-RAIL |
|-----------|-----------------|-----------------------|---------|-----------|

INDIVIDUAL ROLLERS – ALL PRODUCTS EXCEPT HEVI-RAIL ROLLERS

Most of the individual rollers within this catalog are Radial Ball Bearings. The following formulas should be used for all individual bearings **except Hevi-Rail** bearings (which are roller bearings). This formula calculates the basic rating life (L_{10} life), which does not take into account any reduction factors based upon the application.

$$L_{10} [km] = 3.14 \cdot D_a \cdot \left(f_L \cdot f_H \cdot f_{SS} \cdot \frac{F_{y_{max}}}{P_r} \right)^3 \cdot (f_R) \quad \text{Eq. 4.}$$

$$P_r = X \cdot F_{y_{app}} + Y \cdot F_{z_{app}} \quad \text{Eq. 5.}$$

The values for X & Y can be found using the table listed below.

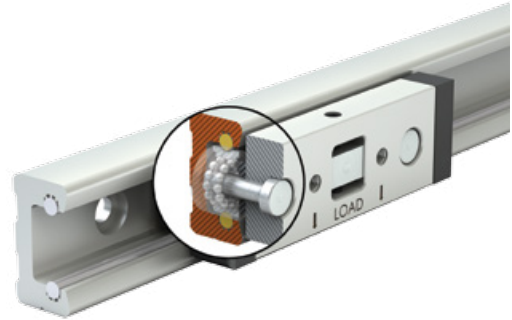

INDIVIDUAL ROLLERS – HEVI-RAIL ROLLERS

Hevi-Rail bearings are roller bearings, as opposed to radial ball bearings. The formulas are very similar to the formulas shown above, with only some minor changes.

Note: Hevi-Rail rollers are combined bearings. Essentially there are two bearings combined into one. Life calculations should be performed for both the radial and the axial bearing.

$$L_{r_{10}} [km] = 3.14 \cdot D_a \cdot \left(f_L \cdot f_H \cdot f_{SS} \cdot \frac{F_{y_{max}}}{P_r} \right)^{\frac{10}{3}} \cdot (f_R) \quad \text{Eq. 6.}$$

$$L_{a_{10}} [km] = 3.14 \cdot D_a \cdot \left(f_L \cdot f_H \cdot f_{SS} \cdot \frac{F_{y_{max}}}{P_z} \right)^{\frac{10}{3}} \cdot (f_R) \quad \text{Eq. 7.}$$



VALUES OF X & Y FOR RADIAL BALL BEARING LIFE FORMULA

| PRODUCT | $\frac{F_{z_{app}}}{F_{y_{app}}} \leq \epsilon$ | | $\frac{F_{z_{app}}}{F_{y_{app}}} > \epsilon$ | | ϵ |
|--|---|-----|--|------|------------|
| | X | Y | X | Y | |
| Commercial Rail (all sizes) | 1 | 0 | .41 | .87 | .68 |
| Hardened Crown Rollers | 1 | 0 | .41 | .87 | .68 |
| Integral-V (IVT) (Compact Linear Guides) | 1 | .78 | .63 | 1.24 | .8 |
| Integral-V (IVT) (all other sizes & types) | 1 | .78 | .63 | 1.24 | .8 |
| Redi-Rail (all sizes & types) | 1 | .78 | .63 | 1.24 | .8 |
| Steel-Rail (all sizes & types) | 1 | .78 | .63 | 1.24 | .8 |
| V-Rail (all sizes) | 1 | .78 | .63 | 1.24 | .8 |



Life Calculation

Technical

| | | | | |
|------------------|------------------------|------------------------------|----------------|------------------|
| REDI-RAIL | COMMERCIAL RAIL | HARDENED CROWN ROLLER | V-GUIDE | HEVI-RAIL |
|------------------|------------------------|------------------------------|----------------|------------------|

CARRIAGE (SLIDER) ASSEMBLIES

Formulas for calculating the estimated lifetime for carriage assemblies are fundamentally similar to the calculations for the individual rollers. The most accurate method for determining the life of a carriage (slider) assembly is to create a free body diagram for the carriage and determine the axial, radial and moment load applied to each individual roller. This method is cumbersome and is usually only required in the most severe of circumstances. In most cases, the carriage (slider) assembly can be treated as a rigid body and calculations can be completed based upon the load ratings for the entire carriage (slider).



$$L_{10} [km] = 100 \cdot \left(f_L \cdot f_H \cdot f_{SS} \cdot \left(\frac{F_{y\ app}}{F_{y\ max}} + \frac{F_{z\ app}}{F_{z\ max}} + \frac{M_{x\ app}}{M_{x\ max}} + \frac{M_{y\ app}}{M_{y\ max}} + \frac{M_{z\ app}}{M_{z\ max}} \right) \right)^3 \cdot (f_R) \quad \text{Eq. 8.}$$

SAFETY FACTOR

All individual rollers and carriages are subject to use a balancing formula which ensures an adequate product life. The following formulas should be used for all CRT Products.

$$\text{Carriages} \quad \frac{1}{s.f.} \geq \frac{F_{y\ app}}{F_{y\ max}} + \frac{F_{z\ app}}{F_{z\ max}} + \frac{M_{x\ app}}{M_{x\ max}} + \frac{M_{y\ app}}{M_{y\ max}} + \frac{M_{z\ app}}{M_{z\ max}} \quad \text{Eq. 9.}$$

$$\text{Individual Bearings} \quad \frac{1}{s.f.} \geq \frac{F_{y\ app}}{F_{y\ max}} + \frac{F_{z\ app}}{F_{z\ max}} \quad \text{Eq. 10.}$$

Where the safety factor value can be determined using the following table.

RECOMMENDATIONS FOR SAFETY FACTOR (s.f.)

| DUTY | SHOCK/VIBRATION | REVERSE FREQUENCY | CONTAMINATION | s.f. |
|------------|-----------------|-------------------|---------------|-----------|
| Very Light | None | Smooth & Low | None | 1.0 – 1.2 |
| Light | Light | Light | Light | 1.2 – 1.5 |
| Medium | Medium | Medium | Medium | 1.5 – 2.0 |
| Heavy | Heavy | High & Fast | Heavy | 2.0 – 3.5 |

Note: The table above contains suggested safety factors based upon the most commonly encountered adjustment criteria. Additional criteria may require raising the safety factor.

MINIMUM LOAD NOTICE

It is possible to apply too small of a load to a bearing/carriage. In this case, there is a possibility of the outer ring slipping or the roller lifting off the track. This can cause unexpected vibration or skidding which will reduce the life of the bearing. Therefore, the following condition should be met under dynamic load conditions.

$$\text{Minimum Dynamic Load} \rightarrow \frac{F_{y\ app}}{F_{y\ max}} \leq 50 \quad \text{Eq. 11.}$$

There is no minimum load requirement under static conditions.



Technical

Life Calculation

| | | | | |
|-----------|-----------------|-----------------------|---------|-----------|
| REDI-RAIL | COMMERCIAL RAIL | HARDENED CROWN ROLLER | V-GUIDE | HEVI-RAIL |
|-----------|-----------------|-----------------------|---------|-----------|

HEAVY LOAD NOTICE

It is also possible to over load the bearings. Extra-heavy loads can cause unexpected stress concentrations in the bearing or railway which reduce the actual lifetime below the minimally acceptable level. These stress concentrations typically come from unexpected vibration within the application or unexpectedly high preload forces caused by misalignment, damage or thermal expansion. In these cases, a larger safety factor should be used.

$$Use\ Caution \rightarrow P_r > 0.5 \cdot C_r \quad Eq. 12.$$

Note: Although typically applying to linear motion rolling bearings, ISO 14728-1 states that the above equation should be followed. It should be treated as a rule as opposed to a guideline.

If the product under consideration is a carriage (slider) assembly and $P_r > 0.5 \cdot C_r$, then it is recommended to consider the axial, radial and moment load applied to each individual roller to ensure each roller still has an adequate safety factor.

SHAFT/RAIL HARDNESS FACTOR, f_H

It is possible to use a softer rail material in combination with PBC Linear's CRT products; however, it is necessary to reduce the static and dynamic load capacities of each product. The reduced load capacity is known as the "Effective Load Capacity". This value can be calculated using the formula below. The reduction factor, f_H , can be determined using the figure below.

$$Dynamic \rightarrow F_{Y_Eff} = F_Y \cdot f_H \quad Eq. 13.$$

$$Static \rightarrow F_{0Y_Eff} = F_{0Y} \cdot f_H \quad Eq. 14.$$

For easy reference, some of the most common materials have been plotted on the chart below. The circled numbers correspond to material types listed in the table below. Other material types can be used.

APPROXIMATE COMPARISON OF COMMON INTERNATIONAL MATERIALS¹

| # | TYPE | EN NAME | EN # | ASTM/AISI | TYPICAL HARDNESS ² | f_H |
|---|-----------------|-------------|--------|-----------|-------------------------------|----------|
| 1 | Steel | C60 | 1.0601 | 1060 | 60-62 | 1.0 |
| 2 | Steel | 52-3 | 1.0570 | 1024 | 19-22 | 0.1 |
| 3 | Stainless Steel | X46 Cr13 | 1.4034 | 420 | 51-53 | 0.7 |
| 4 | Stainless Steel | X90 CrMoV18 | 1.4112 | 440B | 53-55 | 0.8 |
| 5 | Stainless Steel | X105 CrMo17 | 1.4125 | 440C | 59-61 | 0.95-1.0 |

Note: The values listed in the above table should be considered for reference only. It is critical that individual suppliers are contacted to ensure an accurate hardness rating. Depending upon the supplier, "hardness" can actually be the minimum, maximum, or average value. The wrong interpretation can have unexpected consequences for the application. When given the choice, PBC recommends using the "minimum hardness" when determining the reduction factor as this is the most conservative method.

- Material Types may not be an exact match. PBC Linear has carefully reviewed the material standards and has determined that if there is not an exact match; the listed materials are the closest approximation. A material specialist should be consulted before translating one material type to another.
- Different suppliers may have alternate ranges for material hardness, depending upon their heat treating process. Consult manufacturer's specifications for a more exact number/range.

Static & Dynamic Reduction Factors for Lower Raceway Hardness

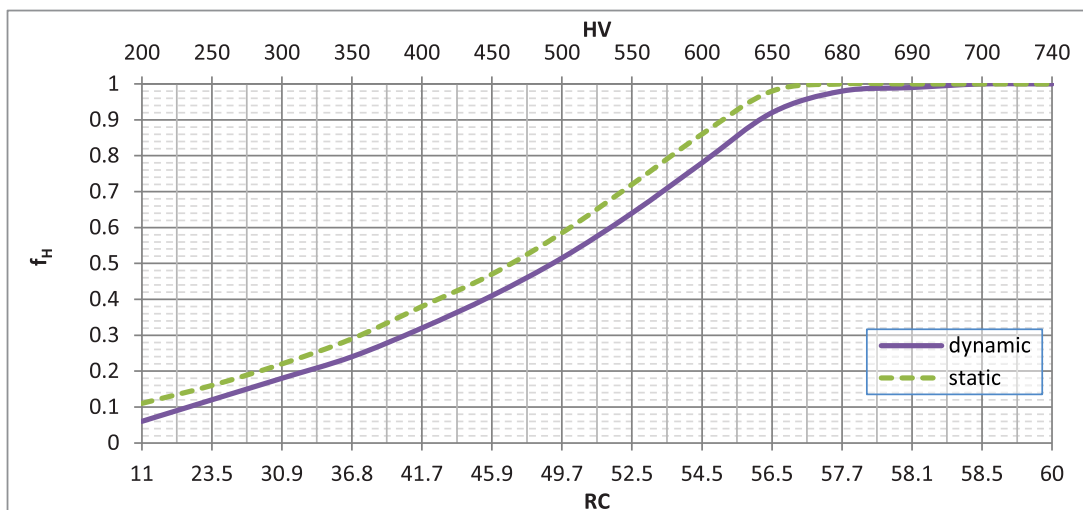



Life Calculation

Technical

| | | | | |
|------------------|------------------------|------------------------------|----------------|------------------|
| REDI-RAIL | COMMERCIAL RAIL | HARDENED CROWN ROLLER | V-GUIDE | HEVI-RAIL |
|------------------|------------------------|------------------------------|----------------|------------------|

REQUIRED LIFETIME (km) FACTOR, f_L

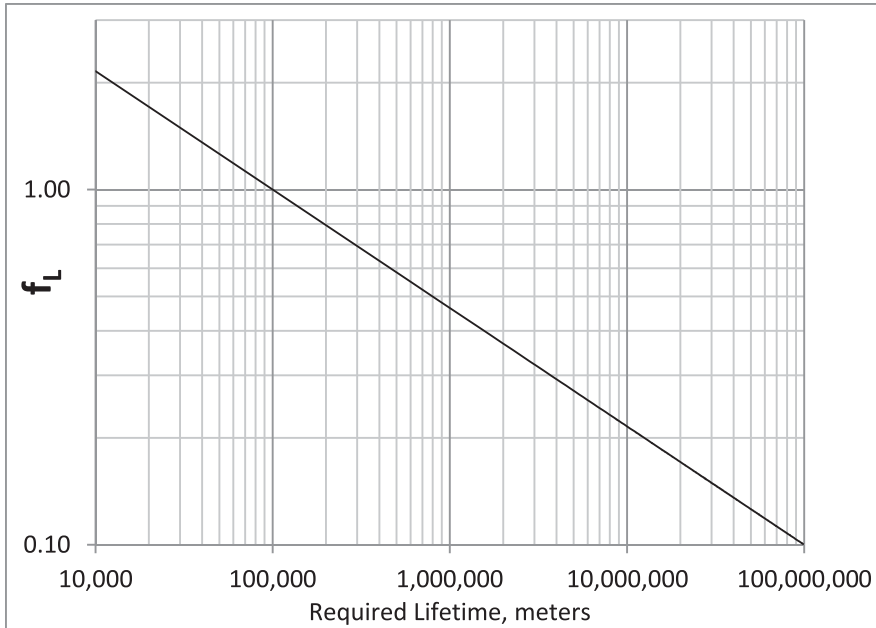

The standard lifetime formulas listed within this catalog describe an L10 life based upon 100 km, in accordance to the applicable ISO standards. Sometimes 100 km is either excessive or shy of the target life of a machine and the required lifetime needs to be adjusted. An appropriate adjustment factor can be found using the chart.

RELIABILITY FACTOR, f_R

| RELIABILITY | L_n | f_R |
|-------------|------------|-------|
| 50% | L_{50} | 5.04 |
| 60% | L_{40} | 3.83 |
| 70% | L_{30} | 2.77 |
| 80% | L_{20} | 1.82 |
| 90% | L_{10} | 1.0 |
| 95% | L_5 | 0.64 |
| 96% | L_4 | 0.55 |
| 97% | L_3 | 0.47 |
| 98% | L_2 | 0.37 |
| 99.0% | L_1 | 0.25 |
| 99.2% | $L_{0.8}$ | 0.22 |
| 99.4% | $L_{0.6}$ | 0.19 |
| 99.6% | $L_{0.4}$ | 0.16 |
| 99.8% | $L_{0.2}$ | 0.12 |
| 99.9% | $L_{0.1}$ | 0.093 |
| 99.92% | $L_{0.08}$ | 0.087 |
| 99.94% | $L_{0.06}$ | 0.080 |
| 99.95% | $L_{0.05}$ | 0.077 |

The L10 Life Formulas are a statistical probability formula with a success rate of 90%. Sometimes an L10 life (90% success) is just not good enough and the formulas need to be modified in order to have a higher probability of success. In this case, choose the desired reliability rate and insert the f_R value into the life equation.



Technical

Life Calculation

| | | | | |
|-----------|-----------------|-----------------------|---------|-----------|
| REDI-RAIL | COMMERCIAL RAIL | HARDENED CROWN ROLLER | V-GUIDE | HEVI-RAIL |
|-----------|-----------------|-----------------------|---------|-----------|

SHORT STROKE FACTOR, f_{ss}

In the case that the travel distance is low, a short stroke reduction factor must be included. In general, this factor only applies when the stroke is less than 2x the carriage length. In the case of individual bearings, use 2 full revolutions of the bearing.

$$\text{Stroke Ratio, carriage (slider)} = \frac{\text{stroke [mm]}}{\text{carriage length [mm]}} \quad \text{Eq. 15.}$$

$$\text{Stroke Ratio, individual bearing} = \frac{\text{stroke [mm]}}{\pi D_p \text{ [mm]}} \quad \text{Eq. 16.}$$

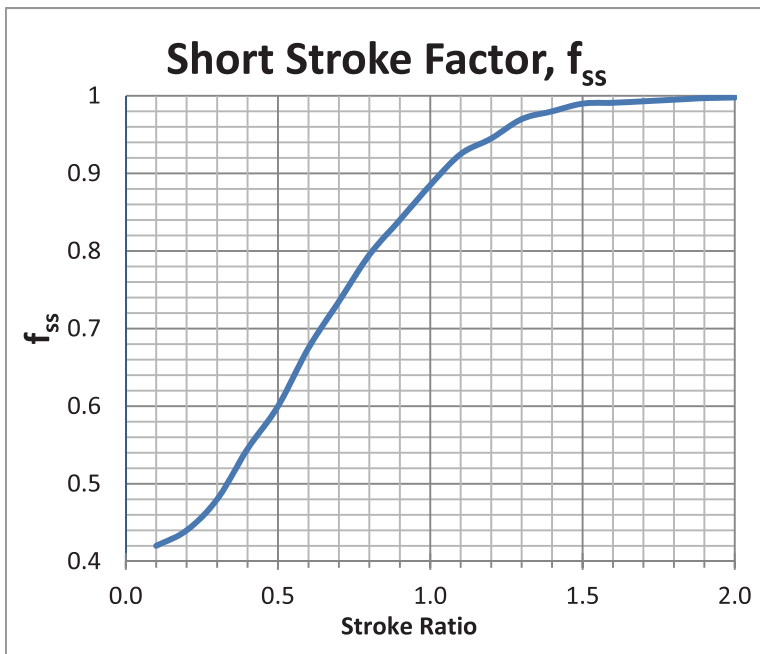

Short Stroke Correction Factor



Installation

Technical

| REDI-RAIL | COMMERCIAL RAIL | HARDENED CROWN ROLLER | V-GUIDE | HEVI-RAIL |
|-----------|-----------------|-----------------------|---------|-----------|
|-----------|-----------------|-----------------------|---------|-----------|

GENERAL INSTALLATION

As a general rule, all of the products within the catalog have a higher radial (F_y) than axial (F_z) load capacity. Whenever possible, designers should attempt to orient the bearings so the primary applied load is in the radial direction.

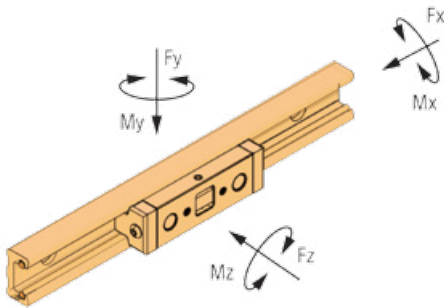

COMMERCIAL RAIL

Commercial Rail is typically used in applications which require low to moderate accuracy. It is generally not necessary to use any advanced manufacturing or assembly techniques to secure this rail system into place.

Note: If an assembly plan requires Commercial Rail rails to be installed with dial indicators, calipers or other sensitive measuring equipment, then likely this product has probably been over-specified for an application. Consider using a more accurate product for these applications, such as the V-Guide System, Redi-Rail, Integral-V (IVT), or Steel Rail.

HARDENED CROWN ROLLER RAIL

Hardened Crown Rollers are typically used in applications which require low accuracy. The railway is typically clamped or welded into place. For more information on recommended welding procedures, see the Hevi-Rail section.

Note: If an assembly plan requires Hardened Crown Roller rails to be installed with dial indicators, calipers or other sensitive measuring equipment, then it is likely this product has probably been over-specified for an application. Consider using a more accurate product in these applications, such as the V-Guide System, Integral-V (IVT), Redi-Rail, or Flexible Steel Rail.

REDI-RAIL

The Redi-Rail product is very versatile and can be used in applications that require low accuracy or applications that require moderate-high accuracy. In applications that require low accuracy, no special installation and alignment procedures are required. In applications that require moderate to high accuracy, use advanced assembly techniques similar to those used for installing profile rail guideways.

Note: Refer to the PRT (Profile Rail Technology) catalog for more detailed information related to advanced assembly techniques.

HEVI-RAIL

Hevi-Rail is typically used in applications which require moderate accuracy. There are two common methods for installing Hevi-Rail: Welding & Clamp Flanges.

Welding

The preferred method of welding Hevi-Rail, Flange Plates and Hevi-Rail Clamp Flanges is MIG Welding. Please follow the guidelines listed below when MIG welding Hevi-Rail, Flange Plates, and Hevi-Rail Clamp Flanges.

1. Use a metal brush or grinder to remove rust or paint from surface to be welded.
2. Bevel joint edges on metals thicker than 3/8" to ensure the weld fully penetrates to the base of the metal. (HVR-2, HVR-3, HVR-4, HVR-5 HVR-6, HVRI-08, HVRI-09, HVRI-10, HVRI-11.)
3. Ensure that grounding clamp is engaged in clean metal.
4. When welding HVR-S, HVR-0, HVR-1, HVRI-07 sections of Hevi-Rail it is recommended to use .03" diameter wire. A preferable grade wire for mild steel is ER70S-3
5. When welding thick sections of Hevi-Rail, it is recommended to use .035"-.045" ER70S-3 wire. Weld at a higher heat level to obtain a deep penetration. This is recommended for HVR-2, HVR-3, HVR-4, HVR-5 HVR-6, HVRI-08, HVRI-09, HVRI-10, and HVRI-11.
6. A 75% Argon/25% Carbon Dioxide mix is a preferable general purpose shielding gas when welding mild steels like Hevi-Rail.
7. Know your load calculations, when in doubt meet with your structural or mechanical engineer.
8. Destructive testing facilities are recommended for testing weld strength. Periodic destructive testing ensures that the welding equipment and welding practices are yielding safe and strong welds.
9. NEVER weld a mild steel Hevi-Rail product to a dissimilar metal such as cast iron, or stainless steel.

CLAMP FLANGES

When using bolts to hold a Clamp Flange to Hevi-Rail HVR1, HVR-2, HVR-3, HVR-4, HVR-5 HVR-6, it is recommend to drill a detent in the top of the rail where the screw seats. Many customers use a drill point smaller than the minor diameter of the tap diameter to put a point in the rail. This is preferred in systems that have vibrations and harmonics in its environment. Some customers use bolts to align and assemble the system, then weld the clamp to the rail.



Technical

Installation

REDI-RAIL

COMMERCIAL RAIL

HARDENED CROWN ROLLER

V-GUIDE

HEVI-RAIL

V-GUIDE

V-Rail is typically used in applications which require low to moderate accuracy. The installation accuracy is primarily limited by the accuracy of the mounting surface. It is possible to successfully install V-Rail onto as-extruded bars and plate, or to rolled metal bars/plates. These materials typically do not have very tight dimensional, parallelism, flatness, and straightness tolerances. The loose tolerances add to the overall tolerance stack-up which reduces the installation accuracy.

A higher grade of accuracy can be achieved by machining the mounting plate, typically through a milling or grinding process. Using machine tool design and assembly techniques, it is possible to achieve an accuracy rating as high as ± 0.025 mm (± 0.001 in). In this case, the mounting surface must be meticulously prepared, and reference edge or dowel pins should be used for alignment purposes.

Note: Integral-V (IVT) products eliminate this alignment process. If an application requires two parallel rails, PBC highly recommends the consideration of the IVT products. Customers have reported significant Total Installed Cost (TIC) savings that have been achieved through the use of IVT products.

GENERAL NOTES

Handling

Proper handling of PBC Linear products is critical to ensure specified product performance, product life and to prevent accidental injury. Some products come from the factory with a "clearance" type preload. These carriages will freely slide if the rail is not kept horizontal. Special attention must be paid when installing the rail overhead or in a vertical orientation.

Special care must also be given to long length units. Single point lifting some products may cause enough bend as to result in permanent, plastic deformation to the railway. Always use suitable lifting equipment which can provide enough support to minimize deflection.

Storage

Proper storage is critical in order to maintain an adequate product shelf life. If immediate installation is not possible or practical, it is best to store the product within the package provided by (or designated by) PBC Linear. The product and package should be stored in a horizontal orientation and environmental extremes (high temperature, low temperature, high humidity) should be avoided. It may be necessary to lubricate steel components during prolonged storage in order to prevent corrosion.

Securing Fasteners

PBC makes no specific recommendation as to whether or not thread-locking fluid (i.e. Loctite®), lock nuts, lock washers, etc., should be used within a given application. Sound engineering fundamentals and company policies should dictate the use of anti-vibration components and technology. Some common reference materials include, but are not limited to:

- Your company's policies and/or engineering specifications
- Marks's Standard Handbook for Mechanical Engineers, published by McGraw-Hill (English)
- Machinery's Handbook, published by Industrial Press (English)
- Roloff/Matek Maschinenelemente, published by Vieweg (German)

Fastener Quantity

It may not be necessary to use a fastener within every supplied fixing hole. This is especially true for applications carrying a light load (high factor of safety). Engineering statics equations can be used to determine the amount of deflection within a rail if not all fixing holes are used. Modern tools, such as FEA, can also be used to speed up this process.

Welding

The recommendations and guidelines listed herein are recommendations only. Always follow your specific company's policies, welding equipment manufacturer's instructions, guidelines established by national standards agencies (i.e. ANSI/DIN), city/state/federal laws or civil guidelines related to proper welding practices. Improper application or installation of PBC products can result in property damage, death or serious bodily injury.

Installing carriages with spring loaded lubricators

Note: Improper installation of carriages with spring-loaded lubricators can permanently damage the lubricator material. Damage caused by improper installation is not covered by PBC's warranty.

Initial Lubrication

After installation, follow the initial lubrication instructions located within this catalog or at www.pbclinear.com. All products are shipped with a preservative material which should not be considered a true, performance lubricant. Lubricant should be added before initial use.

Painting/Powder Coating

Most PBC products can be painted or powder coated after installation to match the aesthetic appearance of the parent structure. It is highly recommended that the bearing's raceway be masked during this process. These coatings will typically not withstand the pressure of a typical operation and will flake off. These flakes will act as "bumps" causing the rollers to experience unplanned vibration. This can cause an unexpected shortening of the life of the rollers/carriage.



Lubrication

Technical

| REDI-RAIL | COMMERCIAL RAIL | HARDENED CROWN ROLLER | V-GUIDE | HEVI-RAIL |
|-----------|-----------------|-----------------------|---------|-----------|
|-----------|-----------------|-----------------------|---------|-----------|

ROLLER LUBRICATION

All smaller rollers (in the Redi-Rail®, IVT™, V-Guide, Commercial Rail, Hardened Crown Roller families, and smaller diameter Hevi-Rail® bearings) are lubricated internally for long life. No additional lubrication is necessary. The rollers are sealed (or shielded) against the operating environment to prevent egress of lubricant, and prevent ingress of contaminants. Some larger rollers (in the Hevi-Rail family) are supplied with a grease access point and can be re-lubricated using a zerk fitting.

RACEWAY/GUIDEWAY LUBRICATION

To ensure long life, it is necessary to have a thin film of lubrication on the Raceway/Railway at all times. When properly applied, lubrication:

- Reduces wear
- Reduces stress on the contact surfaces
- Reduces friction (and therefore heat buildup)
- Allows for operation at specifications in this catalog (de-rating is required for un-lubricated applications)
- Helps protect the metal surfaces against corrosion (rust and fretting corrosion)

LUBRICATION TYPE

Technical, environmental, ecological and economic factors will determine whether oil or grease should be used in an application. One of the most significant factors in the lubrication selected is the environmental conditions. If extreme conditions are expected, it is highly recommended that a representative from a lubrication company is consulted. This includes heavy contamination, when the expected particle size is smaller than 0.1 mm (0.005 in) as small particles can more easily bypass seals and wipers.



CAUTION! The compatibility of lubricants must always be checked! This check should be done under both static and dynamic conditions

and within the operating environment. Some lubricants may have unexpected, negative reactions with the plastics, elastomers or non-ferrous metals within the products. It is possible to draw upon previous and practical experience or guidelines from the lubricant manufacturer. When in doubt, consult the lubricant manufacturer.

INITIAL LUBRICATION (DURING INSTALLATION)

PBC Linear Guides and Raceways are shipped with a preservative lubrication applied to the raceway. During installation, it is necessary to apply additional lubrication. Provided there are no application conflicts, PBC recommends high quality lithium soap grease as the initial lubricant. This grease should be applied to the entire raceway, not just the portion used during normal operation. Oil or grease may be used for re-lubrication.

Note: Coated/Plated rails, Commercial Rail, Hardened Crown Roller and Hevi-Rail rails are typically shipped without any preservative lubrication. See the Hevi-Rail section for more details: sandblast and lightly oiled option is available for Hevi-Rail.

PERIODIC LUBRICATION/MAINTENANCE

The lubrication interval is dependent on many operating and environmental conditions, such as load, stroke, velocity, acceleration, mounting position/orientation, type of lubrication used, temperature, humidity, UV exposure, etc. The actual lubrication interval should be determined by tests conducted under actual application conditions.

While the actual lubrication intervals are application specific and determined only through testing, the following guidelines can typically be used as a starting reference point under “normal” conditions:

- Re-lubrication every 1,000 km; 50,000 cycles or six months (whichever occurs first).



Technical

Lubrication

| REDI-RAIL | COMMERCIAL RAIL | HARDENED CROWN ROLLER | V-GUIDE | HEVI-RAIL |
|-----------|-----------------|-----------------------|---------|-----------|
|-----------|-----------------|-----------------------|---------|-----------|

OIL FILLED POLYMER LUBRICATOR

Some PBC Linear products offer a high quality polymer lubricator. PBC uses an advanced, oil filled porous polymer which has been tested to show better performance and longer life than similar wiper/lubricators made of oil or grease filled felt. In some applications, this special lubricator will last the life of the application without additional re-lubrication.

This lubricant within the polymer is NSF Registered for both H1 & H2 applications (Direct & Indirect contact with food). It can also be used for wash down & industrial applications. The lubrication within the polymer contains corrosion inhibitors, anti-oxidants & extreme pressure (E.P.) additives. The table below shows some specific properties for the lubricant.

PROPERTIES FOR LUBRICATION IN ADVANCED OIL-FILLED PLASTIC

| UPPER TEMP LIMIT | LOWER TEMP LIMIT | SPECIFIC GRAVITY | VISCOSITY AT 40°C CST | VISCOSITY AT 100°C CST |
|------------------|------------------|------------------|-----------------------|------------------------|
| 99° (210°F) | -40° (-40°F) | 0.86 | 150 | 16.5 |

USED LUBRICANTS

Used lubricants should be disposed of using environmentally-friendly methods. Most lubricant manufacturers have guidelines regarding their allowable storage, use and disposal. In addition, some countries have regulations regarding storage, use and disposal of lubricants for occupational safety and/or environmental protection. Furthermore, some companies may have adopted internationally accepted quality and standards policies (i.e. ISO14001) which will further regulate the use of lubricants within an application.

These guidelines and regulations must be followed. Care should be exercised as to not specify a lubricant which is forbidden.

LUBRICATION FAILURE

Contamination and Lack of Lubrication are the two primary causes of (ball based) linear guide failures. Lack of lubrication will cause Fretting Corrosion which can cause permanent system damage and eventually lead to system failure. As it applies to this product, Fretting Corrosion is a form of damage caused as a combination of corrosion and abrasive wear. Fretting Corrosion can typically be seen as a reddish discoloration on either mating raceway (track or roller). Fretting Corrosion can sometimes be confused with Rust. Both are signs that additional lubrication is necessary and the re-lubrication period must be decreased.

OPERATION IN AN UN-LUBRICATED STATE

While not recommended, it is possible to run most systems without lubrication; however, there will be significant reductions to maximum load, maximum speed and expected life. The table below shows that a typical un-lubricated system will have a significantly reduced maximum load and a reduced maximum speed when compared to a properly lubricated system.

TYPICAL REDUCTIONS FOR MAX LOAD & SPEED FOR UN-LUBRICATED SYSTEMS

| PRODUCT | | LUBRICATED | UN-LUBRICATED | REDUCTION |
|---------|---------------|------------|---------------|-----------|
| A | Max Load kg | 100 | 25 | 75% |
| | Max Speed m/s | 2 | 1.5 | 25% |

In addition to significant reductions in maximum load and speed, un-lubricated system will also experience an extreme reduction in expected life. The table below shows the expected life for both a lubricated and un-lubricated system for two different products with two different applied loads. The approximate reduction in lifetime has also been calculated.

TYPICAL LIFE REDUCTIONS FOR UN-LUBRICATED SYSTEMS

| PRODUCT | | LUBRICATED | UN-LUBRICATED | REDUCTION |
|---------|-------------------|------------|---------------|-----------|
| B | Applied Load 1 kg | 45.4 | 45.4 | – |
| | Life 1 m | 5,410,200 | 88,900 | ≈ 98% |
| | Applied Load 2 kg | 22.7 | 22.7 | – |
| | Life 2 m | 22,860,000 | 533,400 | ≈ 98% |
| C | Applied Load 3 kg | 45.4 | 45.4 | – |
| | Life 3 m | 50,800,000 | 863,600 | ≈ 98% |
| | Applied Load 4 kg | 90.7 | 90.7 | – |
| | Life 4 m | 8,382,000 | 152,400 | ≈ 98% |

Note: Actual performance will vary depending upon specific application conditions. PBC Linear has removed the actual product name from the examples listed above as the results may not be repeatable, depending upon specific application conditions. While these values are typical, specific reductions should be determined by tests conducted under actual application conditions.



General

Technical

REDI-RAIL**COMMERCIAL RAIL****HARDENED CROWN ROLLER****V-GUIDE****HEVI-RAIL**

OPERATING TEMPERATURE

The Cam Roller products shown in the catalog have a wide operating temperature limit. All of the products within this catalog can be used within the following range: -20°C to +80°C (-4°F – 176°F). For applications outside of this range, first refer to the specifications for individual products. If a wider range is still needed, please contact our Applications Engineering group using the contact information below.

The temperature range for these products is limited by the lubricant, engineered polymer wipers, and composite cover materials. In most cases, changing the lubricant or the engineered polymer will extend the operating temperature limit for the product.

VELOCITY & ACCELERATION

For maximum velocities, check the specific product specifications. The maximum velocities will range from 0.76 m/s up to 12 m/s. Higher speeds may be possible, but may not be sustainable. Please contact our applications engineering group for sustained speeds above 12 m/s (33 ft/s).

Unless otherwise noted, the maximum possible acceleration of all CRT products is approximately 5 G's (50 m/s², 160 ft/s²). Higher accelerations are possible, but may not be sustainable. Please contact our applications engineering group for sustained accelerations above 5 G's.

CONTACT INFORMATION

If you need to contact our Applications Engineering group, please use one of the following methods:
 Phone: 1.800.962.8979 (inside USA)
 Phone: +1.815.389.5600 (outside USA)
 Email: application.engineering@pbclinear.com



SAFETY GUIDELINES

Product Safety

PBC Linear's products are designed and manufactured to the most current level of technology and research. If the bearing (or linear guide) arrangement is designed correctly, handled correctly, installed correctly, and maintained correctly, then they do not give rise to any known or direct hazards. Misapplication, improper handling, improper installation, or improper maintenance may lead to premature product failure which may have unintended consequences.

Read & Follow Instructions

This publication describes standard products. Since these are used in numerous applications, PBC Linear cannot make a judgment as to whether any malfunctions will cause harm to persons or property. It is always, and fundamentally, the responsibility of the designer and user to ensure that all specifications are observed, and that all necessary safety information is communicated to the end user. This applies in particular to applications in which product failure and/or malfunction may constitute a hazard to human beings.

Symbols

This publication uses several hazard, warning and notification symbols which are defined in accordance to ANSI Z535.6-2006.

NOTIFICATIONS

© PBC Linear 2014. All rights reserved. No part of this publication may be reproduced, stored in a retrieval system, or transmitted in any form or by any means without the prior written permission of PBC Linear.

The data and specifications in this publication have been carefully compiled and are believed to be accurate and correct. However, it is the responsibility of the user to determine and ensure the suitability of PBC Linear products for a specific application. PBC Linear makes no warranty, expressed or implied, regarding the non-infringement, merchantability, or fitness for a particular purpose of the products. No liability is assumed with respect to the use or misuse of the information contained herein. PBC Linear's only obligation will be to repair or replace without charge, any defective components if returned promptly. No liability is assumed beyond such replacement. The appearance, specifications, and other information are subject to change without notice to improve reliability, function, performance, etc.

PBC Linear shall not be responsible for special, indirect or consequential damages, loss of profits or commercial loss in any way connected with the products, whether such claim is based on contract, warranty, negligence or strict liability.

Trademarks & Copyrights: Product and System names are service marks, trademarks, or registered trademarks of their respective companies. Their use within this publication is without intent to infringe. This notice is accurate as of the date of publication. Visit www.pbclinear.com for the most current version of this notice as well as for the most current product information.

Worldwide Headquarters
PBC Linear
A Pacific Bearing Co.

6402 E. Rockton Road
Roscoe, IL 61073 USA
Toll-Free: 1.800.962.8979
Fax: 1.815.389.5790
sales@pbclinear.com
www.pbclinear.com



European Branch
PBC Lineartechnik GmbH
A Pacific Bearing Co.

Röntgenstr. 8
40699 Erkrath, Germany
Telefon: 0049 2104 957440 0
Fax: 0049 2104 957440 9
info@pbclinear.de
www.pbclinear.de



PBC Linear has a global network a distributors with thousands of locations worldwide.
Visit www.pbclinear.com to find a distributor near you.

